

WARRANTY

Tadano Ltd. (herein referred to as TDN) warrants that each new Product manufactured by TDN shall be free from defects in material or workmanship under normal use and maintenance for a period of twelve (12) months or 1,500 hours, whichever occurs first, from the date of initial sale, lease or rental.

Within the United States, the distributor designated by TDN, shall repair and replace free of charge, including related labor, any such defective parts.

This warranty does not apply in the following cases, even when they occur during the warranty period:

1. Damage or defects caused by accident, misuse, negligence or natural calamity.
2. Damage or defects caused by using other than TDN genuine parts.
3. Damage or defects ascribed to repair work or modification, etc., being carried out at workshops other than those designated by TDN.
4. Damage or defects arising from the use of a product beyond the operating limitations specified by TDN.
5. Damage or defects caused by failure to operate, service or maintain products in accordance with the operation and maintenance manual or other instruction of TDN.
6. Loss of use, loss of time, inconvenience and other consequential damages such as expenses for fuel, telephone, travel, lodging, transportation, loss or damages to personal property or loss of revenues.
7. Slight defects that generally do not affect the integrity or reliability of product.
8. Corrosion or discoloration of plated surfaces caused by aging.
9. Consumable articles such as oil, fan belts, packings, gaskets, fuses, brake linings, fuel filters and other similar parts.

The present warranty is in lieu of any other warranties, expressed or implied, including any warranty of merchantability or fitness for a particular purpose.

TADANO LTD.

Introduction

This manual describes how to properly use the machine of the specification No. shown below.

This manual also describes inspection and maintenance, and measures to be taken in an emergency. Be sure to read this manual before use.

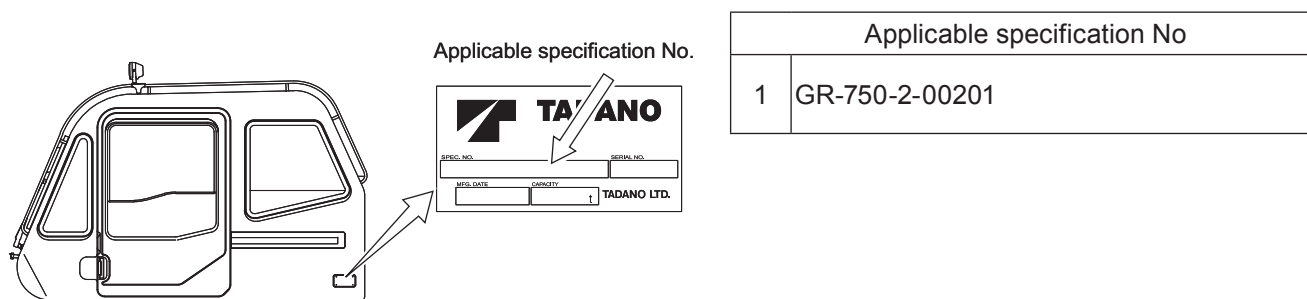

K03077-00E

This manual is divided into "Traveling", "Operation", "Inspection and Maintenance", "Emergency Operation" and "Information and Data".

For operation, inspection and maintenance of the item below, read the separately attached manuals.

- Engine

Keep this manual in the cab so that it can be consulted at any time.

If this manual is lost or damaged, immediately place an order from your nearest TADANO distributor or dealer.

When transferring this machine, also transfer this manual together with the machine.

If you have any questions regarding this machine, contact your nearest TADANO distributor or dealer.

Warranty

Check details of the warranty policy.

The engine in this machine is warranted as specified in the warranty policy issued by the engine manufacturer.

Do not handle this machine in any way other than described in this manual. Note that the warranty of TADANO or the engine manufacturer shall not cover any failure or accident caused by improper handling.

Do not modify this machine.

Failure or accidents caused by modification by the customer shall not be covered by the warranty.

In Event of Failure

If a failure occurs in this machine, contact your nearest TADANO distributor or dealer and inform them of the items below.

(1) Serial No.

(2) Details of the failure

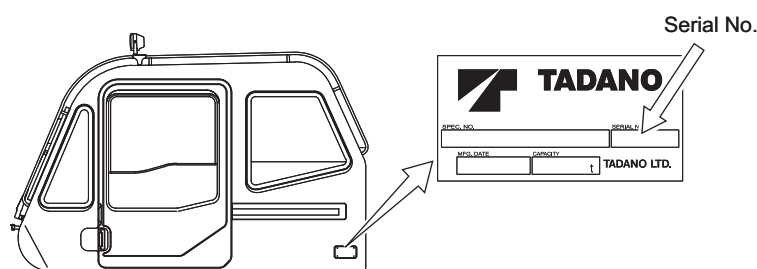

K03078-00E

Using Crane Out of the US (Including Satellite Communication Terminal)

This is a US-specification machine, conforming to the laws and standards of the US. If you use this machine out of the US, you must observe the laws and standards of the country where the machine is used. Do not use this machine until it is confirmed that the machine conforms to the laws and standards of the country

For the machines equipped with the satellite communication terminal, termination of communication contracts and removal of the satellite communication terminal are required before you ship the machine out of the US.

Please contact a TADANO branch or sales office beforehand.

For Safety

Read all the precautions for safety and understand them before operation, inspection, and maintenance.

Many accidents during operation, inspection, and maintenance are caused by ignoring the basic safety rules and precautions.

Be aware that disregarding even one safety precaution can result in a serious accident involving persons and properties around the machine.

In order to prevent accidents, it is important to predict danger.

The responsible manager and operator shall recognize the potential dangers specific to the operation, and take proper measures according to the degree of danger.

Safety is described in "Safety Precautions", "Precautions for Inspection and Maintenance", and also in each corresponding section.

It is also described on the warning labels (nameplates) on the machine.

This manual and warning labels (nameplates) use terms of "DANGER", "WARNING", "CAUTION", and "NOTICE" to call attention in order to emphasize that they are important for safety and procedures. Meanings of these terms are as follows.

⚠ DANGER

DANGER indicates a hazardous situation which, if not avoided, will result in death or serious injury.

⚠ WARNING

WARNING indicates a hazardous situation which, if not avoided, could result in death or serious injury.

⚠ CAUTION

CAUTION indicates a hazardous situation which, if not avoided, could result in minor or moderate injury.

NOTICE

NOTICE indicates an important measure or condition for handling, and indicates that, if not observed, there is a risk of damaging the equipment or device, or degrading performance and function of the machine.

 Reference

Reference indicates a description of useful information or things desirable to be known.



Indicates prohibited actions in the illustrations.

Any operation shall comply with the descriptions in this manual.

In actual operation, risks associated with the machine vary greatly depending on the conditions such as operation method, environment at the site, and weather. Therefore, observe the safety precautions described in this manual and on the warning labels, and also pay sufficient attention to anticipate potential risks regarding operation to prevent accidents and damage to the machine.

Your most important duty is to secure safety for yourself, co-workers, and persons around the machine.

Contents

WARRANTY	3	■ TRAVELING	63
Introduction	5	Before Traveling	65
Warranty	5	Check of Traveling Configuration	65
Using Crane Out of the US (Including Satellite Communication Terminal)	6	Status of the Traveling Controls	65
For Safety	6	Inspection before Traveling	65
Contents	8	Entering the Cab	66
Name of Each Part	12	Opening/Closing the Door	66
Contents	13	Opening/Closing the Window	68
Traveling System	13	Adjustment of the Seat	69
Crane Control System	17	Adjustment of the Steering Wheel	70
Other Controls	21	Adjustment of the Mirrors	70
Safety Precaution	23	Fastening/Unfastening of the Seat Belt	71
Precautions before Starting Engine	23	Adjustment of the Control Lever Stand	72
Precautions for Traveling on Roads	28	Sunshade	72
Precautions during Operation	33	Reading the Instrument Panel	73
Warning Labels	49	Meters and Gauges	73
Label Location and Content of Warnings	50	DPF (Diesel Particulate Filter) Indicator	77
		Warning Lamp	79
		Starting and Stopping the Engine	82
		How to Start the Engine	83
		How to Stop the Engine	84
		DPF regeneration	85
		Transmission Operation	87
		Shift Lever Operation	88
		Brake Operation	90
		Foot Brake Operation	92
		Parking Brake Operation	93
		Exhaust Brake Operation	93
		Steering Operation	94
		Selecting the Steering Mode	96
		Drive Mode Selection	100
		Drive Mode Selection	101
		Lighting Switch and Other Switches	102
		Lighting Switch	102
		Turn Signal Lever	103
		Hazard Lamp Switch	104
		Horn Switch	104
		Wiper	105

Accessories in Cab	106	■ OPERATION	119
Fuel Consumption Monitor	107	Terminology	121
Air Conditioner	110	Before Crane Operation	123
Cab Lamp.....	115	Pre-operational Inspection	123
Cigarette Lighter.....	115	Preparing for Crane Operation.....	123
Outside Cab Accessory	116	How to Read Performance Data Plates	125
Radiator Cover	116	Working Range Chart.....	125
Handling Tires	117	Rated Lifting Capacity Table	127
Tire Air Pressure	117	Reduction of Rated Lifting Capacity.....	135
Restriction of Continuous Traveling.....	117	Load Moment Indicator (AML)	137
Operation in Cold Season	118	How to Read the Indication	140
Winterization.....	118	Selecting the Display.....	144
		Crane Status Indicator.....	145
		Registration of Operating State and Load	
		Moment Indicator (AML) Function Check.....	147
		Alarm and Recovery Operation.....	157
		Other Functions.....	162
		Action Against Load Moment Indicator System	
		Errors.....	183
		Other Safety Devices	184
		Anti-Twoblock Device	184
		Load Moment Indicator External Warning	
		Lamps.....	186
		Load Moment Indicator External Warning	
		Lamps (option)	186
		Anemometer (Option)	
		(For Serial No. 548535 or later)	187
		PTO	190
		PTO "ON" Operation	190
		PTO "OFF" Operation	191
		Outriggers	192
		Outrigger Set-up.....	195
		Extending the Outriggers	197
		Horizontal Set-up	201
		Stowing the Outriggers.....	203
		Hoisting	206
		Hoisting Up/Down	206
		Drum Indicator (Visual Type)	208
		Drum Indicator (Vibration Type) (Option)	208
		Boom Telescoping Control	209

Elevating the Boom	215	■ INSPECTION AND MAINTENANCE ..	307
Boom Raising/Lowering Operation	215	Precautions for Inspection and Maintenance ..	309
Elevation Slow Stop Function	216	Precautions for Inspection and Maintenance ..	309
Swinging the Boom	217	Inspection and Maintenance	317
Swinging the Boom	218	About Inspection and Maintenance	317
Swing Free/Lock Selector Switch	220	Under Severe Use (Severe Condition)	318
Automatic Swing Stop Function	220	Conditions of Severe Use	318
On-rubber Operation	221	Periodic Replacement Part	319
On-rubber Stationary Operation	222	Inspection and Maintenance Interval (Carrier) ..	322
On-rubber Creep Operation	223	Inspection and Maintenance Interval (Crane) ..	328
Taking Out and Stowing the Hook Block	225	Inspection before Traveling	332
Taking Out the Main Hook Block	225	Abnormal Items Detected On the Previous Day	
Stowing the Main Hook Block	226	or Operation	333
Reeving the Wire Ropes	227	Inspection around Carrier	334
Standard Number of Parts of Line	227	Inspection of the Engine Room	342
Reeving Procedure	230	Inspection at Driver's Seat	345
Single Top	235	Pre-operational Inspection	351
Mounting Single Top	236	Hydraulic System	353
Stowing Single Top	240	Control System	354
Jib	244	Outrigger System	355
Registration of Jib State	246	Swing System	357
Jib Lift	247	Boom, Jib System	358
Outline of Jib Installation	248	Lifting Device	360
Mounting of Base Jib	249	Safety Devices	363
Mounting of Base Jib + Top Jib	259	Inspection of Crane Structure	365
Changing Jib Offset Angle	270	Greasing	367
Outline of Jib Stowing	273	Maintenance Table	368
Stowing of Base Jib	274	Greasing Chart	369
Stowing of Base Jib + Top Jib	282	Gear Oil	372
Dismounting Jib	288	Maintenance Table	372
Mounting Jib	290	Winch Speed Reducer	
Mounting and Dismounting Counterweight	292	(Main/Auxiliary Winch)	373
Dismounting Counterweight	293	Swing Speed Reducer	374
Mounting Counterweights	298	Axle (Carrier)	376
Accessories in Cab	301	Axle (Planetary Gear)	377
Flood Lamp Switch	302	Engine	379
Roof Washer Switch	302	Maintenance Table	379
Roof Wiper Switch	302	Radiator Fin	379
ECO Mode Switch	303	Engine Cooling System	380
Searchlight (Option)	304	Maintenance Table	380
Accessories Outside of Cab	306	Coolant Filter	381
Winch Drum Monitoring Mirror	306		

Torque Converter System	382	EMERGENCY OPERATIONS	421
Maintenance Table	382	Action against Emergency	423
Transmission	382	If Failure Occurs during Traveling on a Road ..	423
Line Filter	385	If Stalled at a Railroad Crossing	423
Fuel System	386	To Interrupt DPF Regeneration	424
Maintenance Table	386	If Transmission Cannot Be Operated	425
Draining Water from Water Separator	387	If Engine Speed Does Not Increase	428
Brake System	388	If the Engine Does Not Stop	428
Maintenance Table	388	If Overheated	429
Brake Fluid Reservoir	388	When Towed	
Disk Brake Pad	389	(Vehicle with Emergency Steering Pump)	430
Air Dryer	390	If the Boom Cannot Be Telescoped	433
Parking Brake Pad	391	If the Outrigger Extension Detection Device	
Tire, Wheel	393	Fails	435
Maintenance Table	393	If Getting In/Out of Cab Door is Not Possible	
Tire	393	(Optional)	437
Wheel Nut	395	INFORMATION AND DATA	439
Hydraulic system	396	Conversion Tables	441
Maintenance Table	397	Hand Signals	444
Hydraulic Oil Tank	398	Major Specifications	447
Return Filter (Front of Hydraulic Tank)	400	Crane Specifications	447
Line Filter (Steering, Swing Pump Circuit)	400	Carrier Specifications	448
Swing System	402	Overall Dimensions	449
Maintenance Table	402	Mass	450
Swing Bearing Mounting Bolt	402	Wire Rope	450
Electrical System	405	Other	450
Maintenance Table	405	Oils and Greases	451
Replacing Fuses	405	Oils and Greases Table	451
Air Conditioner System	408	Recommended Oils and Greases	452
Maintenance Table	408	Service Data	455
Condenser	408	Service Data	455
Refrigerant Level	408		
Refrigerant Piping Connection	409		
Inside Air Filter	409		
Outside Air Filter	409		
V-belt	410		
Periodic Replacement Part	410		
Wire Rope	411		
Replacing Wire Ropes	411		
Handling Wire Ropes	418		

Name of Each Part

""Front", "rear", "left", and "right" are the directions seen from the operator's seat when the boom is directed toward the front of the frame. These directions are fixed regardless of the swing direction of the superstructure.

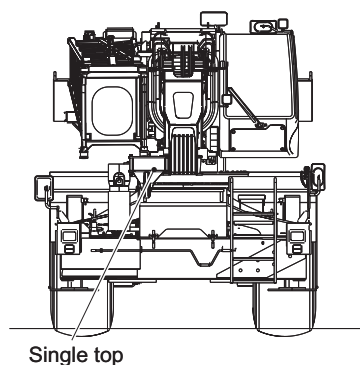
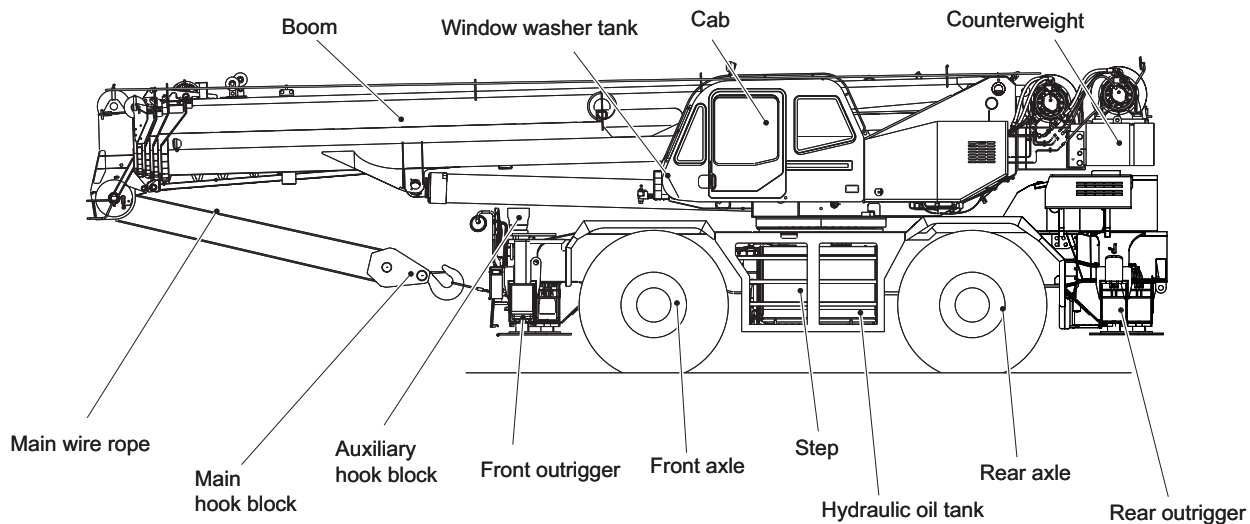
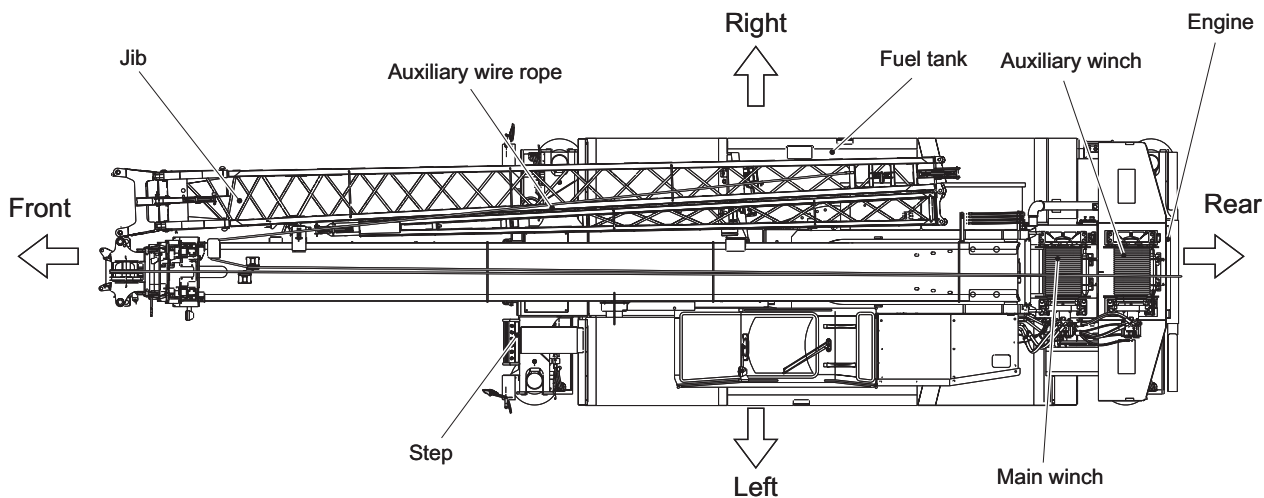

K07001-00E

GR-750XL-2_OM2(U)-17E

Contents

Traveling System

Inside the Cab

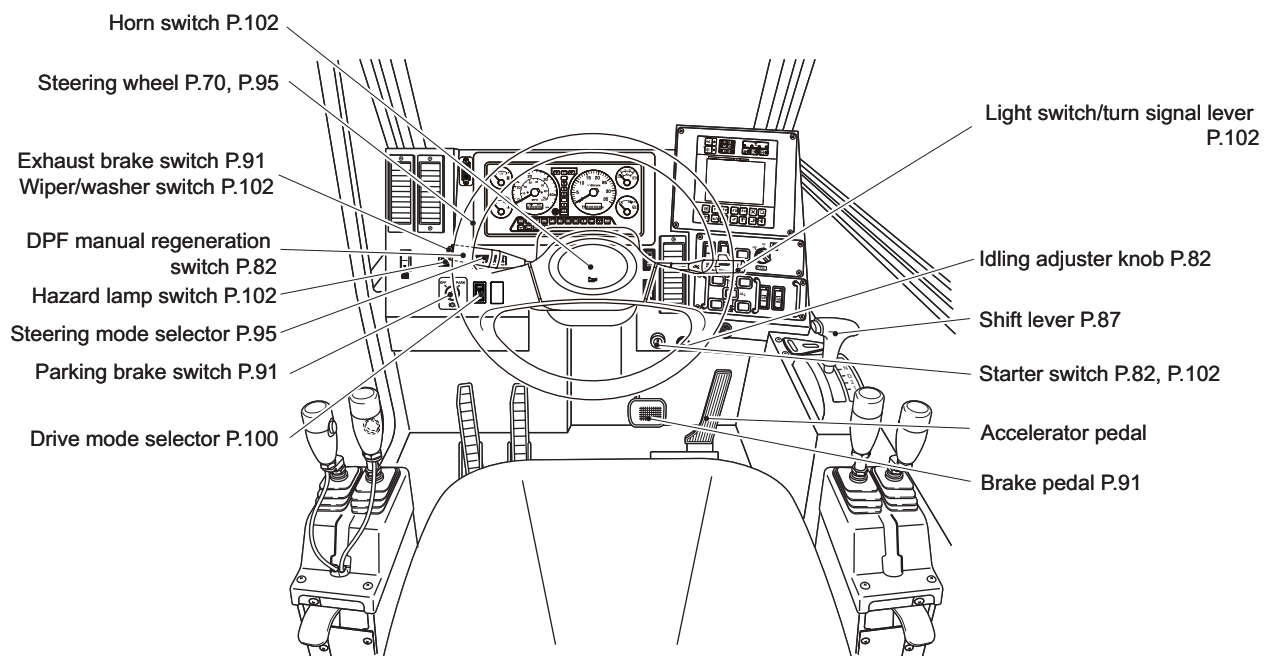

K07002-00E

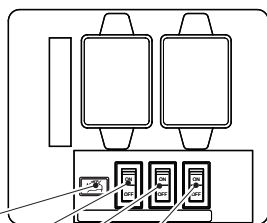
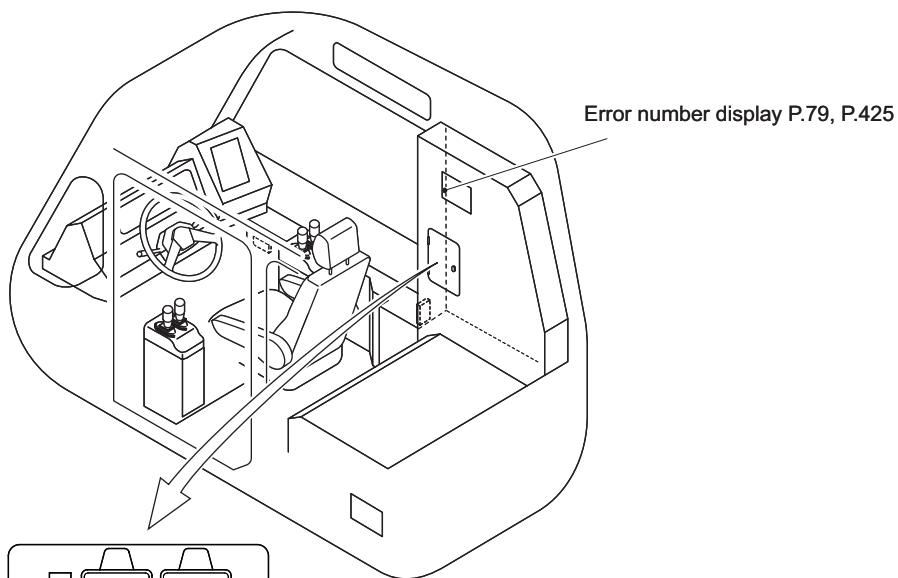

Emergency engine stop switch P.425

Emergency accelerator switch P.425

Emergency transmission switch P.425

DPF regeneration disabled switch P.73, P.424

K07003-00E

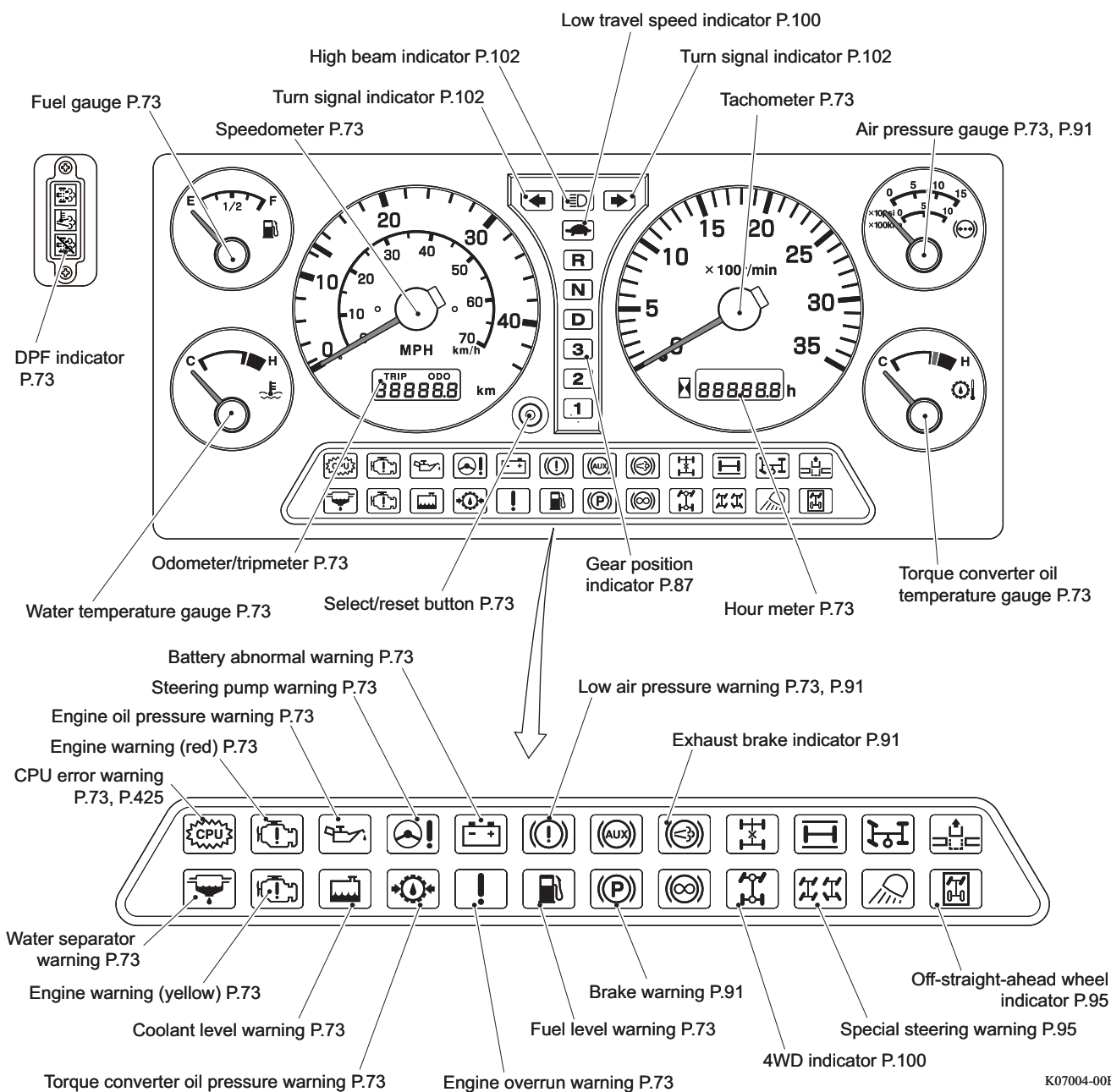

K07004-00E

Outside the Cab

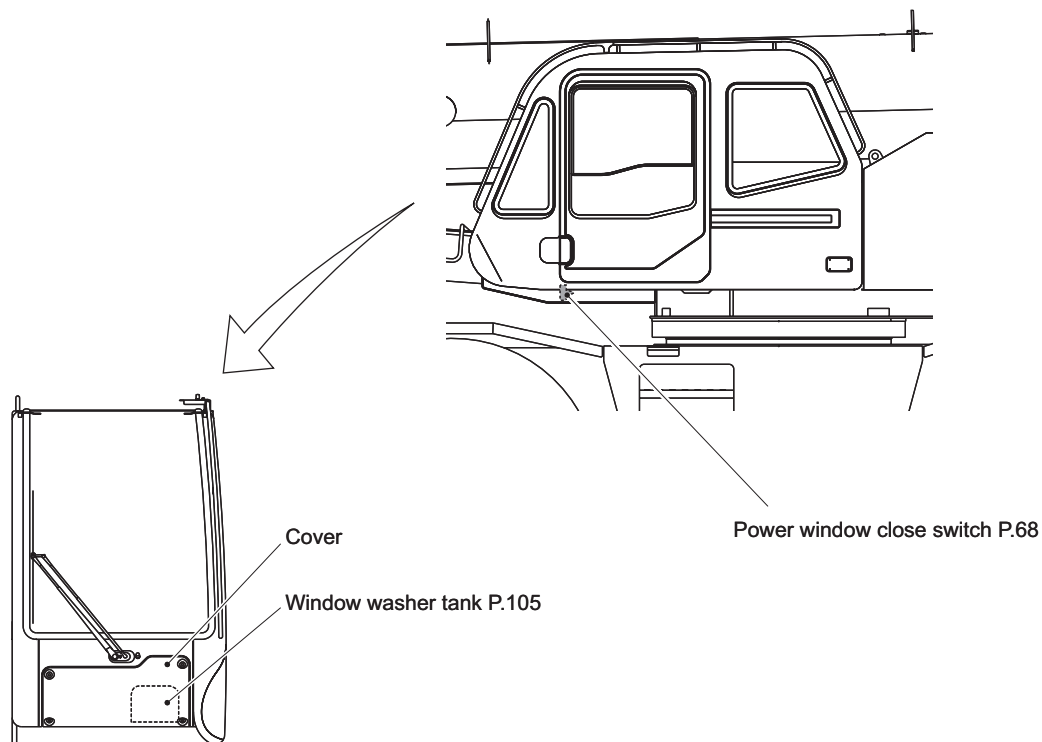

K07005-00E

Crane Control System

Inside the Cab

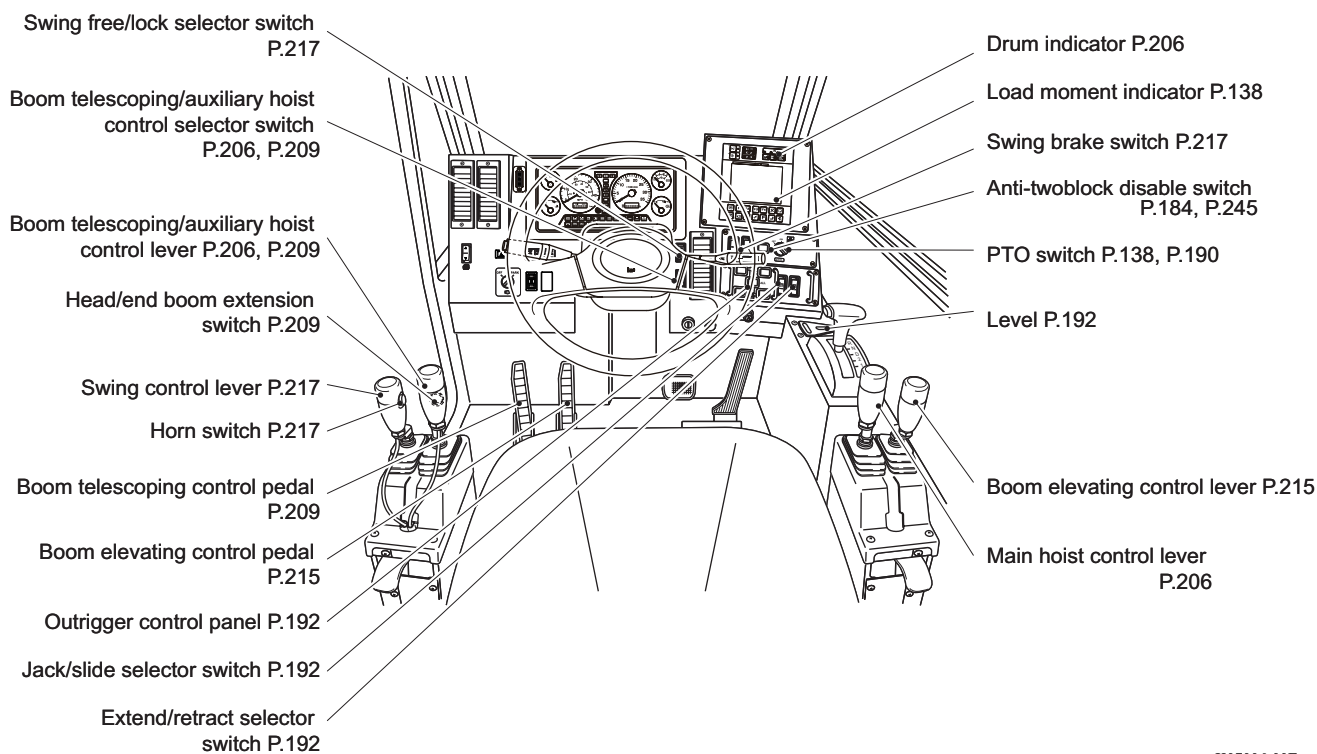

K07006-00E

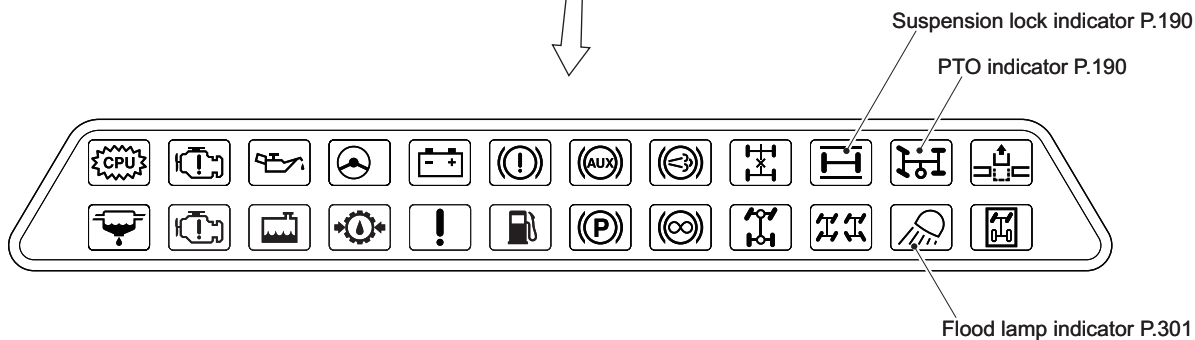
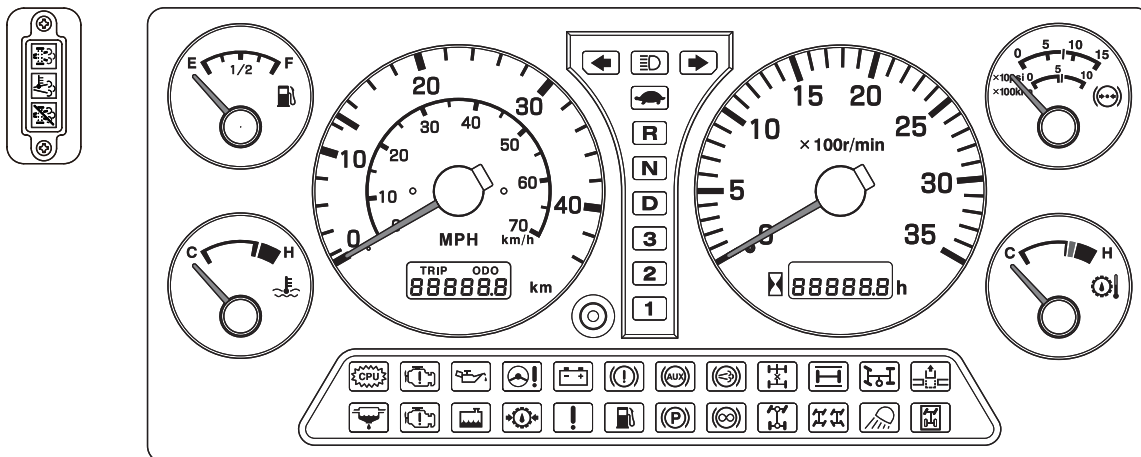

K07007-00E

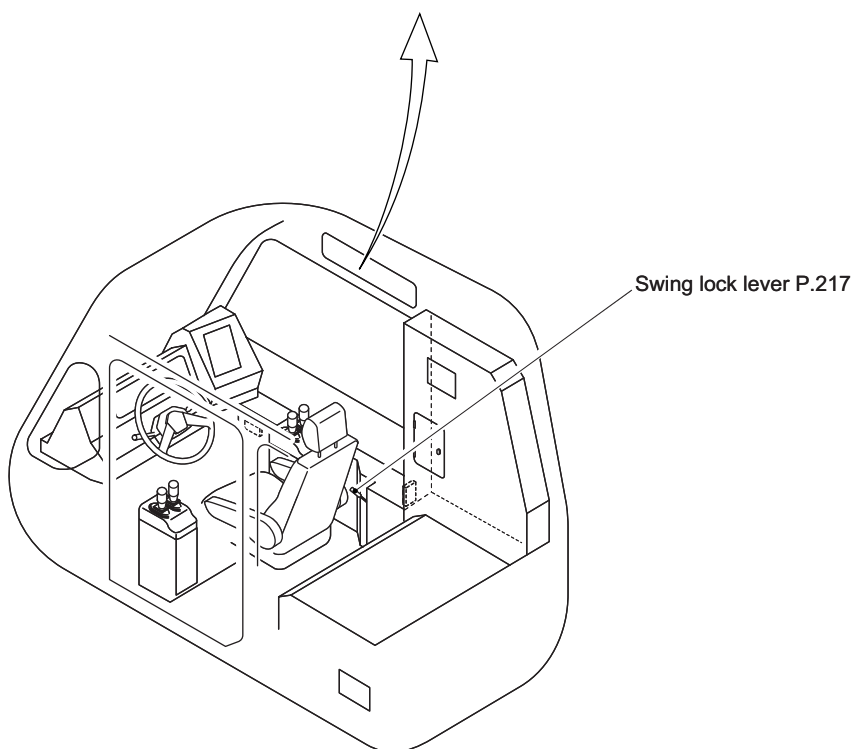
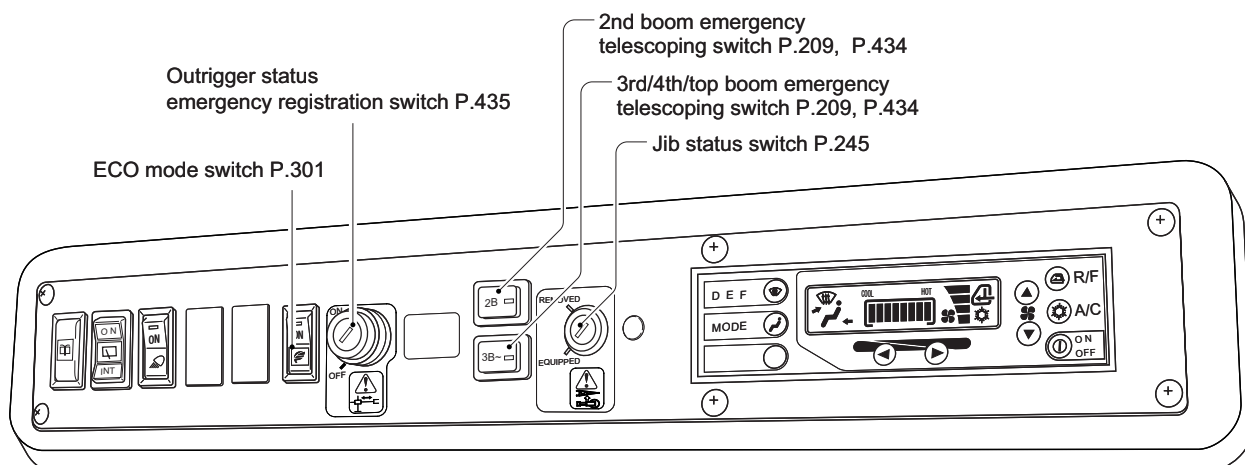

K07008-00E

Outside the Cab

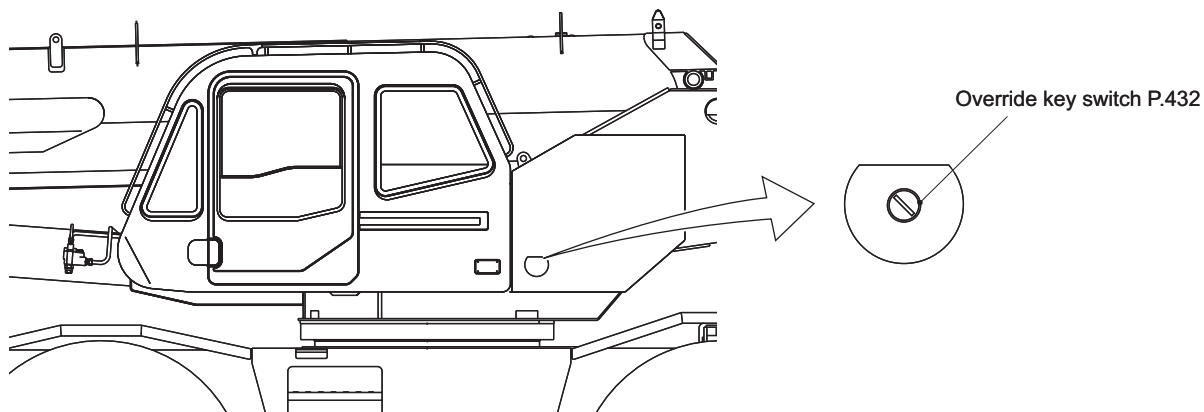

K07009-00E

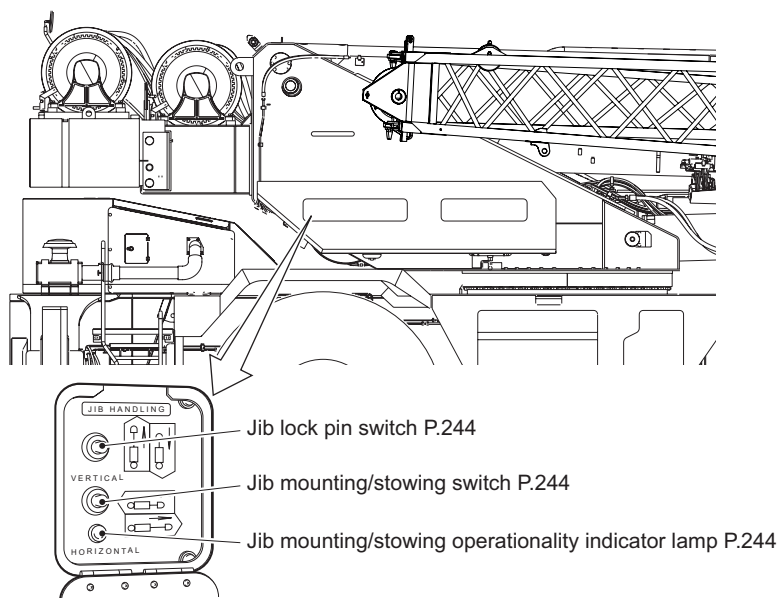

K07010-00E

Other Controls

Inside the Cab

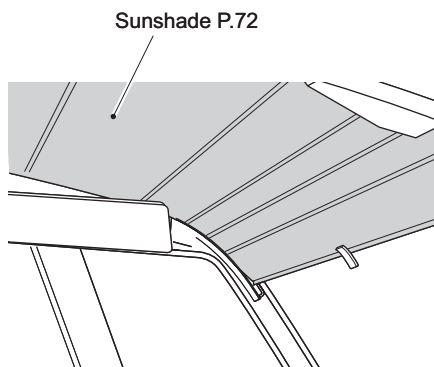
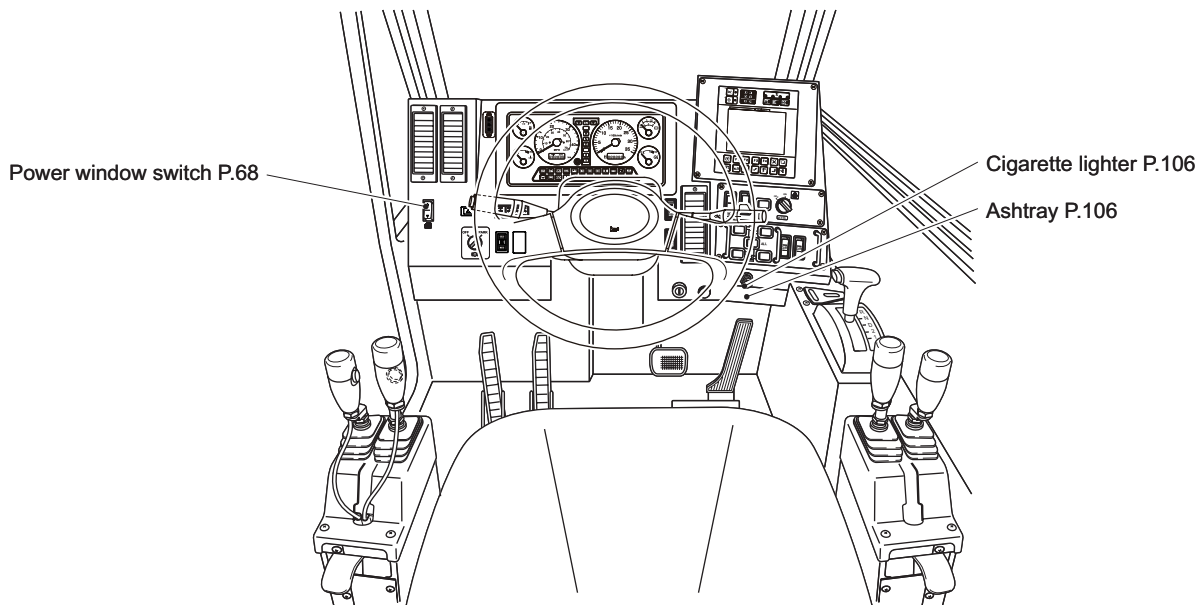

K07011-00E

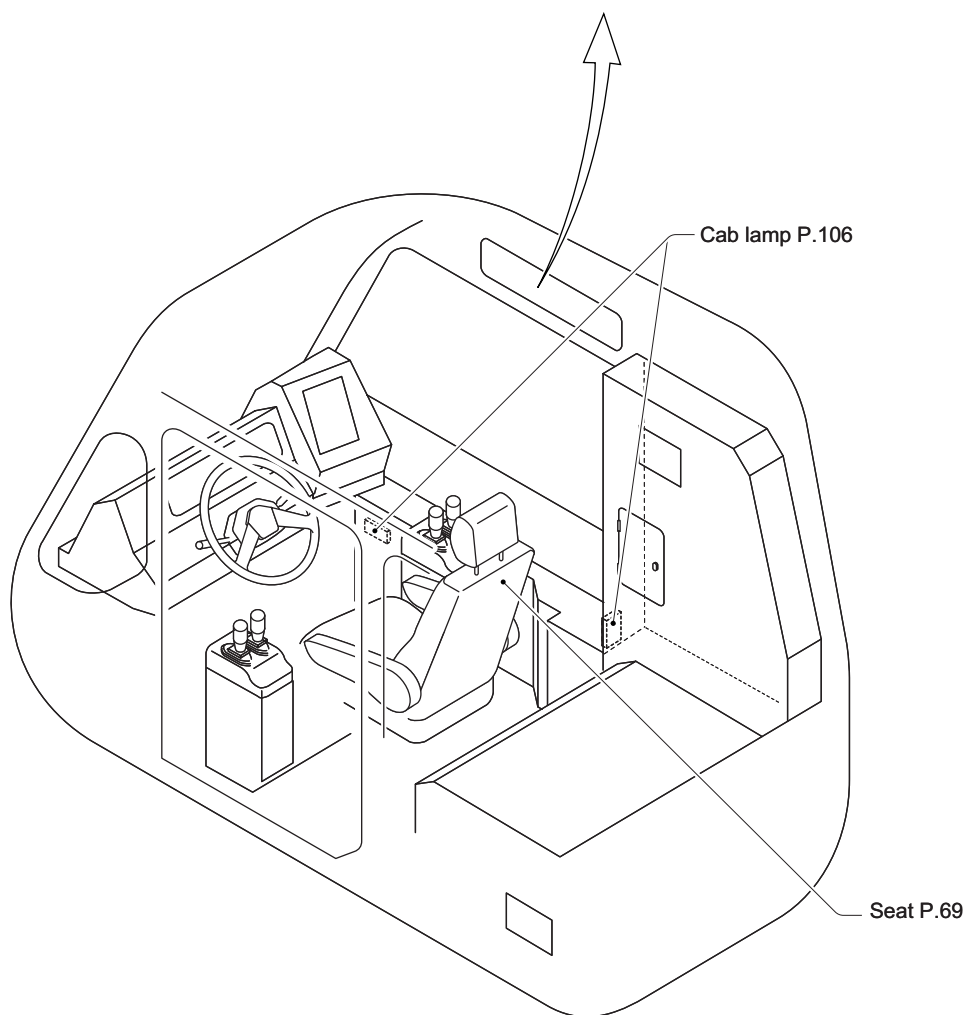
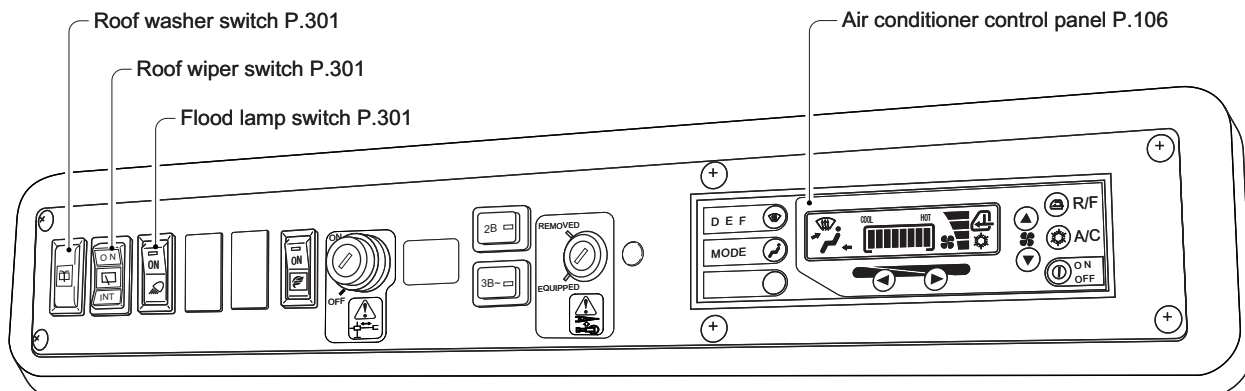

K07012-00E

Safety Precaution

⚠ WARNING

"Safety Precaution" describes the precautions necessary to prevent accidents during machine use. For specific precautions, refer to the corresponding paragraphs in the main text of this manual (white pages).

Illustrations supplement the precautions and show you where the important points are. Note that the shapes, etc. in the illustration can be different from the actual machines.

Precautions before Starting Engine.....	23
Precautions for Traveling on Roads.....	28
Precautions during Operation	33

Precautions before Starting Engine

• Read This Manual

Incorrect machine operation, inspection, and maintenance can damage the machine and cause an injury or death.

Read this manual carefully to understand fully how to operate, inspect, and maintain the machine. Do not start work until you understand this manual.

Keep this manual in the cab so that you can consult it at any time.



G05001-00E

• Follow Instructions and Warnings

This manual and warning labels (nameplates) give instructions and warnings necessary for safe operation. Read and understand them first. If you neglect the instructions and warnings, an injury or death can occur.



G05002-00E

• Care of Warning Labels (Nameplates)

The warning labels (nameplates) attached on the machine give important precautions necessary when you use the machine. Always keep the warning labels (nameplates) clean and readable.

If any warning label is lost or damaged, order a new one from your nearest TADANO distributor or dealer and attach it.



G05003-00E

• Prepare for Emergency

Make sure you know where the first-aid kit and fire extinguishers are kept, and how to use them against possible accidents or fire. In addition, prepare a list of emergency contact persons and communication methods beforehand.

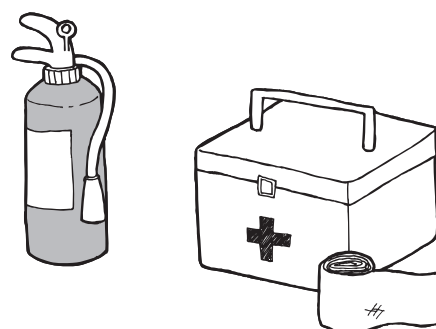

G05004-000

• Wear Proper Clothing

If you do not wear your clothes properly, they can catch levers or protrusions of the machine, and an accident can occur. Always wear your clothes properly.



G05005-000

• Wear Protective Equipment

Wear protective equipment such as a hard hat, safety shoes, and protective gloves to ensure safety while you work.

Wear a safety belt while you work at an elevated area (height of 6.5 ft {2 m} or more).

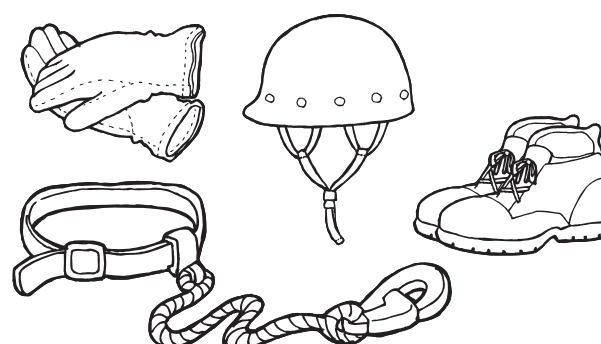

G05006-000

• Do Not Operate the Crane When You are Tired or Under Influence of Alcohol

You cannot focus your attention if you are tired, short of sleep, or under influence of medication or alcohol. Do not operate the machine in such cases. It affects your judgment required for operation.

• Keep Floors and Shoe Soles Clean

Oil and Mud on the shoe soles, pedals, steps or passage floors make your foot slip. This can cause a falling accident or an operation error.

Completely wipe off oil and mud from shoe soles and floors before operation, and always keep them clean.

The operators and other workers should wear slip-proof shoes.

Do not place parts or tools in the footwell of the operator's seat or on the passages, which will obstruct safe operations.



K01431-00E

• Get On/Off the Machine Safely

Do not jump on or off the machine.

Do not get on or off the machine while carrying something in your hand.

Only after the machine has stopped completely, get on and off the machine with your front body facing the machine. Always hold your body at 3 or more points by using handrails and steps.

Do not use the steering wheel or control lever to support your body.

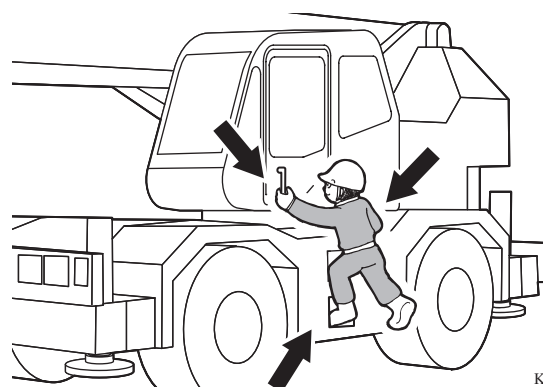

K01432-000

• Keep Visibility in Good Condition

If window glasses, lights, or mirrors are dirty, poor visibility hinders safe operation.

Always keep the window glasses and lights clean to ensure a good visibility.

Adjust the mirrors so that you can have a best view from the driver's seat.

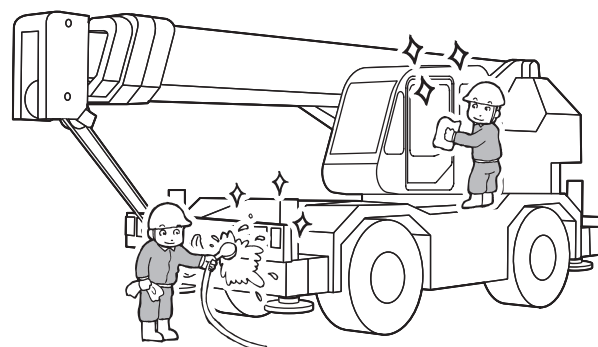

K01482-000

• Never Operate the Machine during Inspection and Maintenance

If you operate the machine during inspection and maintenance, an accident or a damage to the machine can occur.

While a warning tag is hung on a door or control lever, do not operate the machine until the warning tag is removed by the maintenance technician.

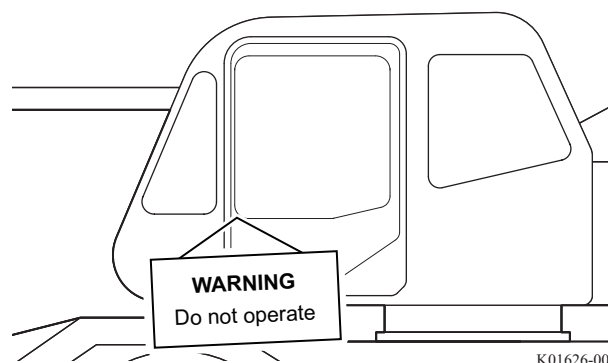

K01626-00E

• Hold a Staff Meeting Before Work

An accident can occur if pre-work staff meetings are not held or are inadequate. Before the start of the work, make arrangements in detail with the workers such as the supervisor, rigging workers, and signal persons about the points listed below. Make sure that the decisions are obeyed.

- Based on the rated lifting capacity table, the mass of the load to be lifted, the lifting height, the place for loading and unloading, the place for crane set-up, work procedures, rigging method, etc.
- Check of ground conditions where the crane is set-up, and presence of buried objects such as water/gas pipes
- Methods of preventing overturning, such as extension of outriggers and use of steel plates on the ground
- Selection of rigging workers and signal persons, and agreement about the signaling method
- Setting of off-limits zone, fencing, and installing ropes
- Check of the work positions for related workers
- Check of emergency communication methods, contact addresses, and safety and health organizations in charge



G05012-000

• Check Control Lever Positions before Starting the Engine

If control lever positions are wrong, the machine can start moving when the engine is started. This is very dangerous. Check that all the control levers are at the correct positions before starting the engine.

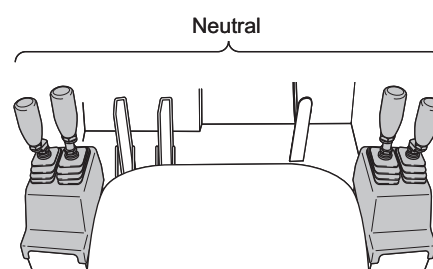

K02120-00E

• Check Safety around the Machine before Starting the Engine

If you start the engine without checking safety around the machine, it can cause a damage to the machine, or an injury or death.

Before you start the engine, make sure that there are no persons or obstacles under or around the machine.

Before you start the engine, sound the horn to alert people around the machine.

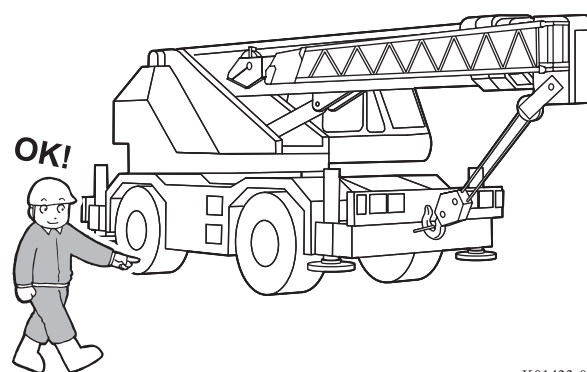

K01433-000

• Keep Surroundings of the Engine Clean

Flammable objects such as dead leaves, wastepaper, and oil stains near the engine can cause a fire.

Remove them before operation.

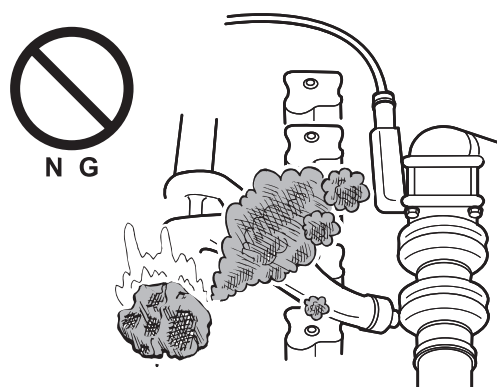

G05015-00E

• Be Careful when Refueling

Fuel is highly flammable and dangerous. Other oil and grease are also flammable and dangerous. When you handle them, pay sufficient attention.

When you refuel the machine, observe the precautions below.

- Stop the engine.
- Refuel the machine in a well-ventilated open place.
- Keep open fire such as a lit cigarette away.

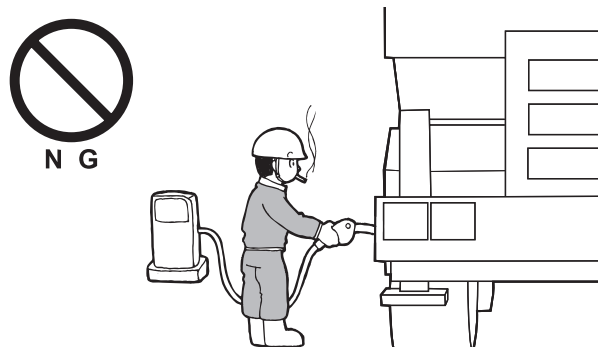

G05017-00E

Precautions for Traveling on Roads

• Inspection before Traveling

If the machine has any defects, it is dangerous to drive the machine without repairing it. Inspect the machine according to the chapter "Inspection before Traveling" and "Inspection before Starting Work" in this manual.

If you find any abnormalities, report them to the person in charge and have the machine repaired before traveling.

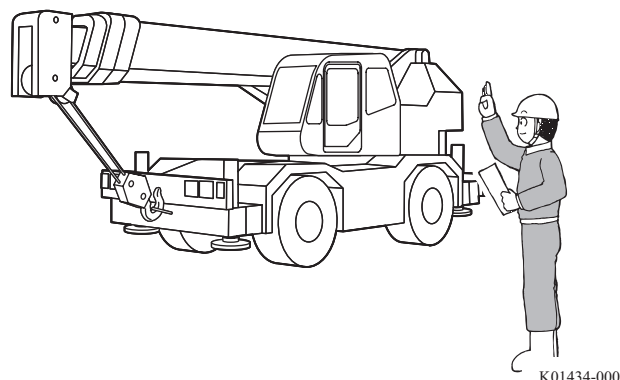

• Keep Visibility in Good Condition

If window glasses, lights, or mirrors are dirty, poor visibility hinders safe operation. Always keep the window glasses and lights clean to ensure a good visibility.

Adjust the mirrors so that you can have a best view from the driver's seat.

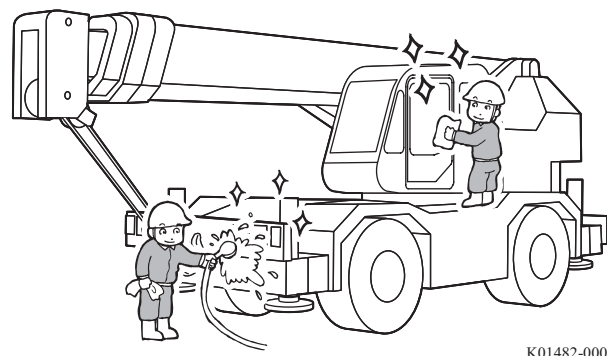

• Set the Machine in Traveling Posture Before Traveling on Roads

It is dangerous if the hook block or boom sways, or an outrigger beam extends while traveling.

Traveling with a jib mounted causes a larger protrusion to the front and creates hazards. Stow the hook block, boom, and jib, to the specified positions, and secure the outrigger beams with the lock pins.

Set the machine into the traveling posture following the instructions in the manual before traveling.

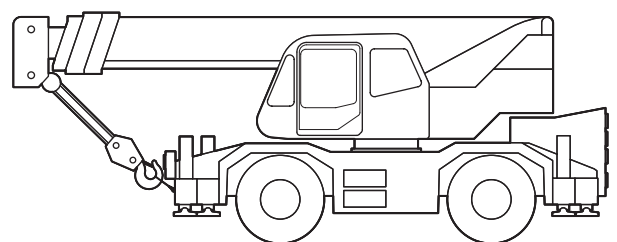

• Travel on Roads in Two-Wheel Steering Mode

Do not travel on roads in special steering mode. It is dangerous for other road users. Travel on roads only in the two-wheel steering mode.

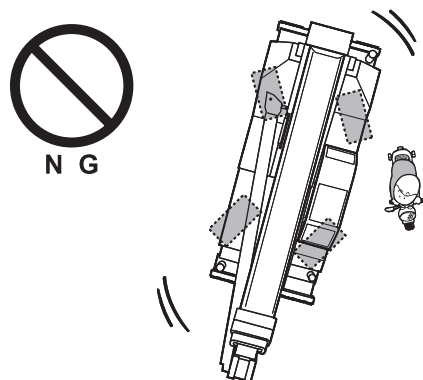

- **Do Not Travel with Cargo Loaded on the Machine**

Traveling with cargoes loaded other than standard equipment can cause accidents such as a falling of the cargo. To carry a cargo, use a dedicated machine such as a truck.

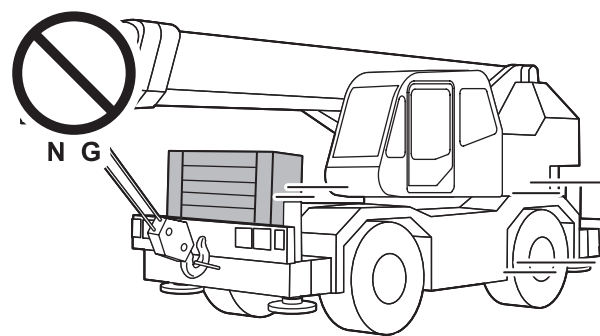

K01437-00E

- **Observe Seating Capacity**

Traveling with more passengers than the seating capacity is a violation of applicable laws and regulations. Also, it can cause an accident.

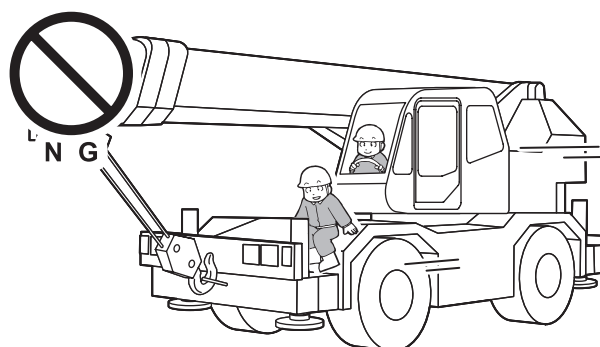

K01438-00E

- **Wear Seat Belts**

Wear the seat belt while traveling to ensure safety. Wear the belt securely without twisting it.



G05023-000

- **Check Safety around the Machine before Starting**

Make sure that there are no persons or obstacles around the machine before starting.

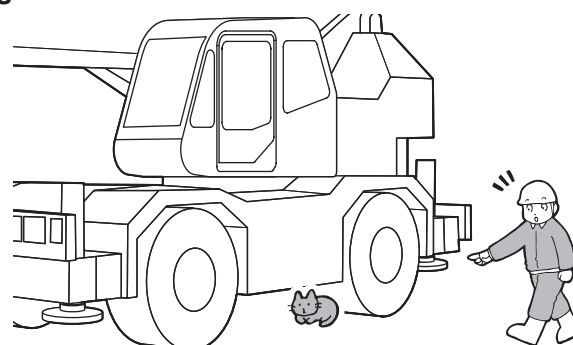

K01439-000

• Pay Attention to Safe Driving

Keep a sufficient distance from the preceding vehicles, maintain a moderate speed, and apply brakes early.

Do not drive in an aggressive manner such as overspeeding, sudden starting, sudden braking or steering.

• Post a Guide Person at a Place with Poor Visibility

To prevent collisions, post a guide person when traveling at a tight area or corner with poor visibility, and when you reverse the machine.

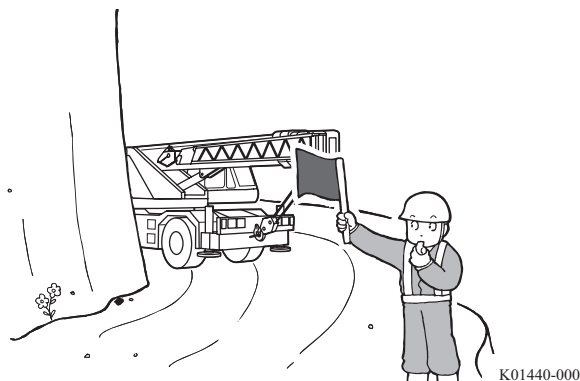

K01440-000

• Be Careful of Road Surface Conditions

A road with poor surface conditions can cause slipping or loss of steering control, resulting in an accident.

If you drive the machine on a snow-covered or frozen road, rough ground or slope, pay extra care to ensure safety.

Check the road surface conditions before traveling, and attach tire chains as necessary.

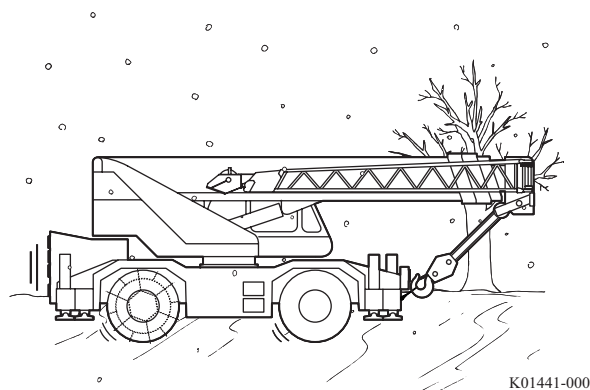

K01441-000

• Be Careful of Overhead Objects

Accidents can occur depending on the height of overhead objects such as electric wires. Check major specifications of the machine before traveling, and be careful of the overhead clearance from the objects such as the electric wires for the trains, overpasses, and tunnels.

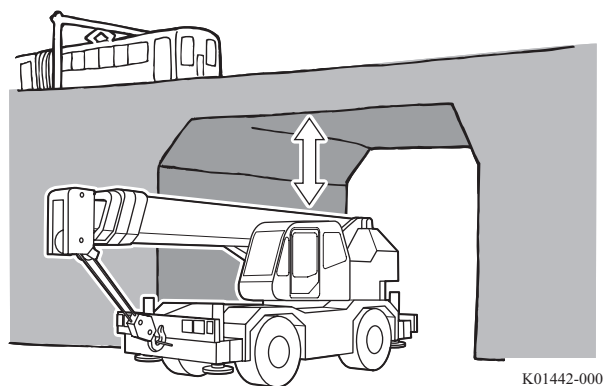

K01442-000

• If the Engine Stops While Traveling

If you drive the machine with its engine stopped on a downhill slope, etc., the air will not be supplied to the air tank, and resulting low air pressure causes a brake failure. If the engine stops during traveling, immediately stop the vehicle at a safe place.

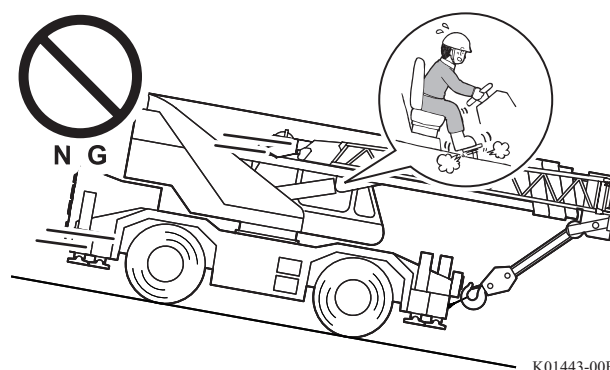

K01443-00E

• If Failure Occurs in a Tunnel

Immediately flash the hazard lamps and put a triangle reflector behind the machine to alert the following vehicles. After that, tow the machine out of the tunnel. Do not repair the machine in the tunnel. This can cause a secondary accident.

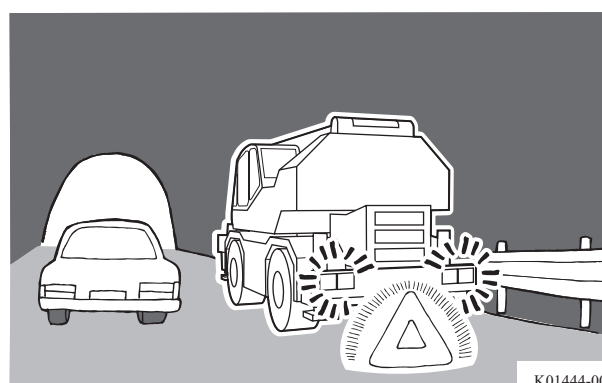

K01444-00E

• Avoid Excessive Use of Foot Brake

If you use the foot brake too frequently, the braking system overheats and the braking function can be disabled. When traveling on a long downward slope, downshift and use the engine brake together with the exhaust brake.

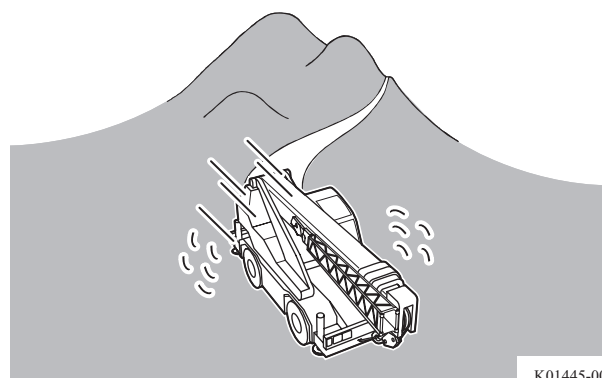

K01445-00E

• Stop the Machine Keeping Enough Distance

The head of the boom protrudes from the machine body. When you stop the vehicle while traveling on a road, make sure that the boom head does not go beyond the stop line to avoid accidents.

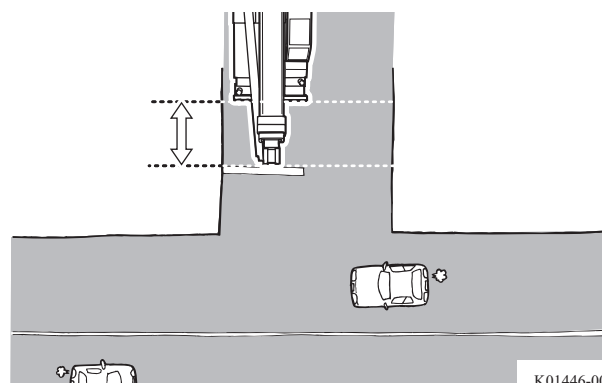

K01446-00E

• Park on Flat and Safe Place

Avoid parking the vehicle on a slope. When you park the vehicle, stop it on a level ground and apply the parking brake.

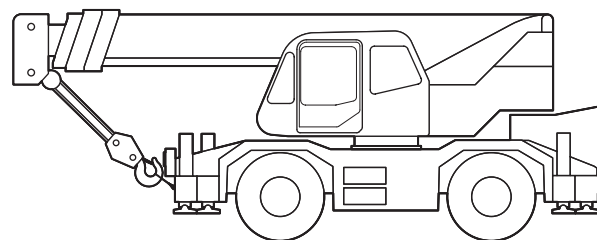

K01435-000

• Set Stoppers to All Tires If You Park on a Slope Unavoidably

When it is unavoidable to park the machine on a slope, park it parallel to the direction of the inclination. Apply the parking brake and set stoppers to the tires so that the machine does not move away.

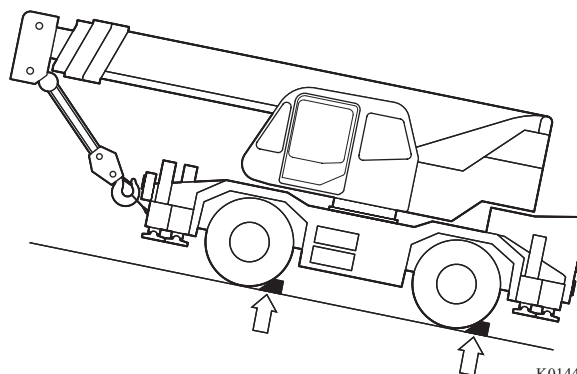

K01447-000

• Mind the Safety of Surroundings When You Park a Disabled Vehicle on a Road

When you park a disabled vehicle on a road, set up flags, fencings, flashing lamps and triangle reflectors. Make the vehicle easily noticeable from other vehicles even at night. Be careful that the parked machine does not hinder the traffic of other vehicles and pedestrians.

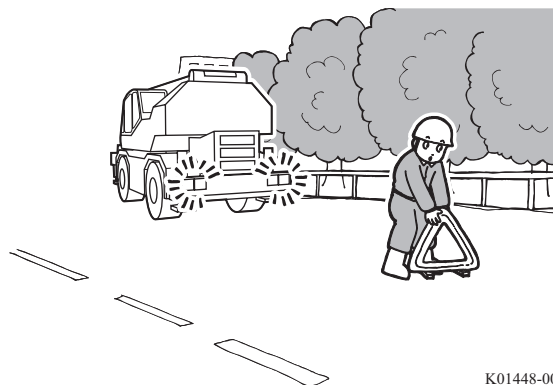

K01448-000

• When You Leave the Machine

If you leave the machine with the engine running or the starter switch key inserted, unauthorized persons can operate the machine. When you leave the machine, use the precautions below:

- Park the vehicle on a level ground and apply the parking brake.
- Apply all the brakes and locks, and set the levers to neutral position.
- Stop the engine, and pull out the key from the starter switch.
- Lock all the doors and covers.

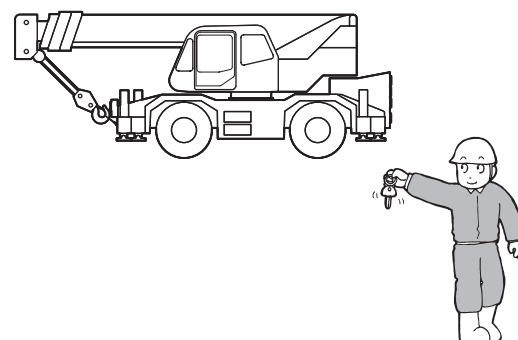

K01449-000

Precautions during Operation

• Check the Conditions of Work Site

If you operate the machine without paying attention to the surrounding conditions, an unexpected accident can occur.

Before you start the work, check by yourself the location the machine operates, the passageways, presence of obstacles, and how other machines are set up, etc.

Operate the machine while also paying attention to any changes in the surroundings during the work.

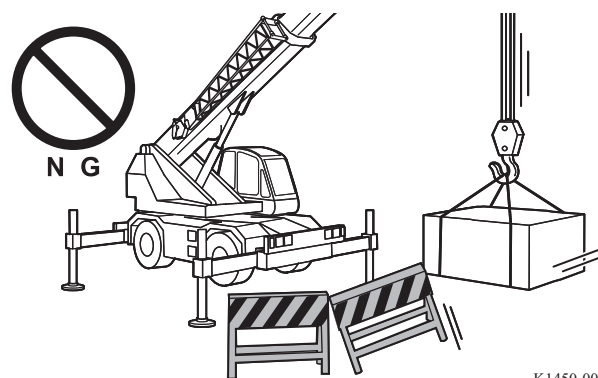

• Prohibit Unauthorized Access to Work Site

If unauthorized persons or vehicles enter the work site, accidents such as collisions, injuries or deaths can occur.

Before you start the work, check that there are no unauthorized persons or obstacles in the work site. Designate the work site as an "OFF LIMITS" zone. Also take measures to prevent unauthorized persons from gaining access, such as fencing and assignment of watchpersons.

Assign a guide person to prevent accidents while working in a site with heavy traffic.

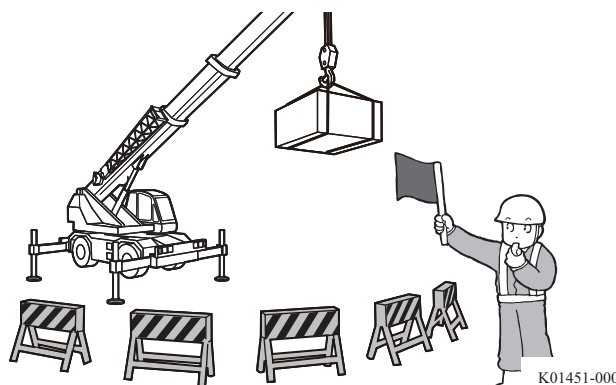

• Assign a Signal Person

Assign a signal person and make sure that the instructions from the signal person are obeyed. It is particularly important in the following cases:

- When working near electricity lines
- When the operator cannot see the lifted load
- When moving the machine into a narrow passage or in a direction where the view is not clear
- While working jointly with two or more machines

Use portable radio equipment whenever possible for communications between the signal person and operator.

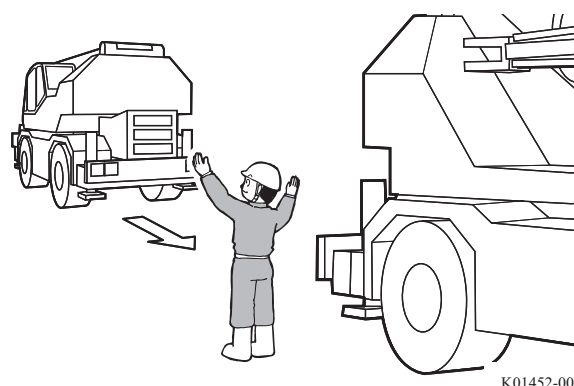

• Use Sufficient Illumination at Night

When you are in a dark area, you cannot find persons and obstacles around easily. This increases the risk of the accidents. During work at night, use work lights so that you can see the movements of the machine and lifted load clearly. And install some other illumination equipment to illuminate around the machine.

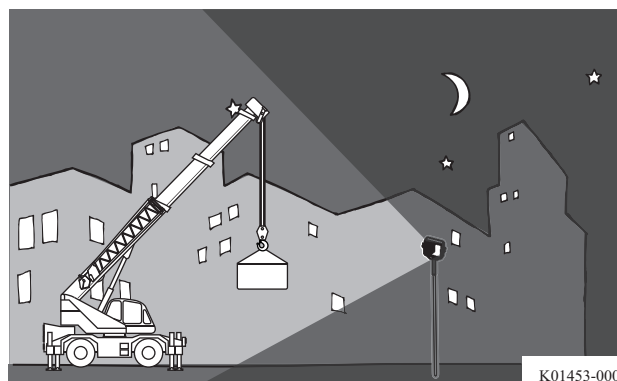

• Observe Conditions for the Work

If the width of extended outriggers, boom length, load radius, etc. are out of the specifications given in the rated lifting capacity table, the machine can overturn even if a load is not lifted.

Strictly observe the conditions for the work specified in the rated lifting capacity table.

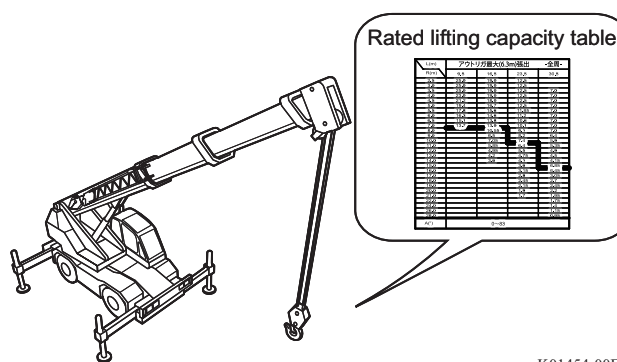

• Do Not Operate the Crane with a Load Exceeding Rated Lifting Capacity

If a load with a mass that exceeds the rated lifting capacity is lifted, the machine is overloaded and a damage to the machine or an overturning accident can occur. Check the rated lifting capacity before lifting a load. The rated lifting capacity differs depending on the boom length, load radius, and other factors. Never lift a load exceeding the values specified in the rated lifting capacity chart at any time.

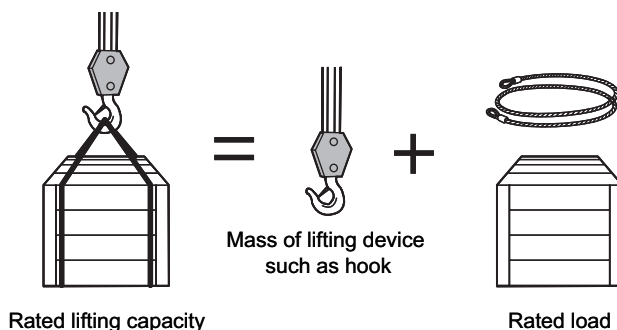

• Use Safety Devices Correctly

Correctly use the safety devices such as the load moment indicator according to the instructions described in this manual. If the safety devices are used incorrectly or their functions are obstructed, a damage to the machine or an overturning accident can occur.

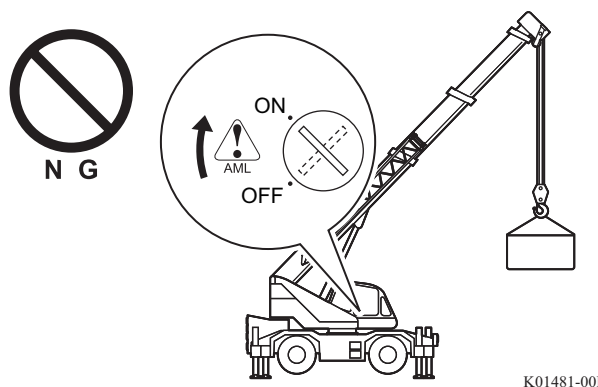

• Take Measures against Noise

To protect yourself from injury caused by noise, close the doors and windows of the operator's cab during crane operation.

If you work outside the cab, wear hearing protectors such as earplugs as necessary.

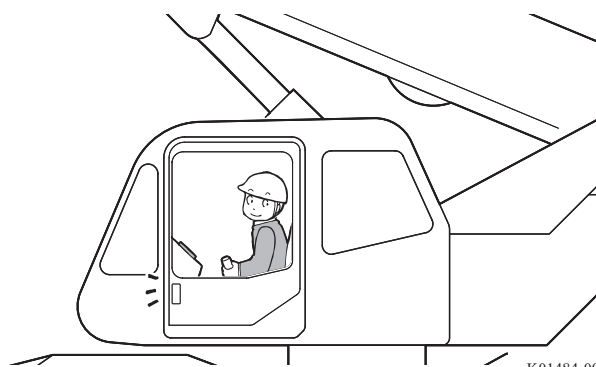

K01484-00J

• Inspection after Starting the Engine

If you neglect the inspections after starting the engine, it delays detection of machine abnormalities. This can cause a damage to the machine, or an injury or death.

Carry out inspections in a sufficiently large space without persons and obstacles around the machine.

After starting the engine, check the devices and indications on the instruments. Make sure

that no obstacles or persons are around the machine. And then, under a no-load condition, check the operation of the control systems, lifting systems, and safety systems.



G05016-000

• Check the Outrigger Set-up Condition

An improper outrigger set-up can cause an overturning accident. Check the following points.

- The machine is set up horizontally.
- The outrigger floats are in contact with the ground or the steel plates.
- All the tires are off the ground.
- The outrigger beams are fixed with lock pins.

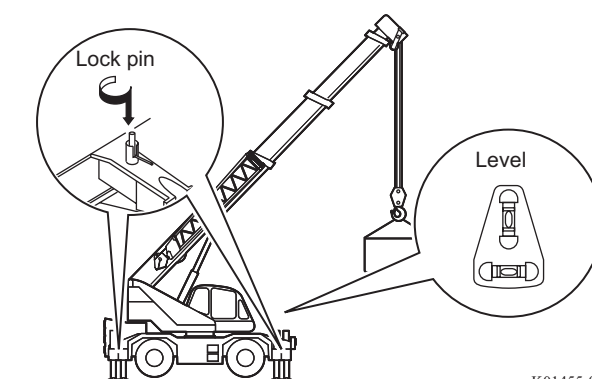

K01455-00E

• Check before Lifting a Load

Check the points below before lifting a load.

- The mass of the lifting load does not exceed the rated lifting capacity.
- The number of parts of line for the wire rope is set according to the standard number of parts of line specified in the rated lifting capacity chart.
- Proper lifting devices are used, and the load is rigged securely.
- The hook block is directly over the gravity center of the load.
- The load lines are vertical so that the load is lifted vertically.
- The safety latch of the hook block functions properly.
- The wire ropes are free of intertwining or disorderly winding.

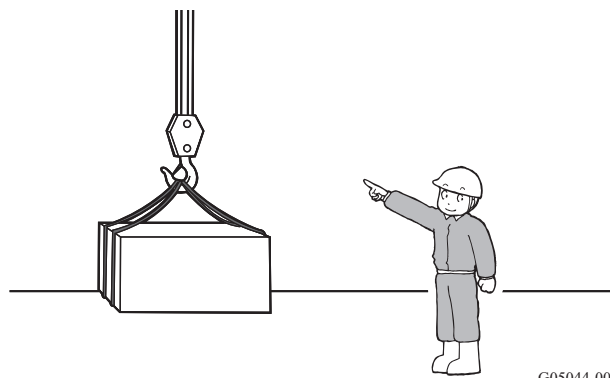

G05044-000

• Securely Rig the Load

If the rigging method is incorrect, the lifted load can fall and cause an accident. Observe the precautions below to ensure secure rigging.

- Understand the mass and gravity center of the load, and use the lifting devices best suited for the mass and shape of the load.
- The lifting devices such as wire ropes and chains must have sufficient strength and be free from damage and wear.
- Rig a load directly over its gravity center so that the lifted load does not overturn or slip out of the lifting devices when lifted off the ground.

Also, rig a load properly so that the lifting devices do not cross over each other, or are not intertwined.

- Do not rig a load with a single rope. The lifted load can turn and create hazard. Also, the turn of the load untwists the rope and reduces its strength.
- If a load has sharp corners, apply pads to the corners so that the rigging wire ropes and loads are not damaged.

• Carefully Lift a Load off the Ground by Hoisting-up Operation

When you lift up a load, be sure to hoist up the load just clear of the ground carefully first by winch operation.

Do not lift a load just clear of the ground by raising or extending the boom. Such operations can damage the machine and cause an overturning accident.

When you lift a load just clear of the ground, stop hoisting for a time when the rigging ropes are tensioned. Check that the load is hung above its gravity center, the load does not stick to the ground or does not touch other loads or structures. Lift up a load vertically, and stop lifting again when the load is raised by several centimeters above the ground and stop the sway of the load. Check that the state of rigging is fine, the load is securely held at the position, and the machine is not overloaded. And then, lift up the load again.

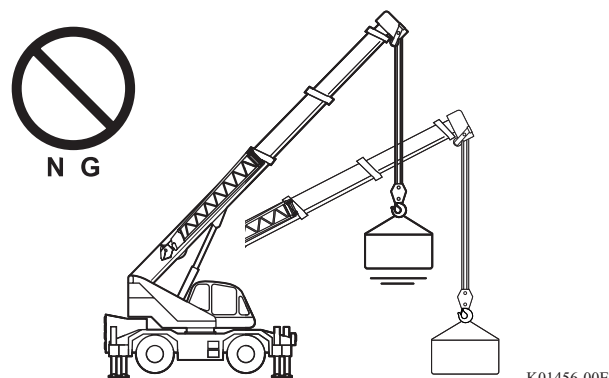

K01456-00E

• Lift a Single Load Only

Never lift two or more loads at once. Even if the total load mass is within the rated lifting capacity, the loads can lose balance and create hazard. Also, the operator cannot concentrate on all loads.

Be sure to lift a single load only.

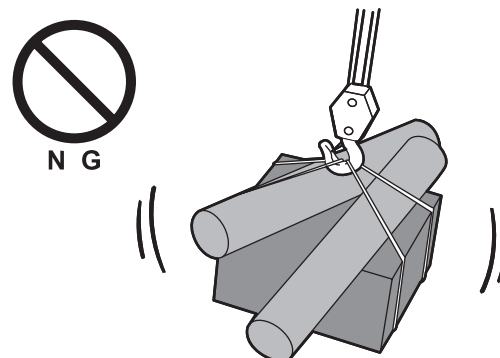

G05047-00E

• Never Lift an Buried Load

If you pull up buried objects, garden trees, or objects driven into the ground, an unexpected load can be applied to the machine. This can damage the machine and cause an overturning accident.

Do not lift objects driven into the ground such as poles or piles, and garden trees, and objects buried in mud or sand.

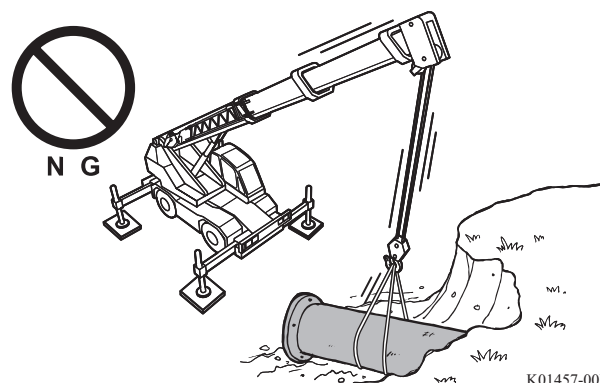

K01457-00E

• Avoid Overloading (Exceeded Capacity)

If a load close to the rated lifting capacity is lifted, an overloading can occur when the load sways. Operate the machine with extreme care.

When an overload occurs, bring down the load to the ground by winch hoist-down operation.

When extending or lowering the boom, also be careful of overloading because the load radius increases.

Rated lifting capacity table

L(m) R(m)	Outrigger fully extended (6.5 m) -360 degrees-			
	9.35	16.4	23.45	30.5
2.5	25.0	18.0	12.0	
3.0	25.0	18.0	12.0	
3.5	25.0	18.0	12.0	8.0
4.0	21.5	16.0	12.0	8.0
4.5	21.5	16.0	12.0	8.0
5.0	18.0	15.0	12.0	8.0
5.5	17.8	15.0	12.0	8.0
6.0	15.1	15.0	11.5	8.0
6.5	15.1	15.0	11.5	8.0
7.0	11.5	11.5	10.0	8.0
7.5	11.5	11.5	10.0	8.0
8.0	8.0	8.0	8.0	8.0
8.5	8.0	8.0	8.0	8.0
9.0	7.5	7.5	7.5	8.0
9.5	6.5	6.5	6.5	8.0
10.0	6.5	6.5	6.5	8.0
10.5	4.5	4.5	4.5	4.25
11.0	4.5	4.5	4.5	4.25
11.5	4.25	4.25	4.25	4.25
12.0	4.25	4.25	4.25	4.25
13.0	3.0	3.0	3.0	3.4
14.0	2.5	2.5	2.5	2.8
15.0	2.2	2.2	2.2	2.4
16.0	2.0	2.0	2.0	2.15
17.0	1.8	1.8	1.8	1.9
18.0	1.7	1.7	1.7	1.7
19.0	1.6	1.6	1.6	1.6
20.0	1.5	1.5	1.5	1.5
21.0	1.4	1.4	1.4	1.4
22.0	1.3	1.3	1.3	1.3
23.0	1.2	1.2	1.2	1.2
24.0	1.1	1.1	1.1	1.1
25.0	1.0	1.0	1.0	1.0
26.0	0.9	0.9	0.9	0.9
27.0	0.8	0.8	0.8	0.8
28.0	0.7	0.7	0.7	0.7
29.0	0.6	0.6	0.6	0.6
30.0	0.5	0.5	0.5	0.5
31.0	0.4	0.4	0.4	0.4
32.0	0.3	0.3	0.3	0.3
33.0	0.2	0.2	0.2	0.2
34.0	0.1	0.1	0.1	0.1
35.0	0.1	0.1	0.1	0.1
36.0	0.1	0.1	0.1	0.1
37.0	0.1	0.1	0.1	0.1
38.0	0.1	0.1	0.1	0.1
39.0	0.1	0.1	0.1	0.1
40.0	0.1	0.1	0.1	0.1
41.0	0.1	0.1	0.1	0.1
42.0	0.1	0.1	0.1	0.1
43.0	0.1	0.1	0.1	0.1
44.0	0.1	0.1	0.1	0.1
45.0	0.1	0.1	0.1	0.1
46.0	0.1	0.1	0.1	0.1
47.0	0.1	0.1	0.1	0.1
48.0	0.1	0.1	0.1	0.1
49.0	0.1	0.1	0.1	0.1
50.0	0.1	0.1	0.1	0.1
51.0	0.1	0.1	0.1	0.1
52.0	0.1	0.1	0.1	0.1
53.0	0.1	0.1	0.1	0.1
54.0	0.1	0.1	0.1	0.1
55.0	0.1	0.1	0.1	0.1
56.0	0.1	0.1	0.1	0.1
57.0	0.1	0.1	0.1	0.1
58.0	0.1	0.1	0.1	0.1
59.0	0.1	0.1	0.1	0.1
60.0	0.1	0.1	0.1	0.1
61.0	0.1	0.1	0.1	0.1
62.0	0.1	0.1	0.1	0.1
63.0	0.1	0.1	0.1	0.1
64.0	0.1	0.1	0.1	0.1
65.0	0.1	0.1	0.1	0.1
66.0	0.1	0.1	0.1	0.1
67.0	0.1	0.1	0.1	0.1
68.0	0.1	0.1	0.1	0.1
69.0	0.1	0.1	0.1	0.1
70.0	0.1	0.1	0.1	0.1
71.0	0.1	0.1	0.1	0.1
72.0	0.1	0.1	0.1	0.1
73.0	0.1	0.1	0.1	0.1
74.0	0.1	0.1	0.1	0.1
75.0	0.1	0.1	0.1	0.1
76.0	0.1	0.1	0.1	0.1
77.0	0.1	0.1	0.1	0.1
78.0	0.1	0.1	0.1	0.1
79.0	0.1	0.1	0.1	0.1
80.0	0.1	0.1	0.1	0.1
81.0	0.1	0.1	0.1	0.1
82.0	0.1	0.1	0.1	0.1
83.0	0.1	0.1	0.1	0.1
84.0	0.1	0.1	0.1	0.1
A")	0 - 84			



K00797-00E

• Be Careful of Simultaneous Operation

During simultaneous operation, the machine movement tends to be slower than those of independent operations. Conversely, when the simultaneous operation is switched to independent operation, the movement can become faster. When you carry out simultaneous operation, pay attention so that a sudden speed change does not occur.

Before you are sufficiently accustomed to

the machine, an operation error can occur during simultaneous operations. Do not carry out a simultaneous operation until you are familiar enough with the operation.

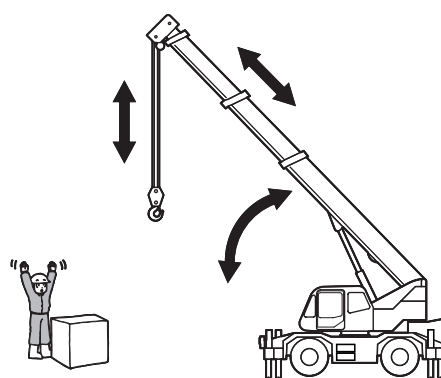

K01458-000

• Be Careful to Avoid Collisions with Structures Nearby

When moving a lifted load, be careful not to allow the machine or the lifted load to collide with a building, etc. around the machine. In a site with many such obstacles, post a signal person and follow the instructions from the signal person to prevent a collision.

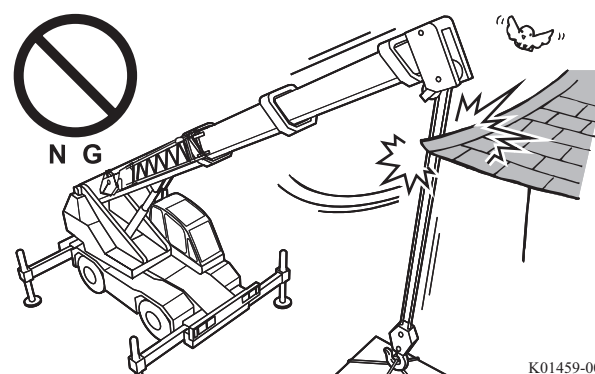

K01459-00E

• Carefully Operate While the Boom is Raised High

When the boom is raised close to its upper limit angle, the horizontal clearance between a lifted load and the boom is small. If the lifted load sways in this condition, the load can collide with the boom or jib. This can damage the boom or jib, or the load itself.

Carry out operation carefully when the boom is raised close to its upper limit angle, so that the load will not collide with the boom or jib.

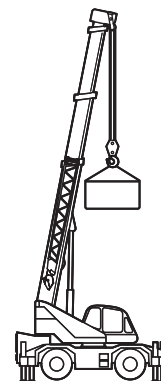

K01460-000

• Carry Out Demolition Work Carefully

It is dangerous to lift a structure during demolition work when its mass and gravity center are not known.

Check the mass and gravity center of the load before operation, and decide the lifting method accordingly.

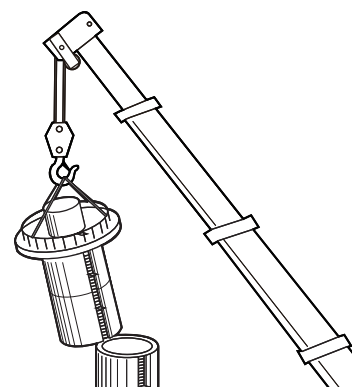

G05053-000

• Lift a Submerged Load Carefully

When you lift a load submerged under water, be aware that the load contains water and can be several times heavier than the expected mass. Do not lift a load from water in one quick operation. Drain water while slowly lifting the load.

Also, even if water is completely drained, a load raised out of water is much heavier than when it is subjected to buoyancy in water. Be extremely careful not to allow overloading to occur.

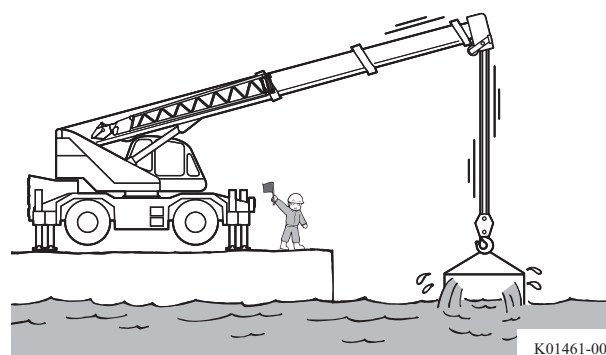

K01461-000

• Pay Attention to Long Load

Be careful when lifting a long load. A lifted load can turn and collide with the rigging workers, crane itself, and structures around the machine.

Attach guide ropes to one end or both ends of the load and keep the position of the load, and prevent the load from turning or swaying.

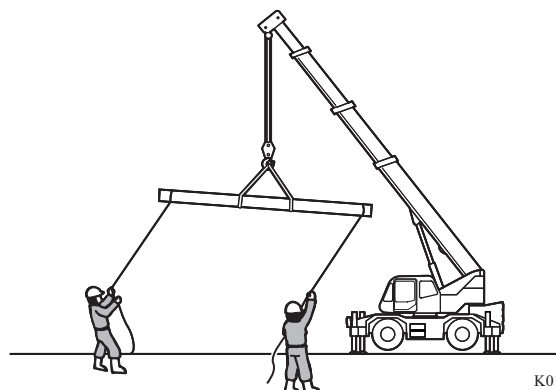

K01462-000

• Pay Attention to Dead Turns of Wire Ropes

If a wire rope is completely reeled out from the winch drum, the load is directly applied to the rope end due to loss of friction. This can damage or break the wire rope.

Make sure that three or more extra turns always remain on the winch drum. In particular, be careful when the load is lowered below the ground level.

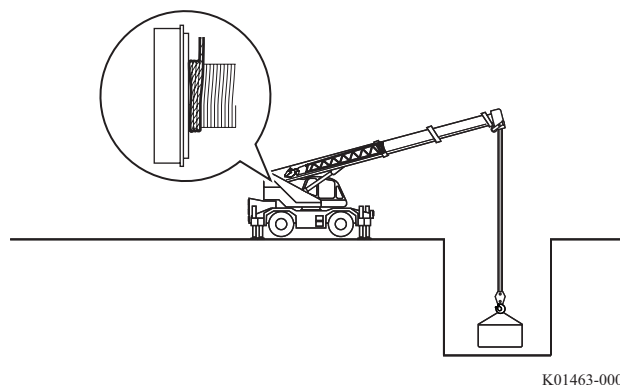

• Do Not Suspend Loads for a Long Time

Avoid keeping a load lifted for a long time. Arrange the work procedure to minimize the load-lifting time.

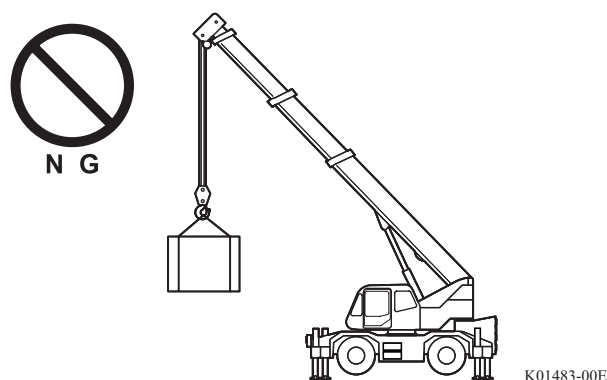

• Use the Crane Only for Its Specified Purposes

A crane is made to lift objects. Do not use it for operations other than the specified applications, such as lifting a person or pushing an object with the boom.

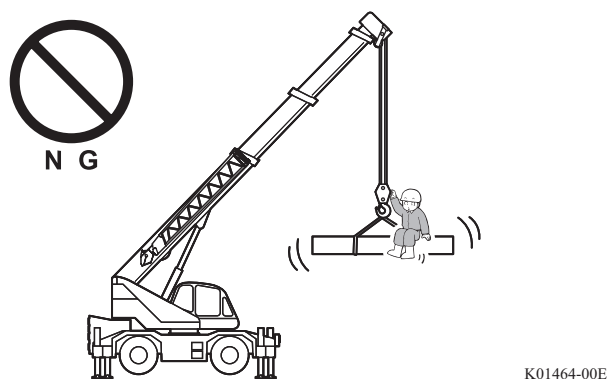

• Do Not Use Special Attachments

Operation with special attachments such as an earth auger or vibro-hammer is prohibited. Such operation can cause an overturning accident, and shorten the machine life. Note that any accident or failure caused by operations with an attachment mounted will not be covered by our warranty.

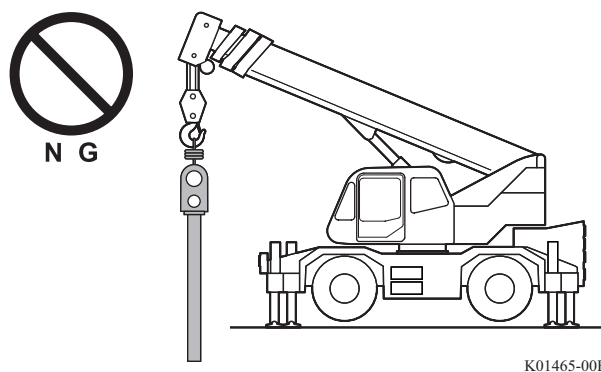

• Do Not Add Counterweight

Addition of counterweights other than the specified ones can damage the machine. This also can affect the backward stability and cause the machine to overturn to the rear. Do not install or place counterweights other than specified ones, or objects functioning as counterweights onto the machine.



K01466-00E

• Do Not Distract Your Attention

Inattentive crane operation is very dangerous. Do not look away from the signal person and lifted load, and be sure to concentrate on the operation.

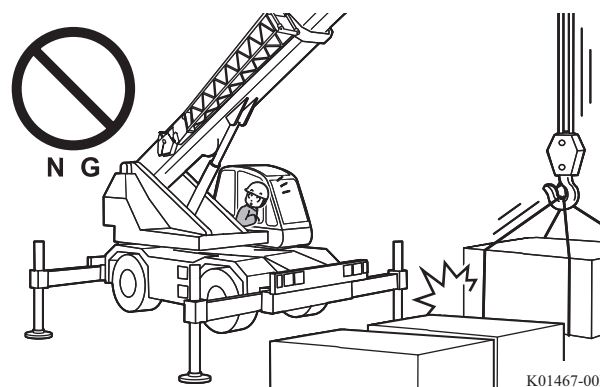

K01467-00E

• Do Not Pass a Load Over a Person

Avoid dangerous operations such as passing a hook block or a lifted load over a person. Also, do not allow anyone to enter the area under the boom or lifted load.

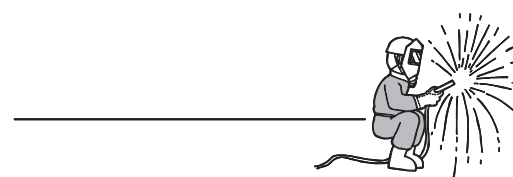
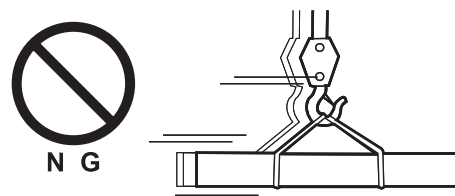

G05062-00E

• Avoid Sideways Pulling, Diagonal Lifting, and Pulling-in of Load

It is very dangerous to pull a load sideways, to lift it diagonally, or to pull-in a load. Such operations damage the boom, jib, and swing mechanism, and they may also overturn the machine.

Do not forcibly pull-in a load that lies out of the load radius. Move the machine close to the load, and lift it vertically.

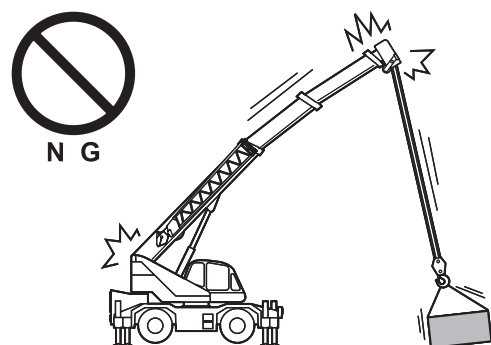

K01468-00E

• Before Leaving the Cab

Before leaving the operator's cab, take the following measures.

- Lower the load onto the ground.
- Fully retract the boom and stow them.
- Apply all the brakes and drum locks (if equipped).
- Return the control levers to the neutral position.
- Stop the engine, and pull out the key from the starter switch.
- Lock all the doors and covers.

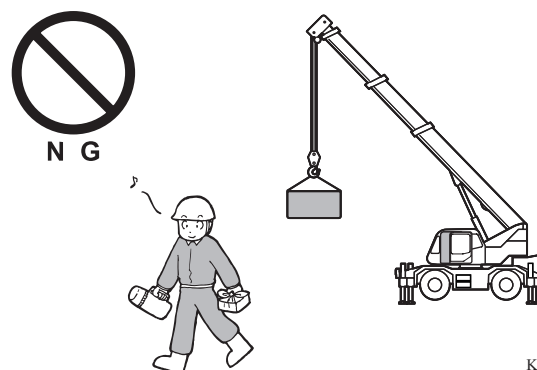

K01469-00E

• Do Not Let Person Other than Operator Get on the Machine

If any person other than the operator ride the machine, the person can be caught by or fall off the machine. Presence of other persons also hinders the operation.

Do not allow any person other than the operator to get on the machine.

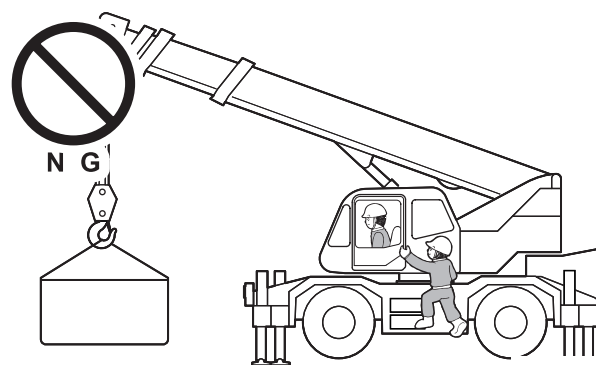

K01470-00E

• Precautions When the Jib is Mounted (1)

Do not lift individual loads using the boom and jib at the same time. The boom and jib can be damaged, and the machine can overturn.

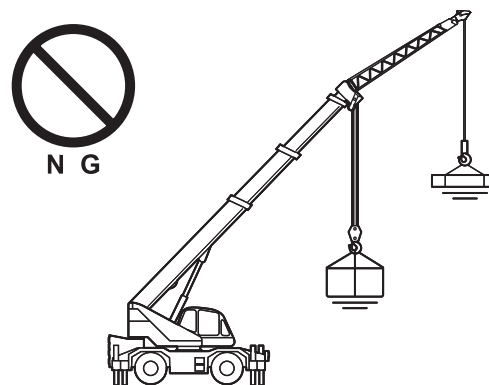

K01471-00E

• Precautions When the Jib is Mounted (2)

When you lift up a single load using both main and auxiliary winches, observe the following points in accordance with the rated lifting capacity table.

- Register the boom status as jib lift.
- Make sure that the mass of the load including the lifting devices is within the rated lifting capacity for jib lift.

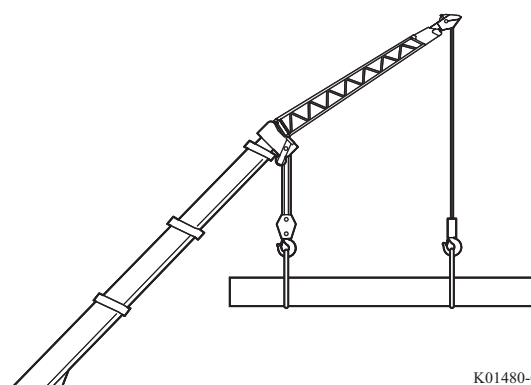

K01480-01E

If the main winch wire rope is paid out while a load is lifted, the gravity center of the load can move and cause an overload. Operate carefully so as not to cause overloading.

• Precautions When the Jib is Mounted (3)

Pay attention to the followings during lifting with the boom while the jib is mounted.

- Observe the value of the rated lifting capacity chart according to the actual boom and jib condition.
- During lifting with the boom while the jib is mounted, the crane stops just before the moment load ratio reaches 100 %.

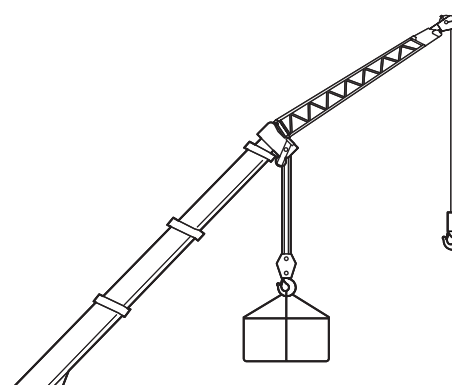

K01472-01E

• Stop Operation when Visibility Becomes Poor

When visibility becomes poor due to bad weather such as rain, snow, or fog, stop the operation and stow the machine. Wait until the visibility recovers good enough for operation.

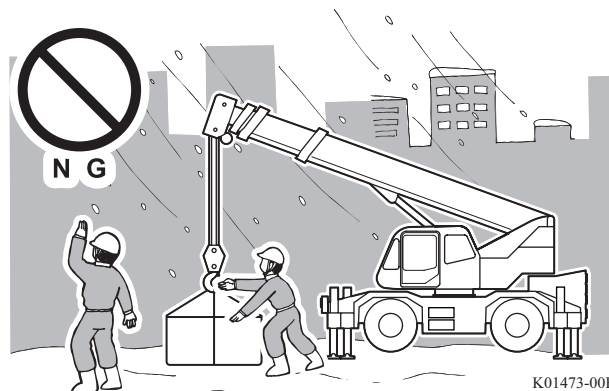

K01473-00E

• Stop Operation during Strong Wind Conditions

A strong wind sways the lifted load. This is dangerous to workers and surrounding structures, and can damage the boom and can cause the machine to overturn. Note that the longer the boom is, and the bigger the size of the load is, the more the wind affects the machine operation.

Stop the crane operation if the load becomes out of control by strong wind. Reduce the load considering the wind speed, if the wind speed exceeds 20 mph (9 m/s).

When strong winds with maximum instantaneous wind speed of 31 mph (14 m/s) or more blow, stop the operation and stow the boom.

Pay special attention when the boom is long or the lifted load has a large area. Stop the operation as the situation requires even if the wind speed is slower than 20 mph (9 m/s).

The table below shows a rough indication of wind speeds. The wind speeds shown below are at a height of 30 ft. (10 m) from an open flat ground.

Wind speed	Influence on land
12-18 mph (5-8 m/s)	Dust and loose paper raised. Small tree branches begin to move.
18-24 mph (8-11 m/s)	Low trees with leaves start to sway. Water surfaces in ponds or marshes start to make waves.
24-31 mph (11-14 m/s)	Large branches move. Whistling heard in overhead wires. Umbrella use becomes difficult.
31-38 mph (14-17 m/s)	Whole tree sways. Effort needed to walk against the wind.

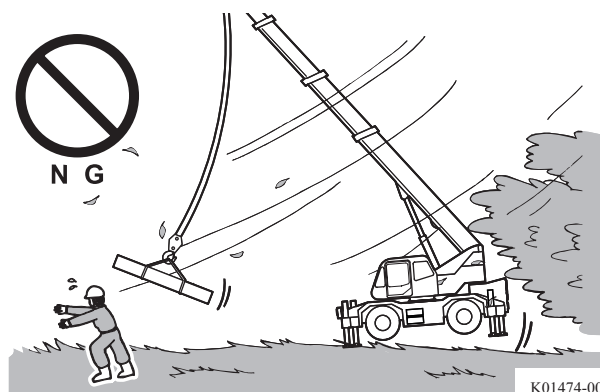

K01474-00E

• Stop the Operation when There is a Risk of Lightning Strike

If the machine is struck by lightning, the machine can be damaged, and the operator and workers around it can be injured. When there is a risk of lightning strike, stop the operation and stow the boom, and then leave the machine.

If the machine is struck by lightning, stay in the cab to avoid another lightning strike.

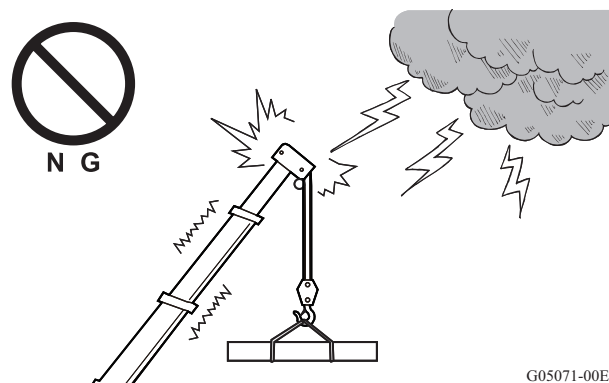

G05071-00E

• Precautions in Cold Season

- Remove any snow and ice on the machine. Particularly, remove the snow and ice on the boom completely. They can fall during operation.
- Do not touch the metal surfaces of the machine in extremely cold season. Your skin can stick to the frozen metal surface.
- Warm up the machine sufficiently. After warming up, check that the machine operates normally. Properly unfreeze and dry the components as needed.
- At the beginning, operate the machine slowly until the lubrication by oil and grease become effective.
- Check that a load is not frozen and stuck to the ground. It is dangerous to lift a load when it is stuck to the ground.
- At the end of an operation, clean the mud around the outriggers and tires to prevent accidents caused by freezing.
- Pay extra care to battery maintenance. Use oils, greases, and fuels suitable for cold climates.

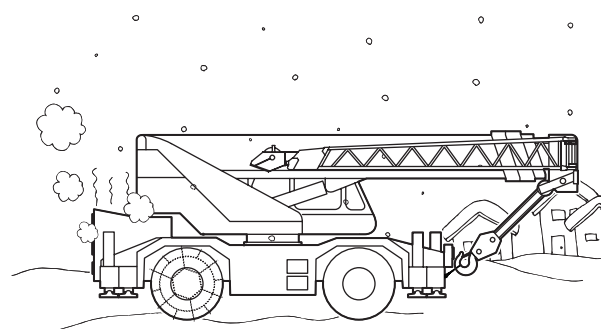

K01475-000

• Pay Attention to Avoiding Electric Shock

You can have an electric shock just by approaching the electric lines, depending on the voltage. If it is unavoidable to carry out an operation near power cables or main lines, take the preventive measures below.

Normal voltage, kV (Phase to phase)	Minimum required clearance, ft. (m)
Operation near high voltage power lines	
To 50	10 (3.05)
Over 50-200	15 (4.60)
Over 200-350	20 (6.10)
Over 350-500	25 (7.62)
Over 500-750	35 (10.67)
Over 750-1000	45 (13.72)
Operation in transit with no load and boom or mast lowered	
To 0.75	4 (1.22)
Over 0.75-50	6 (1.83)
Over 50-345	10 (3.05)
Over 345-750	16 (4.87)
Over 750-1000	20 (6.10)

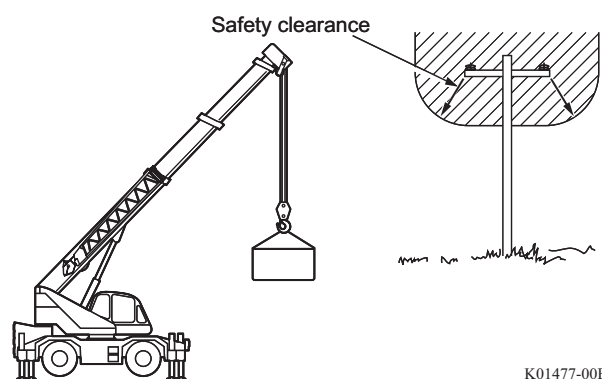
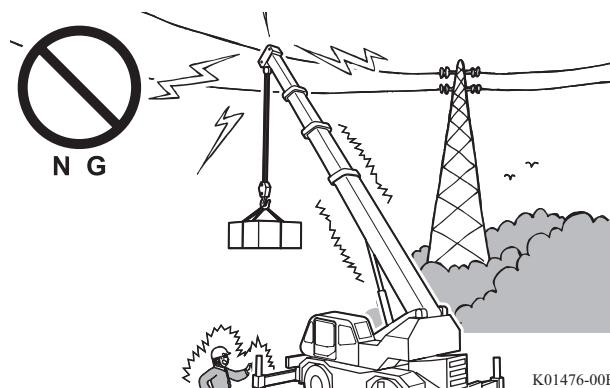

- Have a detailed consultation with the power company in advance, and take necessary measures to ensure safety.
- Make sure that related workers such as riggers wear rubber or leather shoes.
- Always keep a specified or larger clearance between a power line and a lifted load or a machine during operation.
- Assign a dedicated watchperson to prevent a machine and a lifted load from approaching an electric line, and unauthorized persons from entering the work area.
- Do not allow workers on the ground to touch the machine or a lifted load. If it is necessary to control a lifted load, attach a dry fiber rope to a load as a guide rope to prevent a load from turning and swaying.
- Do not place loads below electric lines or near power sources.
- Operate a machine slowly and cautiously, with extreme care.

If you get an electric shock, do not panic and take the measures below.

- The operator should keep calm and slowly move the machine and a lifted load away from the power line as far as the specified clearance or more, and then escape from the cab.
- If the machine is damaged and cannot be operated, it is the safest for the operator to stay on the operator's seat until the power line is deenergized. If this is not possible, jump off as far as possible from the machine body. It is dangerous to climb down the machine body. It may result in getting electric shock.
- Make all workers away from the site to prevent secondary accidents. Moreover, keep anyone away from the electrified machine and lifted load.

- Contact the power company to have the power transmission stopped, and receive emergency instructions.
- Afterwards, inform a TADANO distributor or dealer of the accident, and seek advice on follow-up measures, inspection, and repair.

• Pay Attention to High-Power Radio Waves

Induction current is generated in the structural part of the machine near high power radio wave generating sources such as television and radio transmission towers. It may cause an electric shock by electrification, or burns by the heated-up machine parts, such as the hook block. Also, electronic equipment can be destroyed.

When carrying out an operation near high-power radio wave generating sources, contact the broadcasting company in advance and seek advice about safety.

When operating, take preventive measures such as wearing rubber gloves to avoid electric shocks and burns.

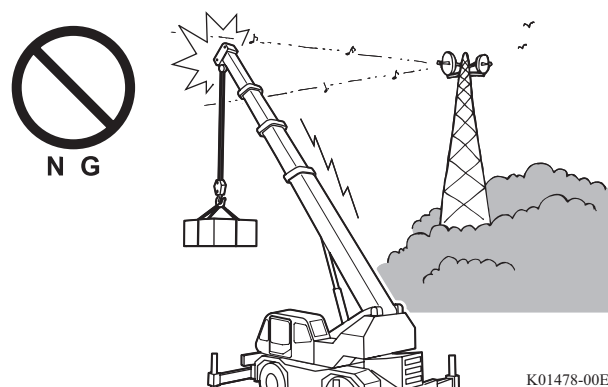

K01478-00E

• Be more Careful for Multi-crane Operation

It is dangerous to use 2 or more machines to lift a load. As far as possible, do not do such an operation. Multi-crane operation has high risks because of the deviations of the gravity center. It can cause a machine overturning, dropping of lifted loads, and damage to the boom.

If a multi-crane operation is unavoidable, observe the following points with the closest attention.

- Make detailed arrangements with the related workers about the operating methods in advance.
- Assign a supervisor and follow the supervisor's instructions. If necessary, make all the related workers carry communication equipment.
- Set up the machine horizontally on a solid ground with outriggers fully extended.
- Use machines of the same type and the same performance with sufficient capacity for the loads. Set all the boom length, boom angle, and number of parts of line to be equal.
- Lift the load in the way that the wire ropes of each machine are always vertical.
- Rig the load so that each machine evenly bears the load.
- Move the load by hoisting operation and boom elevating operation, and avoid swing operation wherever possible. Do not do simultaneous operations of hoisting, boom elevating, swinging, etc.
- Operate each crane simultaneously so that the load is borne evenly by both machines.

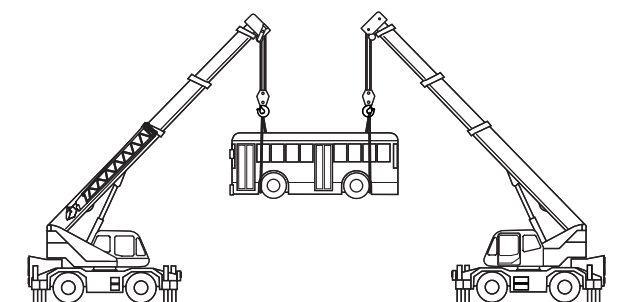

K01479-000

- **Stow the Machine after Operation is Completed**

It is dangerous to leave the machine in the operating configuration. Stow the machine after the operation is completed.

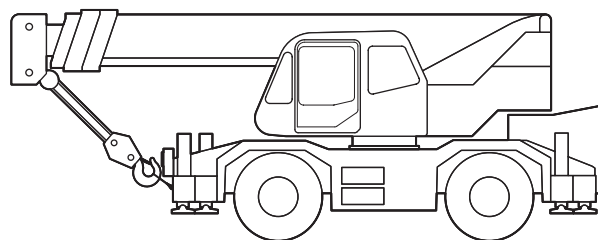

K01435-000

Warning Labels

The warning labels attached on the machine describe important warning items concerning safety.

This section describes locations and contents of the warning labels. Fully understand the notices described on the warning labels, which are very important to prevent accidents.

Check that these warning labels are not soiled. If the warnings are unreadable or the pictures are not clear, clean them.

When the warning labels are damaged or missing, replace them with new ones. Order new warning labels from your nearest TADANO distributor or dealer.

Label Location and Content of Warnings

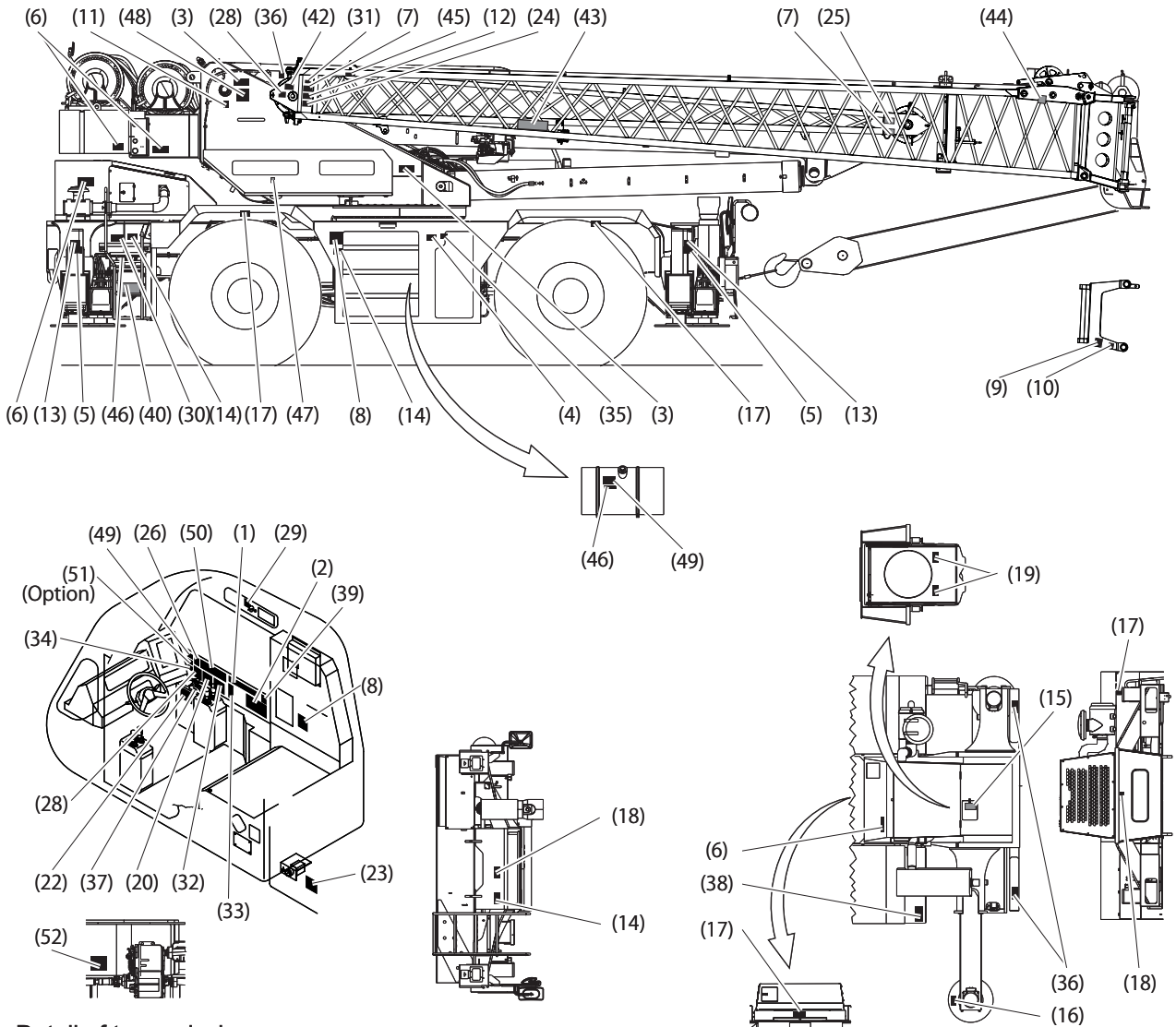

Detail of transmission

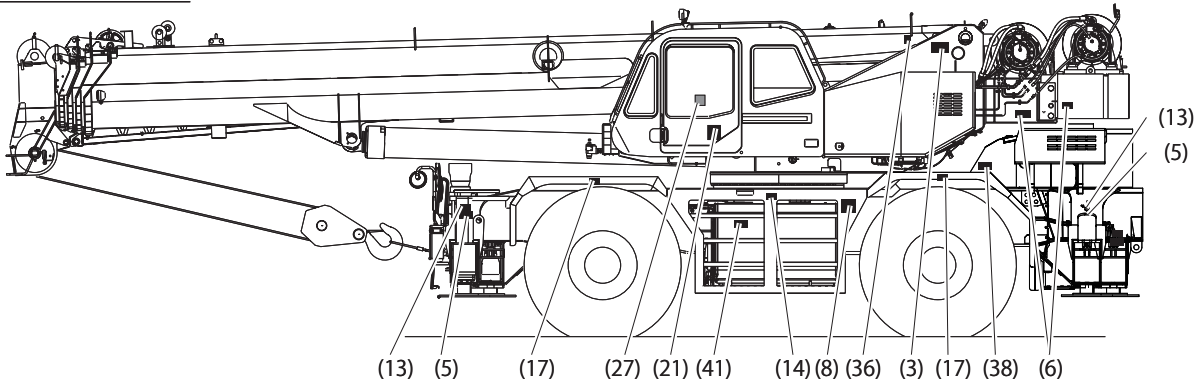

K07013-00E

GR-750XL-2_OM2(U)-17E

- (1)  DANGER Cautions
- (2)  DANGER Qualification for operator
- (3)  DANGER Being crushed by boom (3 points)
- (4)  DANGER Inflating tires
- (5)  DANGER Being hit by falling load (4 points)
- (6)  DANGER Being crushed by swinging boom (6 points)
- (7)  DANGER Caution for jib mounting and stowing (2 points)
- (8)  DANGER Power lines (3 points)
- (9)  DANGER Prevention of jib falling
- (10)  DANGER Caution for falling jib
- (11)  WARNING Falling hazard
- (12)  WARNING Caution for jib mounting
- (13)  WARNING Being crushed by outrigger (4 points)
- (14)  WARNING Prohibition of climbing up/down moving machine (4 points)
- (15)  WARNING Hot water
- (16)  WARNING Being crushed by outrigger float (4 points)
- (17)  WARNING Tripping hazard (6 points)
- (18)  WARNING Being crushed by machine (2 points)
- (19)  WARNING Radiator fans
- (20)  WARNING Outriggers
- (21)  WARNING Load moment indicator as an aid to operator
- (22)  WARNING Swing lock
- (23)  WARNING Override key switch
- (24)  WARNING Caution for jib pivot pin
- (25)  WARNING Caution for top jib mounting
- (26)  WARNING Emergency operation warning lamp
- (27)  WARNING Stow control levers
- (28)  WARNING Caution for jib set status (2 points)
- (29)  WARNING Jib status selection
- (30)  WARNING Watch your head
- (31)  WARNING Caution for jib mounting
- (32)  WARNING Ventilation
- (33)  WARNING Tightening wheel nuts
- (34)  WARNING DPF Manual Regeneration
- (35)  WARNING Use of genuine brake fluid
- (36)  WARNING Falling hazard (4 points)
- (37)  CAUTION Prohibition of shift lever neutral traveling
- (38)  CAUTION Burn hazard (2 points)
- (39)  CAUTION Wedge and socket
- (40)  CAUTION Prohibition of jump start
- (41)  CAUTION Hydraulic oil
- (42)  CAUTION Caution for jib pin handling
- (43)  CAUTION Caution for jib pin status
- (44)  CAUTION Precautions for jib offset operation (2 points)
- (45)  CAUTION Caution for wire rope reeving
- (46)  CAUTION No fire (2 points)
- (47)  CAUTION Replacing filter element and hydraulic oil
- (48) CAUTION Caution for auxiliary winch rope stowing
- (49) CAUTION Handling of fuel (2 points)
- (50) CAUTION Caution in travel
- (51) CAUTION Limit of rated lifting capacity
- (52) CAUTION Emergency transmission operation
- (53) CAUTION Bleeding hydraulic pump

(1) Cautions

⚠ DANGER	⚠ DANGER	⚠ CAUTION
DO NOT LIFT PEOPLE. ACCIDENT MAY RESULT CAUSING INJURY.	STAY AWAY FROM MACHINE IF CLOSE TO POWER LINE. MACHINE, LOAD AND GROUND MAY BECOME ELECTRIFIED AND DEADLY.	ALWAYS DISENGAGE THE HYDRAULIC PUMPS TO PREVENT UNEXPECTED CRANE MOTIONS WHILE TRAVELING.
		<small>343-912-01230 343-912-01230-1</small>

(2) Qualification for operator

⚠ DANGER
DO NOT OPERATE THIS CRANE UNLESS
<ul style="list-style-type: none"> • YOU HAVE BEEN TRAINED IN ITS SAFE OPERATION. • YOU KNOW AND FOLLOW THE SAFETY AND RECOMMENDATIONS CONTAINED IN THE TADANO INSTRUCTION MANUALS. • YOU ARE FAMILIAR WITH THE OSHA RULES FOR A SAFE WORKPLACE. AN UNTRAINED OPERATOR SUBJECTS HIMSELF AND OTHERS TO DEATH OR SERIOUS INJURY.
<small>343-912-01261 343-912-01261-0</small>

(5) Being hit by falling load

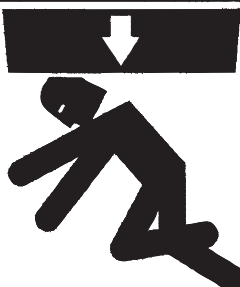
	⚠ DANGER
	FALLING LOAD OR BOOM CAN CAUSE SEVERE PERSONAL INJURY OR DEATH. STAY CLEAR OF LOAD AND BOOM.
	<small>343-912-02101 343-912-02101-0</small>

(3) Being crushed by boom

	⚠ DANGER
	KEEP CLEAR OF LOWERING OR RAISING BOOM TO AVOID SERIOUS INJURY.
	<small>343-912-01430 343-912-01430-0</small>

(6) Being crushed by swinging boom

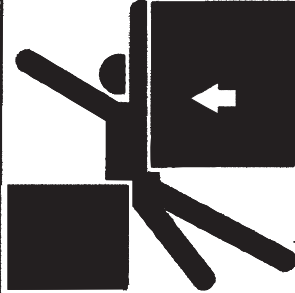
	⚠ DANGER
	SWINGING STRUCTURE STAY CLEAR TO PREVENT SEVERE PERSONAL INJURY OR DEATH.
	<small>343-912-02171 343-912-02171-0</small>



(4) Inflating tires

⚠ DANGER
HIGH PRESSURE CAN CAUSE SEVERE INJURY OR DEATH. STAY CLEAR WHEN INFLATING TIRES. ALWAYS USE AN AIR CHUCK AND TIRE CAGE RIM SIDE OR LOCK RING CAN BLOW OUT.
<small>343-912-02031 343-912-02031-0</small>

(7) Caution for jib mounting and stowing

⚠ DANGER
WHEN MOUNTING OR STOWING THE JIB, YOU SHOULD KNOW AND FOLLOW THE TADANO INSTRUCTION MANUAL. FAILURE TO FOLLOW THE TADANO INSTRUCTION MANUAL MAY RESULT IN PROPERTY DAMAGE AND OR PERSONAL INJURY OR DEATH.
<small>343-954-11700 343-954-11700-0</small>

(8) Power lines

	<h1>⚠ DANGER</h1>																											
	<p style="text-align: center;">ELECTROCUTION HAZARD</p> <p>CAN CAUSE SERIOUS INJURY OR DEATH. NEVER OPERATE THIS CRANE WITHIN ANY DISTANCE OF A POWER SOURCE OR POWER LINE, WITHOUT FIRST NOTIFYING THE POWER OR UTILITY COMPANY. THIS MACHINE IS NOT EQUIPPED WITH ANY WARNING OR INSULATING DEVICES. ALLOW FOR BOOM DEFLECTION, ELECTRICAL POWER LINE, AND LOAD LINE SWAYING. REQUIRED CLEARANCE FOR NORMAL VOLTAGE IN OPERATION NEAR HIGH VOLTAGE POWER LINES AND OPERATION IN TRANSIT WITH NO LOAD AND BOOM OR MAST LOWERED.</p> <table border="1" style="width: 100%; border-collapse: collapse;"> <thead> <tr> <th style="text-align: center;">NORMAL VOLTAGE, KV (PHASE TO PHASE)</th> <th style="text-align: center;">MINIMUM REQUIRED CLEARANCE, ft (m)</th> </tr> </thead> <tbody> <tr> <td colspan="2" style="text-align: center;">OPERATION NEAR HIGH VOLTAGE POWER LINES</td> </tr> <tr> <td style="text-align: center;">TO 50</td> <td style="text-align: center;">10 (3.05)</td> </tr> <tr> <td style="text-align: center;">OVER 50-200</td> <td style="text-align: center;">15 (4.60)</td> </tr> <tr> <td style="text-align: center;">OVER 200-350</td> <td style="text-align: center;">20 (6.10)</td> </tr> <tr> <td style="text-align: center;">OVER 350-500</td> <td style="text-align: center;">25 (7.62)</td> </tr> <tr> <td style="text-align: center;">OVER 500-750</td> <td style="text-align: center;">35 (10.67)</td> </tr> <tr> <td style="text-align: center;">OVER 750-1000</td> <td style="text-align: center;">45 (13.72)</td> </tr> <tr> <td colspan="2" style="text-align: center;">OPERATION IN TRANSIT WITH NO LOAD AND BOOM OR MAST LOWERED</td> </tr> <tr> <td style="text-align: center;">TO 0.75</td> <td style="text-align: center;">4 (1.22)</td> </tr> <tr> <td style="text-align: center;">OVER 0.75-50</td> <td style="text-align: center;">6 (1.83)</td> </tr> <tr> <td style="text-align: center;">OVER 50-345</td> <td style="text-align: center;">10 (3.05)</td> </tr> <tr> <td style="text-align: center;">OVER 345-750</td> <td style="text-align: center;">16 (4.87)</td> </tr> <tr> <td style="text-align: center;">OVER 750-1000</td> <td style="text-align: center;">20 (6.10)</td> </tr> </tbody> </table> <p>NEVER OPERATE, SERVICE OR MAINTAIN THIS CRANE WITHOUT PROPER INSTRUCTIONS. IT IS THE EMPLOYER'S RESPONSIBILITY TO PROVIDE ALL SAFETY DEVICES OR MEANS THAT MAY BE NECESSARY OR REQUIRED FOR ANY USE, OPERATION, SET-UP OR SERVICE.</p>	NORMAL VOLTAGE, KV (PHASE TO PHASE)	MINIMUM REQUIRED CLEARANCE, ft (m)	OPERATION NEAR HIGH VOLTAGE POWER LINES		TO 50	10 (3.05)	OVER 50-200	15 (4.60)	OVER 200-350	20 (6.10)	OVER 350-500	25 (7.62)	OVER 500-750	35 (10.67)	OVER 750-1000	45 (13.72)	OPERATION IN TRANSIT WITH NO LOAD AND BOOM OR MAST LOWERED		TO 0.75	4 (1.22)	OVER 0.75-50	6 (1.83)	OVER 50-345	10 (3.05)	OVER 345-750	16 (4.87)	OVER 750-1000
NORMAL VOLTAGE, KV (PHASE TO PHASE)	MINIMUM REQUIRED CLEARANCE, ft (m)																											
OPERATION NEAR HIGH VOLTAGE POWER LINES																												
TO 50	10 (3.05)																											
OVER 50-200	15 (4.60)																											
OVER 200-350	20 (6.10)																											
OVER 350-500	25 (7.62)																											
OVER 500-750	35 (10.67)																											
OVER 750-1000	45 (13.72)																											
OPERATION IN TRANSIT WITH NO LOAD AND BOOM OR MAST LOWERED																												
TO 0.75	4 (1.22)																											
OVER 0.75-50	6 (1.83)																											
OVER 50-345	10 (3.05)																											
OVER 345-750	16 (4.87)																											
OVER 750-1000	20 (6.10)																											
	<h1>⚠ DANGER</h1>																											
	<p>THIS MACHINE IS NOT EQUIPPED WITH ANY WARNING OR INSULATING DEVICES. EXTREME CAUTION MUST BE EXERCISED BY ALL PERSONNEL WORKING WITH AND AROUND THIS MACHINE WHEN IN THE PROXIMITY OF ENERGIZED POWER SOURCE OR POWER LINES. DEATH OR SERIOUS INJURY CAN RESULT FROM CONTACT OR INADEQUATE CLEARANCE. ALL PERSONNEL MUST BE ADEQUATELY WARNED OF SAFETY PROCEDURES.</p>																											

343-968-72200

343-968-72200-0

GR-750XL-2_OM2(U)-17E

(9) Prevention of jib falling

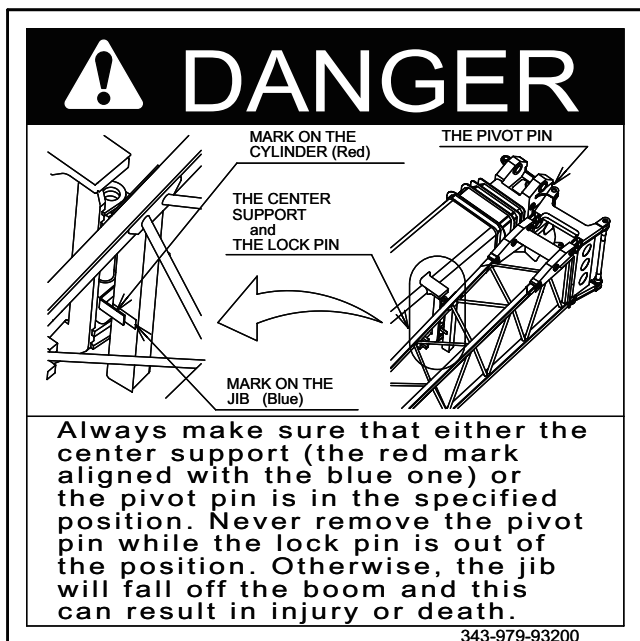

343-979-93200-0

(11) Falling hazard



323-913-32030-0

(10) Caution for falling jib



343-979-93300-0

(12) Caution for jib mounting

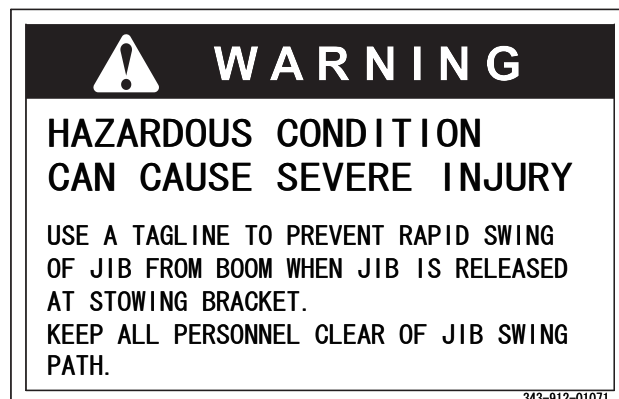

343-912-01071-0

(13) Being crushed by outrigger



343-912-02090-0

(14) Prohibition of climbing up/down moving machine

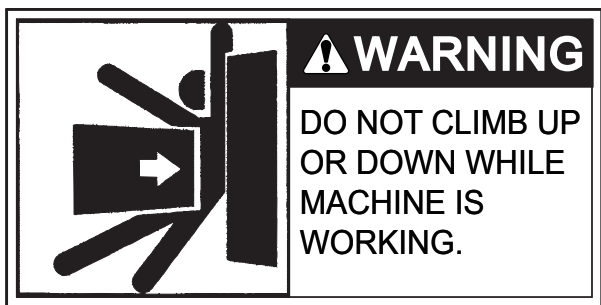

343-912-02120
343-912-02120-0

(18) Being crushed by machine



343-912-02180
343-912-02180-0

(15) Hot water

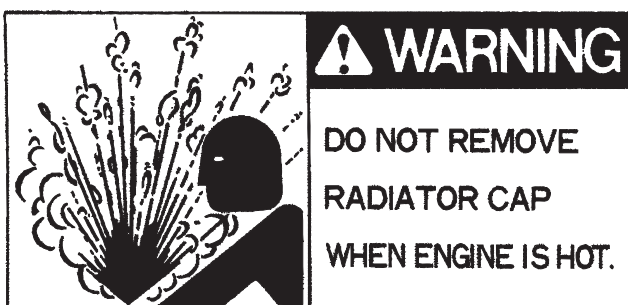

343-912-02130
343-912-02130-1

(19) Radiator fans



343-912-02201
343-912-02201-1

(16) Being crushed by outrigger float



343-912-02150
343-912-02150-0

(20) Outriggers



343-925-31361
343-925-31361-0

(17) Tripping hazard



343-912-02160
343-912-02160-1

GR-750XL-2_OM2(U)-17E

(21) Load moment indicator as an aid to operator

! WARNING

ELECTRONIC EQUIPMENT ON THIS MACHINE IS INTENDED AS AN AID TO THE OPERATOR

Under no condition should it be relied upon to replace use of capacity charts and operating instruction.

Sole reliance upon these electronic aids in place of good operating practices can cause an accident.

343-925-31450
343-925-31450-0

(22) Swing lock

! WARNING

DO NOT ATTEMPT TO ENGAGE SWING LOCK WHILE SUPERSTRUCTURE IS IN MOTION.

SWING LOCK MUST BE ENGAGED, WITH BOOM POSITIONED FRONTWARD, WHEN DOING PICK AND CARRY, TRAVELING OR TRANSPORTING.

343-937-61210
343-937-61210-0

(23) Override key switch

! WARNING

THIS KEY SWITCH BYPASSES CONTROL LEVER LOCKOUT FUNCTION OF LOAD MOMENT INDICATOR (AML). THE SWITCH MAY ONLY BE USED BY AUTHORIZED PERSONNEL DURING EMERGENCY SITUATIONS. FAILURE TO FOLLOW THIS INSTRUCTION MAY RESULT IN PROPERTY DAMAGE AND OR PERSONAL INJURY.

343-941-91320
343-941-91320-1

(24) Caution for jib pivot pin

! WARNING

FALLING OBJECT CAN CAUSE SEVERE INJURY. MAKE SURE JIB PIVOT PIN IS INSTALLED ON BOOM HEAD'S SIDE TOWARD JIB BEFORE DISCONNECTING JIB FROM STOWING BRACKET.

343-941-91360
343-941-91360-1

(25) Caution for top jib mounting

! WARNING

HAZARDOUS CONDITION CAN CAUSE SEVERE INJURY

USE A TAGLINE TO PREVENT RAPID SWING OF TOP JIB FROM BASE JIB WHEN TOP JIB IS RELEASED AT CONNECTING PIN. KEEP ALL PERSONNEL AWAY FROM TOP JIB SWING PATH.

343-954-11500
343-954-11500-0

(26) Emergency operation warning lamp

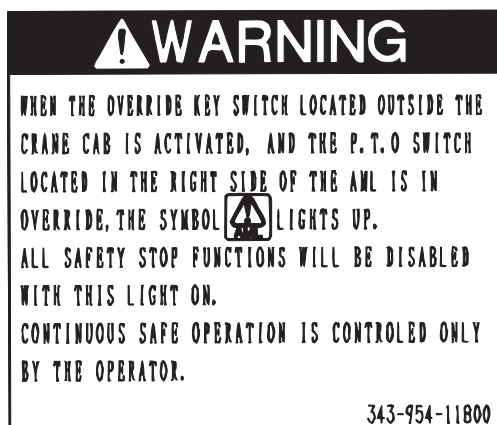

(29) Jib status selection

Select correct jib status, or Load Moment Indicator does not function precisely and may cause critical condition.

WARNING
343-957-52400

343-957-52400-0

(27) Stow control levers

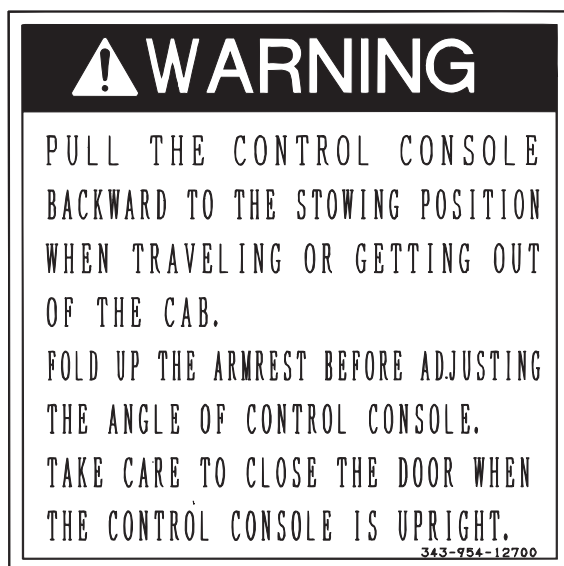

343-954-12700-0

(30) Watch your head



(31) Caution for jib mounting



343-958-41020-1

(28) Caution for jib set status

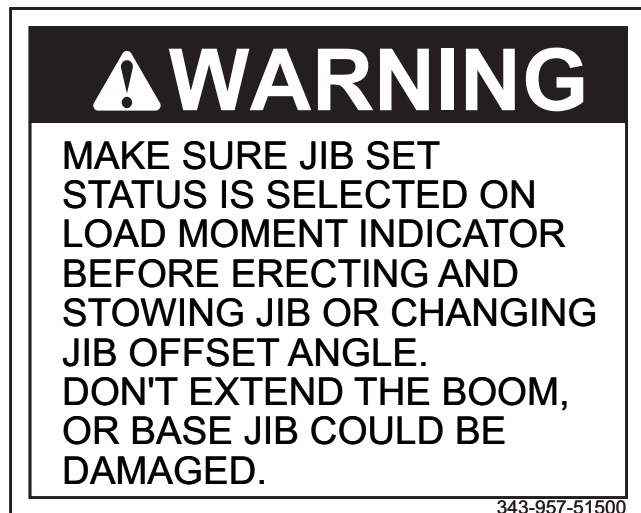

343-957-51500-1

(32) Ventilation

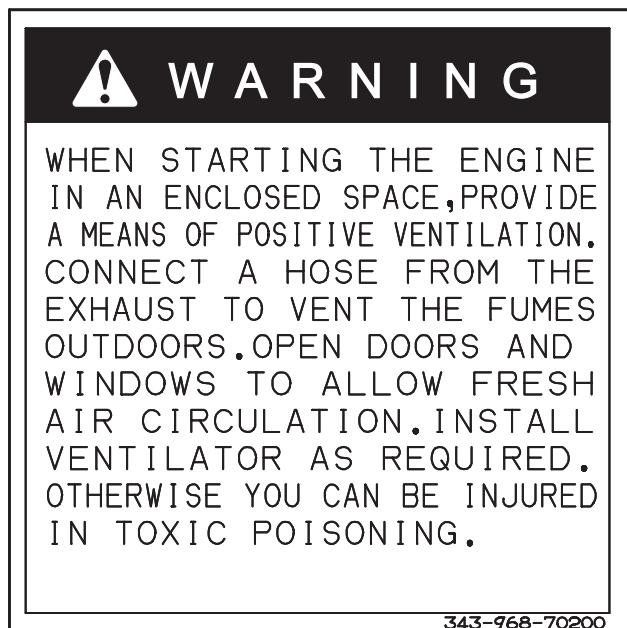

343-968-70200-0

(34) DPF Manual Regeneration



343-979-61050-0

(33) Tightening wheel nuts

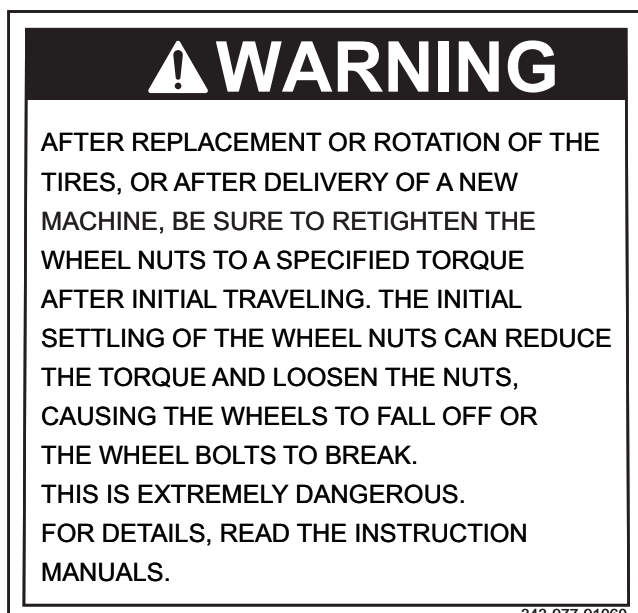

343-977-91060-0

(35) Use of genuine brake fluid



370-022-11751-1

(36) Falling hazard



370-022-13400-0

(39) Wedge and socket



343-941-91350
343-941-91350-0

(40) Prohibition of jump start

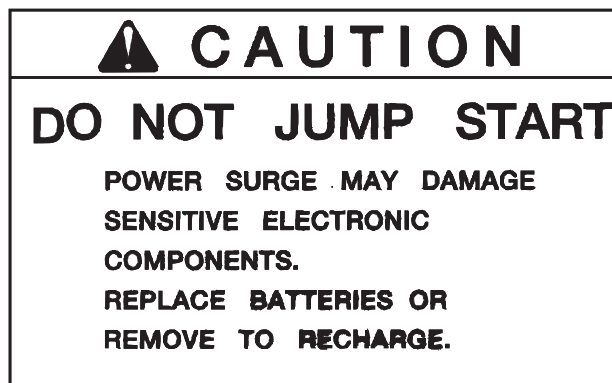

343-941-92030
343-941-92030-0

(37) Prohibition of shift lever neutral traveling

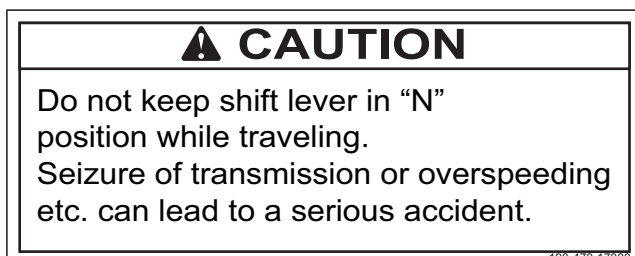

190-470-17000
190-470-17000-1

(41) Hydraulic oil

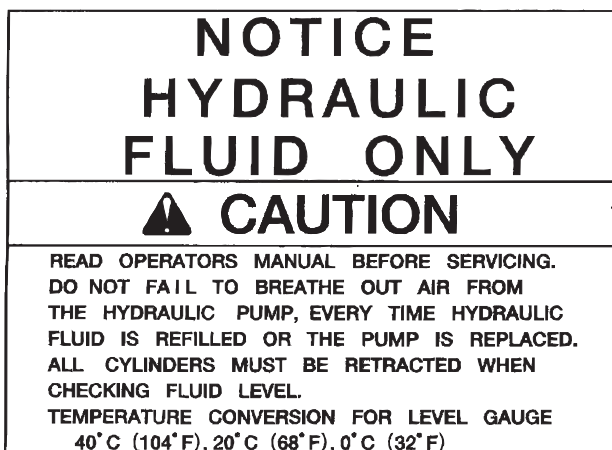

343-941-92040
343-941-92040-0

(38) Burn hazard



343-927-88610
343-927-35010-1

(42) Caution for jib pin handling

<h2 style="margin: 0;">⚠ CAUTION</h2> <h3 style="margin: 5px 0;">JIB HANDLING INSTRUCTIONS</h3> <p>◆ Before operating crane or traveling on road, check stowing pin A, B, C and pivot pin D. Jib will fall off if operation or travel is started with these pins out of position.</p> <p>◆ When handling the pins A, B, C and D. 1. Retract the boom completely. 2. Do not lower the boom below 0°.</p> <p>◆ When stowing the jib, insert stowing pin A, B and C to secure jib to the boom.</p>	<p style="text-align: right; margin-top: 10px;">343-954-12500</p>
--	---

343-954-12500-0

(43) Caution for jib pin status

<h2 style="margin: 0;">⚠ CAUTION</h2> <h3 style="margin: 0;">JIB PIN STATUS</h3>		
<h4 style="margin: 0;">BASE+TOP JIB STOWING</h4> <p style="font-size: small; margin-top: 5px;"> * → means pin is inserted. * ← means pin is extracted. </p>	<h4 style="margin: 0;">BASE JIB MOUNTING</h4> <p style="font-size: small; margin-top: 5px;"> * → means pin is inserted. * ← means pin is extracted. </p>	<h4 style="margin: 0;">BASE+TOP JIB MOUNTING</h4> <p style="font-size: small; margin-top: 5px;"> * → means pin is inserted. * ← means pin is extracted. </p>

343-954-12600
343-954-12600-0

(44) Precautions for jib offset operation

! CAUTION

For jib offset(tilt) 25°,45° operation, be sure to store single top. Never fail to install offset(tilt) lock pin at 3.5°,25° or 45° position to prevent the jib from falling and causing injury or equipment damage.

343-957-51400

343-957-51400-0

(48) Caution for auxiliary winch rope stowing

! CAUTION

STOWING AUXILIARY WINCH WIRE ROPE

1. Pass over auxiliary winch wire rope to rope arresters.
2. Attach rope socket to stowing support.
3. Take in rope until rope is a little slack. Take care not to overtension rope.

343-977-91020

343-977-91020-1

(45) Caution for wire rope reeving

! CAUTION

343-957-52600

343-957-52600-0

(49) Handling of fuel

! CAUTION

ULTRA LOW SULFUR DIESEL FUEL ONLY

- The ASTM(American Society for Testing and Matenals) requires the use of fuel with a sulfur content of 15ppm or less.
- Carefully prevent contaminats and water from entering the storage tank and fuel tank and tighten the filler cap securely.
- When you clean the fuel tank, discharge deposits from the drain plug at the bottom of fuel tank.

343-977-95010

343-977-95010-0

(46) No fire

USE OF FIRE STRICTLY PROHIBITED

343-968-75100

343-968-75100-0

(47) Replacing filter element and hydraulic oil

! CAUTION

Always replace the filter element and hydraulic oil within replacement period designated in operation manual. Failure to make replacements may lead to defects in hydraulic pump or other hydraulic devices (crane operation, steering etc.) and result in serious injury.

343-975-21010

343-975-21010-0

GR-750XL-2_OM2(U)-17E

(50) Caution in travel

PRECAUTIONS FOR TRAVELING

- Before starting to travel, do the followings:
 - Position rear wheels straight, and check STEER lamp for extinction.
 - Return BEAM/JACK select switch and EXT./RET. switch on outrigger control panel to N.
 - Insert slewing lock pin.
- When starting engine, set gear shift lever to N.
- Max. speed in mph:
 - Hi range: 1st--5.5(9km/h) 2nd--11.6(19km/h) 3rd--22.0(36km/h) Reverse--3.9(6km/h)
 - Lo range: 1st-1.6(3km/h) 2nd--3.2(5km/h) 3rd--6.2(10km/h) Reverse-1.6(3km/h)
- Never turn on the PARKING BRAKE switch to PARK during traveling.
- Stop vehicle completely to change steering mode and drive wheels.
- Stop vehicle completely with braking to position gear shift lever from forward to backward or opposite.
- Never stop engine during traveling. When engine stops during traveling, stop vehicle in a safe place immediately. If travel continues with engine stopped, following unfavorable conditions occur.
 - Since no air is supplied, braking effect decreases.
 - Power steering becomes ineffective, and steering wheel becomes extremely heavy.
 Restart engine after vehicle is stopped. If engine does not start after attempting several times, do not fail to repair it.
- Don't keep gear shift lever to neutral position under the condition of road traveling.
- Use 4-wheel drive only when the crane travels on a slippery road such as a rough or snow-covered road. Since 4-wheel drive places the drive system more load than 2-wheel drive, if the crane travels on an ordinary road using 4-wheel drive, the drive system can be damaged.
- Tire should be inflated to correct air pressure.

To maintain the function and service life of the tires, travel according to the following scheme for continuous travel.

Max. average speed		Traveling cycle	19mph(30km/h)		22.0mph(36km/h)	
Tires	Air pressure		Traveling	Cooling	Traveling	Cooling
29.5-25-22PR (BRIDGESTONE VL2A E-3A) (TOYO TIRE G62 E-3)	50psi. (350kPa)	100°F(38°C)	180min.	210min.	60min.	210min.
			122°F(50°C)	60min.	270min.	40min.
29.5-25-28PR E-3	47psi. (330kPa)	100°F(38°C)	120min.	120min.	60min.	150min.
			122°F(50°C)			

343-979-01030

343-979-01030-4

(51) Limit of rated lifting capacity

⚠ CAUTION

85% of tipping load

Rated lifting capacities of this machine do not exceed 85% of the tipping load on outriggers fully extended as determined by SAE J765-Crane Stability Test Code.

343-982-61010-1

343-982-61010-1

(53) Bleeding hydraulic pump

⚠ CAUTION

- After replacing oil or hydraulic pump, do not fail to air-bleed the hydraulic pump. Otherwise the pump may get seized, causing a serious trouble.
- Confirm oil volume while the machine is in traveling style.

TADANO HYDRAULIC OIL LL

370-022-19500

370-022-19500-0

(52) Emergency transmission operation

(For Serial No.548457 or later)

CAUTION

THE MANUAL LOCK DEVICE OF SOLENOID VALVE IS FOR MOVING THE VEHICLE AT THE EMERGENCY. DO NOT TOUCH IT EXCEPT THE EMERGENCY. PRIOR TO USE THIS DEVICE, PLEASE CARRY OUT THE FOLLOWING ACTIONS TO SECURE THE SAFETY.

- STOP THE ENGINE
- FIX THE TIRES WITH THE RATCHET
- TURN ON THE HAZARD LAMP, OR TO PREVENT THE REAR-END COLLISION FROM THE FOLLOWING VEHICLES WITH THE USE OF EMERGENCY SIGNAL IMPLEMENTS
- THERE IS THE CASE THAT THE TRANSMISSION GETS VERY HOT. PLEASE BE CAREFUL NOT TO GET BURNED AT THE TIME OF OPERATION.
- IN CASE THAT THE SOLENOID VALVE IS MANUALLY LOCKED, IT STARTS TO MOVE SIMULTANEOUSLY WHEN THE ENGINE STARTS. THEREFORE, PLEASE PULL THE PARKING BRAKE AT FIRST WITHOUT FAIL AND THEN START THE ENGINE AFTER STEPPING ON THE BRAKE PEDAL. PLEASE STOP PROMPTLY THE ENGINE AFTER THE MOVE AND RETURN THE LOCK BOLT ON THE SOLENOID VALVE TO THE ORIGINAL POSITION.

OPERATION METHOD

- PLEASE CHANGE FIRST THE SHIFT REVER N POSITION AND PULL THE PARKING BRAKE AND THEN STOP THE ENGINE.
- IN THE TRANSMISSION THERE IS A PIN AT THE TIP OF THE SOLENOID VALVE. PLEASE REMOVE THE PIN OF THE SOLENOID OF THE SIDE TO BE USED.
- PLEASE LOOSEN THE LOCK NUT OF THE MANUAL LOCK DEVICE EXISTING THE SIDE OF SOLENOID AND TURN MANUALLY THE HEXAGON BOLT CLOCKWISE AND TIGHTEN FIRMLY. THE SOLENOID VALVE WILL BE AT ENERGIZED POSITION. PLEASE SELECT ONE OF SUITABLE SHIFT POSITION WITH THE COMBINATION OF SOLENOID VALVE.

FORWARD POSITION	F2 SOLENOID
REVERSE POSITION	R SOLENOID

PLEASE START THE ENGINE AFTER STEPPING ON THE FOOT BRAKE.

PLEASE START SLOWLY.

363-507-00050
363-507-00050-0

(For up to Serial No.548456)

CAUTION

DO NOT TOUCH THE EMERGENCY LOCK BOLTS OF SOLENOID VALVE. AT EMERGENCY, LOOSEN THE LOCK NUTS ON THE SIDE OF SOLENOID VALVE. AND TURN THE HEXAGON BOLTS CLOCKWISE MANUALLY AND TIGHTEN FIRMLY. THE SOLENOID WILL BE AT ENERGIZED POSITION. SELECT ONE OF SUITABLE SHIFT POSITION.

FORWARD POSITION F2 SOLENOID

REVERSE POSITION R SOLENOID

前進 F2 用ソレノイドを操作

後進 R 用ソレノイドを操作

363-507-00040
363-507-00040-0

TRAVELING

Before Traveling

Check of Traveling Configuration

⚠ DANGER

Travel on roads only in the specified traveling configuration. Otherwise, the swaying hook block and boom, and an extended outrigger beam can cause a serious accident. Be sure to set the machine into the traveling configuration before traveling.

Before traveling on roads, set the machine to the correct traveling configuration.

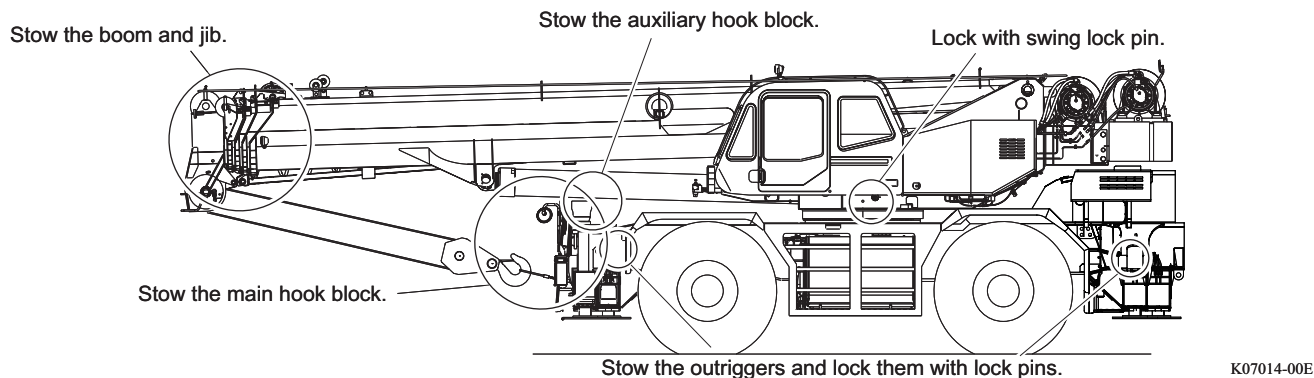

Status of the Traveling Controls

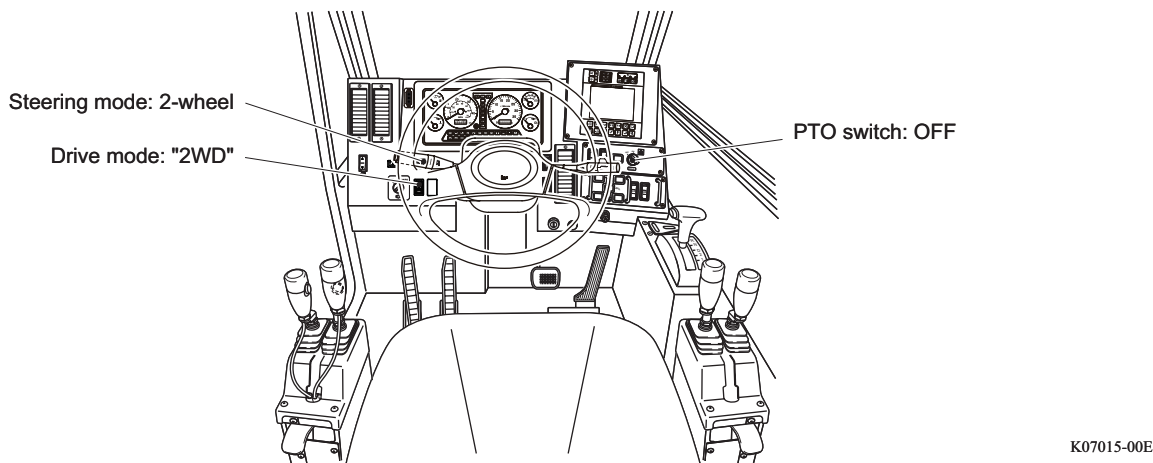

Inspection before Traveling

Refer to the "Inspection before Traveling" (page 332) when you perform the inspections.

Entering the Cab

The items below are explained here.

- Opening/Closing the Door
- Opening/Closing the Window
- Adjustment of the Seat
- Adjustment of the Steering Wheel
- Adjustment of the Mirrors
- Fastening/Unfastening of the Seat Belt
- Adjustment of the Control Lever Stand
- Sunshade

Opening/Closing the Door

NOTICE

**A door that is not closed properly can open unexpectedly during traveling.
Securely close the door before traveling.**

Locking and Unlocking from Outside of the Vehicle

Insert the key, and turn it clockwise to lock and counterclockwise to unlock the door.

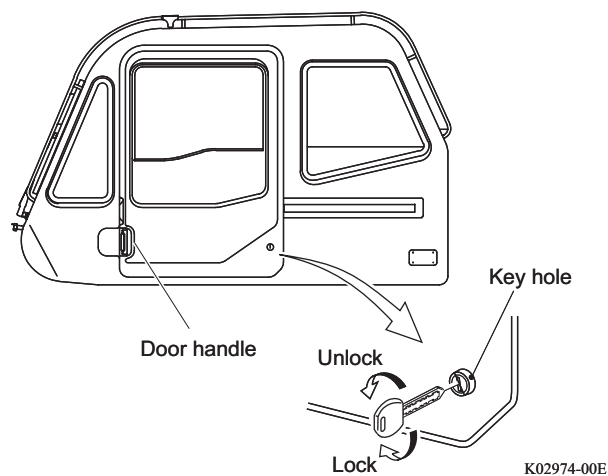

Opening/Closing the Door from Outside of the Vehicle

CAUTION

Do not hold the rear end of the door when you close it. Your fingers may be pinched. Hold the door handle to close the door.

Pull the door handle in the sliding direction of the door to open/close the door.

Opening/Closing the Door from Inside of the Vehicle

Pull the door lever in the sliding direction of the door to open/close the door.

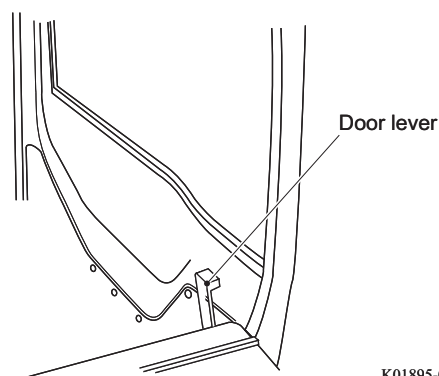

Locking the Door When It Is Opened

WARNING

Do not operate the crane with the door opened and unlocked. Otherwise, the door can close during the swing operation and your body can get caught.

Use this lock when you operate the crane with the door opened.

Fully open the door and tilt the lock lever forward to lock the door, and tilt the lever rearward to unlock the door.

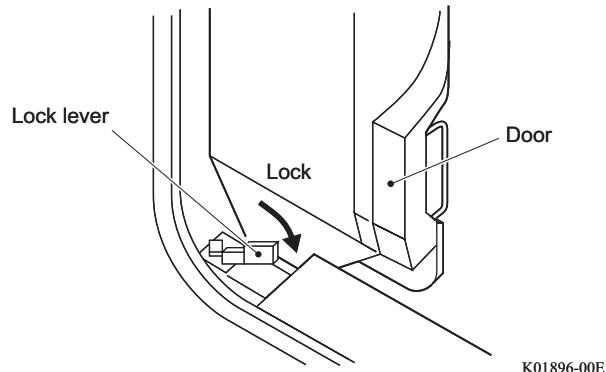

Opening/Closing the Window

Opening/Closing the Door Window

⚠ WARNING

Do not close a window with your hand or head out of the window. Otherwise, your hand or head can get caught.

NOTICE

When you leave the cab, be sure to close the window(s). If the control device in the cab gets wet, it may cause a failure.

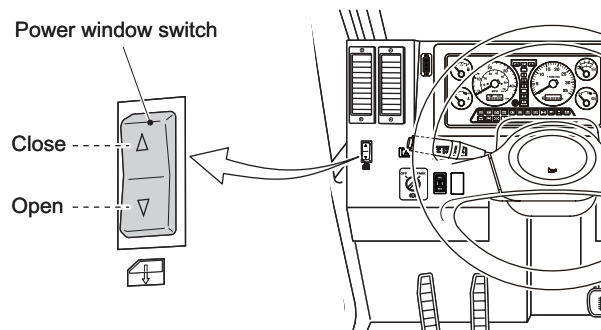

K07016-00E

Open/close the window with the power window switch.

While the starter switch is "ON", and the door is closed, you can open or close the window.

Power Window Close Switch

You can close the window from the outside when the door is closed.

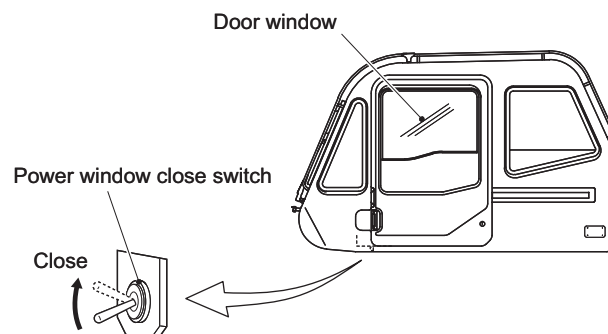

K02975-00E

Adjustment of the Seat

⚠ WARNING

- Do not adjust the seat during driving or the crane operation. Otherwise, erroneous operation during adjustment can cause an accident.
- If you sit on an unsecured seat, the seat can move and you can cause an accident. After you adjust seat position, shake the seat back and forth slightly to make sure that it is secured.

Adjust the seat to a position where you can press the pedals down far enough and operate all the devices easily when you sit on the seat.

Height Adjustment

Pull the height adjustment lever to adjust the height of the seat.

Slide Adjustment

Move the seat back and forth while you pull the slide adjustment lever.

Reclining Adjustment

Move the backrest back and forth while you pull the reclining adjustment lever.

Armrest Adjustment

Adjust the angle of the armrest while you push the armrest adjustment button.

Headrest Height Adjustment

Push the headrest height adjustment knob and adjust the height of the headrest.

Adjust the height so that the center of the headrest is at the height of your ears.

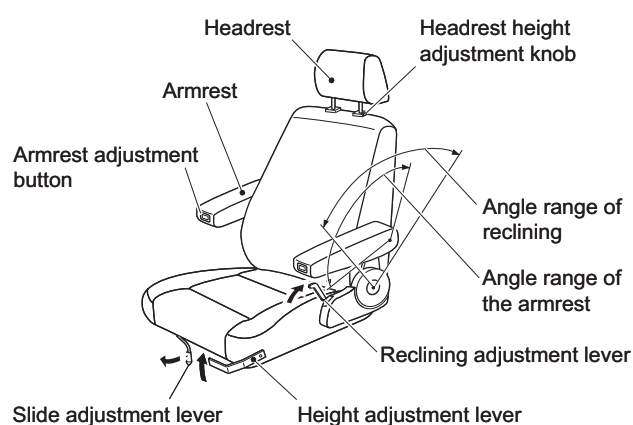

K01427-00E

Adjustment of the Steering Wheel

⚠ WARNING

- Do not adjust the steering wheel while you travel. Otherwise, erroneous operation during adjustment can cause an accident.
- If a steering wheel is not secured firmly, its position can change suddenly during traveling. It can cause an accident. Check that the steering wheel is secured firmly.

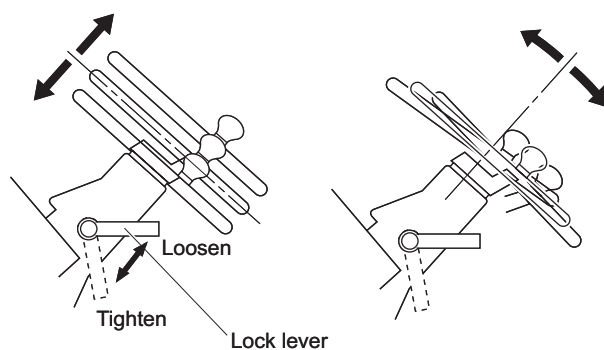

G13007-00E

You can adjust the height and angle of the steering wheel.

Raise the lock lever and adjust the steering wheel to the optimum position, and lower the lock lever to secure the steering wheel.

Adjustment of the Mirrors

⚠ WARNING

Adjust the mirrors so that you can have good view of the sides, rear, and front of the machine. If mirrors are not adjusted correctly, it can cause an accident.

Adjust mirrors so you can have good view of the sides, rear, and front of the machine.

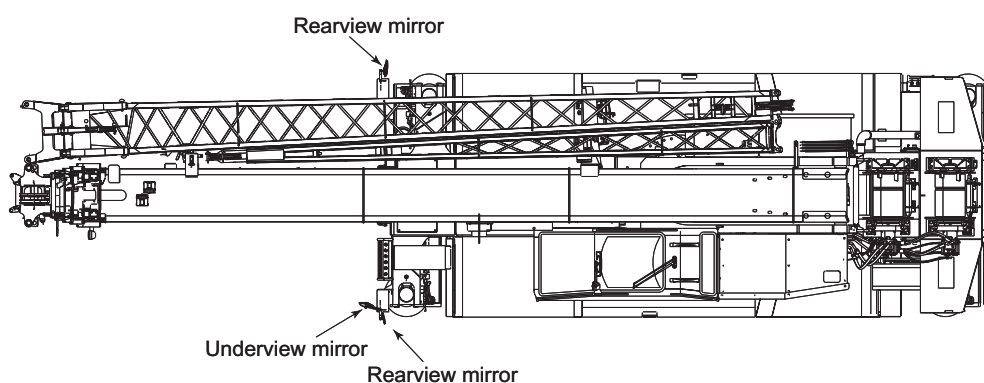

K07017-00E

If you cannot see the road surface due to the boom while traveling in a work site, set the boom in the state below, and refer to the section "On-rubber Creep Operation" (page 223).

- Boom length: 36.1 ft. (11 m) (fully retracted)
- Boom angle: 40° or under
- Swing angle: Front (the front position symbol on the load moment indicator lights up)

Do not travel in a work site with other than the state of the crane explained above.

Fastening/Unfastening of the Seat Belt

Before start of traveling, wear the seat belt for safety.

1. Make sure that the belt is not twisted, and then put the tongue plate into the buckle until a "click" sound is heard.

⚠ WARNING

Wear the seat belt across the hipbones. If it is off the position, strong pressure can be inflicted on your abdomen during collision.

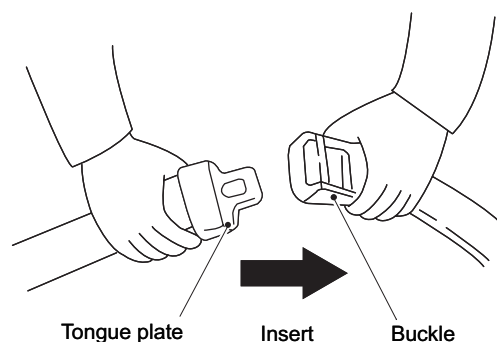

G13010-00E

2. Adjust the belt so that there is no looseness.
3. Press the button on the buckle to unfasten.

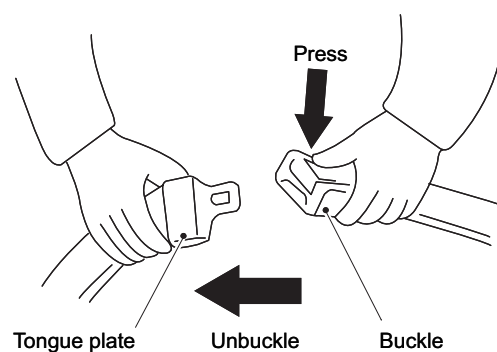

G13011-00E

Adjustment of the Control Lever Stand

⚠ WARNING

- If you touch the control lever when you enter or exit the cab, the crane can move. It can cause an accident.
When you complete a crane operation, set the control lever stand on the left to the stowage position.
- Stow the armrest before you stow the control lever stand.
If the control lever touches the armrest, the crane can move and it can cause an accident.

You can adjust the position of the control lever stand in 3 stages.

Before you enter or exit the cab, or when you complete crane operation, set the control lever stand on the left to the stowing position.

While pulling the unlock lever, adjust the position of the control lever stand.

- ☞ If you set the control lever stand to the stowing position while the swing free/lock selector switch is "ON", the swing brake is activated. When you return the control lever stand to the position for crane operation, the swing brake is cancelled.

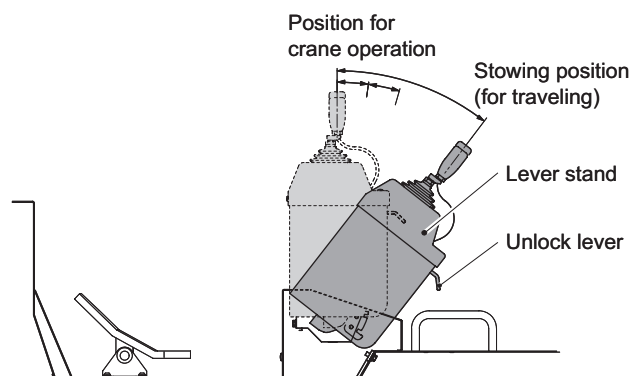

K03515-00E

Sunshade

Use the sunshade when the sun is dazzling.

To use it, hold the tab at the end of the sunshade, and pull it forward. Then hook the ends to the catch.

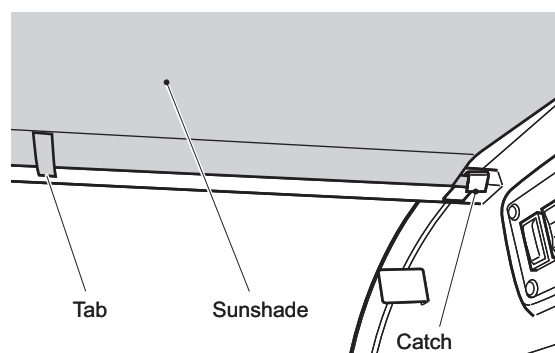

K01901-00E

Reading the Instrument Panel

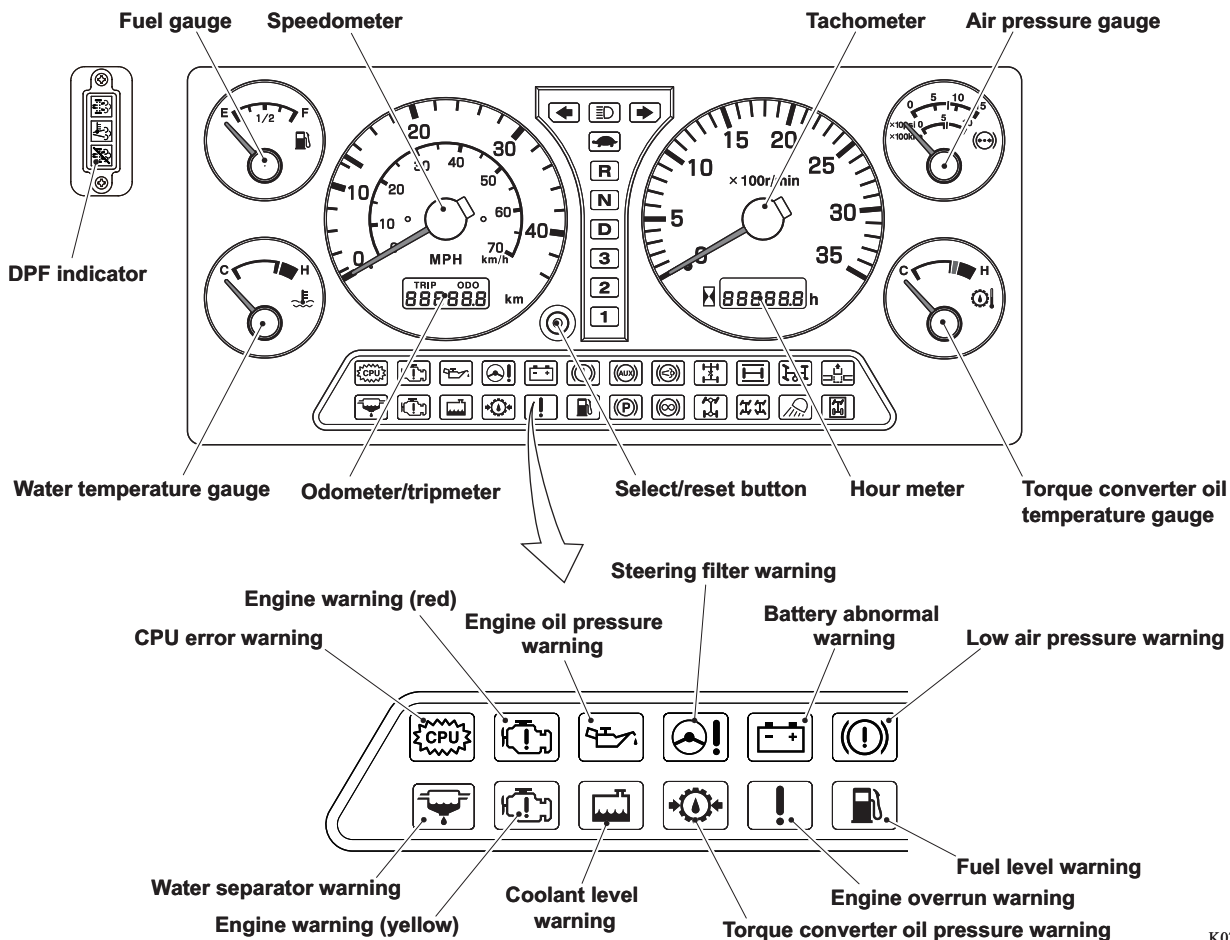

K07018-00E

Meters and Gauges

Fuel Gauge

Shows the remaining fuel amount.

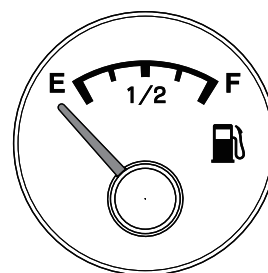

K00413-000

Water Temperature Gauge

NOTICE

When the pointer is in the red zone, the engine is overheated. Stop the crane at a safe area, and idle the engine to cool down the coolant. Refer to "If Overheated" (page 429) for details.

Shows the temperature of engine coolant.
While the pointer is in the white zone, the coolant temperature is normal.

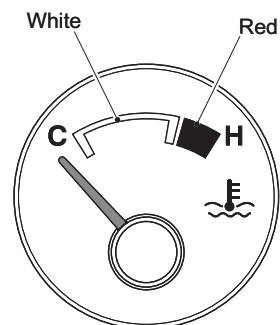

K00412-01E

Speedometer

Shows the traveling speed of the vehicle in mph and km/h.

 When the vehicle speed is excessively high, the alarm buzzer sounds.

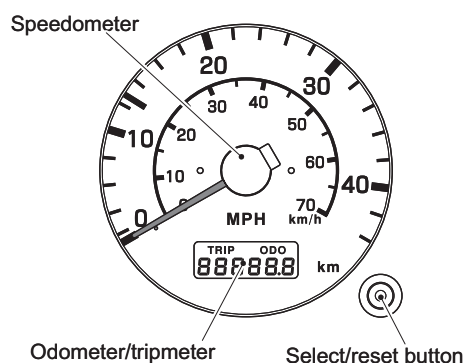

K01217-00E

Odometer/Tripmeter (Total/sectional distance meter)

Shows the total travel distance or sectional distance in km. When the sectional distance is shown, the number at the right end means the unit of 100 m.

Odometer/Tripmeter Change Button

Changes the meter display between the odometer and trip meter. In order to reset the tripmeter, push the button and hold it for one second or longer while the tripmeter display is selected.

Tachometer

Shows engine speed per minute.

Hour Meter

Shows engine operating hours.

 The hour meter shows the total time of engine operation when engine speed exceeds 500 min⁻¹.

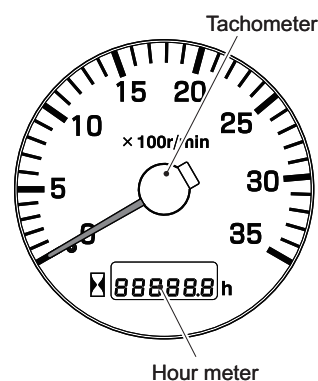

K00411-00E

Air Pressure Gauge

⚠ WARNING

- If the pointer of the air pressure gauge is at or below the red mark (lower limit of the specified pressure) during traveling, there is a risk of a serious accident. Immediately stop the crane at a safe area. Do not travel in this state.
- Do not start traveling if the pointer of the air pressure gauge is at or below the red mark (lower limit of the specified pressure). Otherwise, the braking force of the foot brake decreases and the parking brake drags. They can cause an accident. Start traveling only after the air pressure reaches the specified pressure.

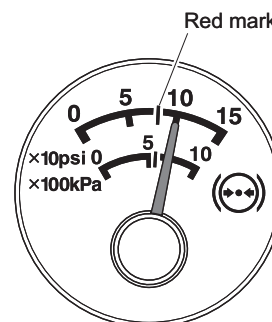

K01218-00E

Shows the air pressure in the air tank.

Torque Converter Oil Temperature Gauge

NOTICE

The pointer in the red zone means that the oil temperature is abnormally high. Stop the crane at a safe area, and idle the engine to cool down the oil.

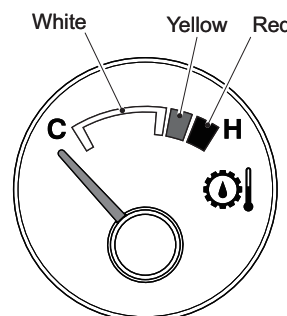

K00414-00E

This gauge indicates the temperature of the torque converter oil.

While the pointer is in the white zone, the oil temperature is normal.

DPF (Diesel Particulate Filter) Indicator

DPF indicator shows the status of the diesel particulate filter.



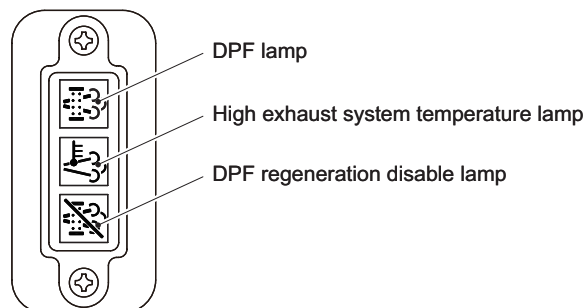

NOTICE

**If the high exhaust system temperature lamp often lights up, the engine has a failure.
Contact your nearest TADANO distributor or dealer.**

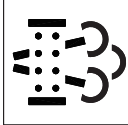

K03956-00E

DPF indicator and meanings

Indicator	Meanings of DPF indication	Remedy
 DPF lamp (orange) K03957-00E	Lit The particulate matter is accumulated in the DPF.	Early manual regeneration is required.
	Flashing  Engine warning (yellow) K03971-00E A large amount of particulate matter is accumulated in the DPF, and the filter is clogged. According to the severity of the clog, the warning lamp below flashes. The engine torque is cut by 40%.	Immediate manual regeneration is required.
 Engine warning (red) K03972-00E	The engine torque is cut by 40% and the maximum engine speed is limited to 1800 min ⁻¹ {rpm}.	The manual regeneration cannot be performed. Contact your nearest TADANO distributor or dealer.
 High exhaust system temperature lamp K03958-00E	The DPF manual regeneration is activated.	Wait till the manual regeneration is completed.
	 Approx. 20 seconds after the exhaust gas temperature reaches approx.1472°F (approx. 800°C), the engine warning lamp (red) lights up and the engine stops.	The exhaust gas temperature is over 1247°F (675°C).







GR-750XL-2_OM2(U)-17E

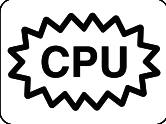
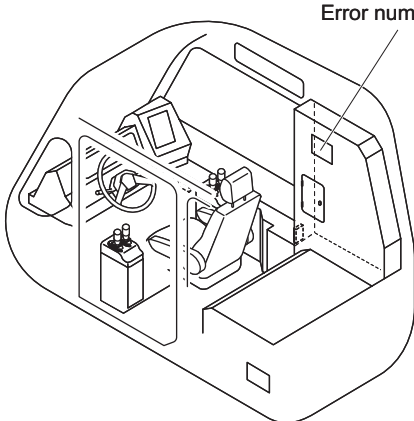
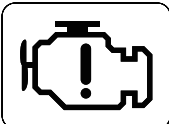
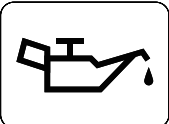

Indicator	Meanings of DPF indication	Remedy
 <p data-bbox="204 439 363 483">DPF regeneration disable lamp</p> <p data-bbox="309 495 399 517">K03959-00E</p>	<p data-bbox="432 264 1007 371">DPF regeneration is disabled. While the DPF regeneration disable warning is lit, regeneration is disabled.</p> <p data-bbox="432 421 1007 533">☞ To interrupt DPF regeneration, refer to "To Interrupt DPF Regeneration" (page 424)</p>	<p data-bbox="1010 342 1465 416">Remove the cause of the interruption to enable DPF regeneration.</p>

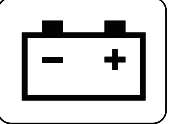
Warning Lamp

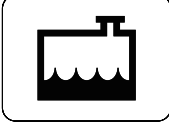
When any warning lamp lights up, immediately perform a remedy.
After the remedy, the warning lamp will go out.

Warning lamp	Meaning of indication	Remedy
 <p>CPU error warning K00357-00E</p>	<p>An abnormality has occurred in the computer system. (At the same time, an error number is indicated on the error number display.)</p>  <p>Error number display K03087-00E</p>	<p>Park the vehicle at a safe place or stop the crane operation. Set the crane into a safe posture. Change the starter switch to "OFF" and wait for 30 seconds or more, and then restart the engine. If the indication does not go out, make a note of the error number, and contact your nearest TADANO distributor or dealer.</p>
 <p>Engine warning K00358-00E</p>	<p>An abnormality has occurred in the engine control system. (At the same time, an error number is indicated on the error number display.)</p>	<p>Stop the vehicle at a safe place, or stop crane operation and stow the crane. Change the starter switch to "OFF" and wait for 30 seconds or more, and then restart the engine. If the indication does not go out, make a note of the error number, and contact your nearest TADANO distributor or dealer.</p>
	<p>The fuel filter contains water more than the specified amount.</p>	<p>Drain the fuel filter.</p>
 <p>Engine oil pressure warning K00359-00E</p>	<p>Engine oil pressure has dropped. (Normally, this appears when the starter switch is turned to "ON", and disappears when the engine is started.)</p>	<p>Early manual regeneration is required. Stop the vehicle at a safe area and stop the engine. Examine the engine oil level. If this warning lamp is on when the oil level is right or remains on even after oil is added to the specified level, contact your nearest TADANO distributor or dealer.</p>

Warning lamp	Meaning of indication	Remedy
 <p>Steering pump warning K06751-00E</p>	<p>The hydraulic pressure of the steering pump is low.</p> <p> Applicable only for the model equipped with the emergency steering pump (option).</p> <p>The steering filter is clogged.</p>	<p>Stop the vehicle at a safe area and stop the engine.</p> <p>Contact your nearest TADANO distributor or dealer.</p> <p>Replace the steering filter.</p>
 <p>Battery abnormal warning K00361-00E</p>	<p>An abnormality has occurred in the battery charging system.</p> <p>(Normally, this appears when the starter switch is turned to "ON", and disappears when the engine is started.)</p>	<p>Stop the vehicle at a safe area and stop the engine.</p> <p>Contact your nearest TADANO distributor or dealer.</p>
 <p>Low air pressure warning K00362-00E</p>	<p>Air pressure is low.</p> <p>(At the same time, the alarm buzzer sounds. When the parking brake switch is set to "PARK", the buzzer sound stops.)</p> <p>(Run the engine with the machine stopped. When the warning goes out, the air pressure is normal.)</p>	<p>Park the machine in a safe place.</p> <p>If the lamp remains lit, contact your nearest TADANO distributor or dealer.</p>
 <p>Coolant level warning K00364-00E</p>	<p>The coolant level is low.</p>	<p>Top up the coolant in the coolant reservoir.</p>
 <p>Water separator warning K00363-00E</p>	<p>The fuel filter contains water more than the specified amount.</p>	<p>Drain water from the fuel filter and the water separator.</p>
 <p>Torque converter oil pressure warning K00365-00E</p>	<p>Oil pressure in torque converter is low.</p> <p>(At the same time, the alarm buzzer sounds. When the parking brake switch is set to "PARK", the buzzer sound stops.)</p> <p>(Normally, this appears when the starter switch is turned to "ON", and disappears when the engine is started.)</p>	<p>Stop the vehicle at a safe area and stop the engine.</p> <p>Check the torque converter oil level. If this warning does not go out when the oil level is normal or even after the oil is added to the specified level, contact your nearest TADANO distributor or dealer.</p>

Warning lamp	Meaning of indication	Remedy
 <p data-bbox="161 517 331 539"><u>Engine overrun warning</u></p> <p data-bbox="272 551 357 573">K00366-00E</p>	<p data-bbox="376 264 919 331">Engine speed is beyond the permitted limit. (At the same time, the alarm buzzer sounds.)</p> <p data-bbox="376 342 962 533">  Also lights up while the engine is being preheated during engine startup. (Engine preheating is automatically started depending on the engine temperature when the starter switch is turned to "ON".) </p> <p data-bbox="376 544 906 566">Lights up while counterweights are removed.</p>	<p data-bbox="999 264 1382 331">Decrease the vehicle speed and engine speed.</p> <p data-bbox="999 544 1449 611">Install counterweights while the crane is in operation or traveling.</p>
 <p data-bbox="185 842 323 864"><u>Fuel level warning</u></p> <p data-bbox="272 875 357 898">K00367-00E</p>	<p data-bbox="376 667 967 734">Remaining fuel is approximately 13.2 gal (50 L) or less.</p>	<p data-bbox="999 667 1238 689">Refuel the machine.</p>

Starting and Stopping the Engine

NOTICE

If accessories are used for a long time while the engine is stopped and the switch is turned to "ON" or "BATTERY", the battery will be exhausted.

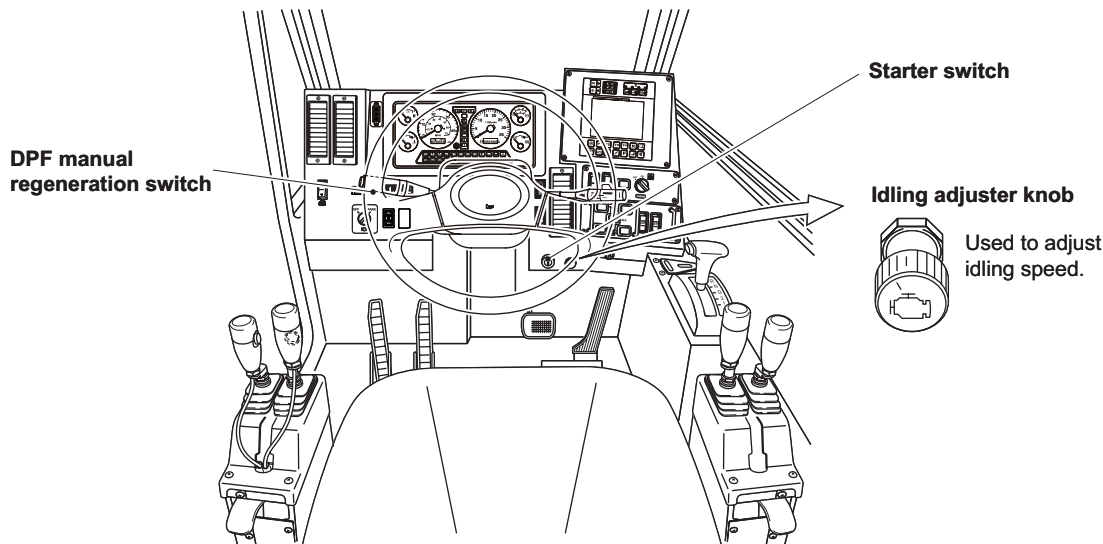

K07019-00E

Starter Switch	Meanings of each switch position	
OFF	Position where the engine is off. The key can be inserted and removed in this position.	<p>The diagram shows a key with four positions: (OFF) at the top, (BATTERY) with a lightning bolt symbol, (ON) with a battery symbol, and (START) with a key symbol.</p>
BATTERY	Position where accessories can be used without starting the engine.	
ON	Position where the engine is running.	
START	Position where the engine can be started. When the engine is started, release the key. The key returns to "ON" automatically.	

K02680-01E

Idling Adjuster Knob

You can manually adjust the idling speed. When the knob is released, it automatically returns to the central position.

Turn in "FAST" direction: Idling speed increases.

Turn in "SLOW" direction: Idling speed decreases.

☞ One click changes the engine speed by 50 min^{-1} {rpm}. The maximum engine speed with this knob is 1,200 min^{-1} {rpm}.

☞ The manually adjusted speed is canceled when the engine is stopped.

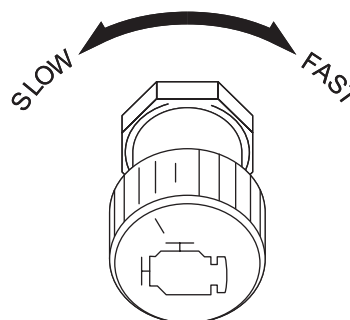

K07020-00E

How to Start the Engine

⚠ WARNING

- Do not start the engine from outside the vehicle (through the window opening, etc.). It may cause an accident. Sit on the seat in the cab to start the engine.
- Do not leave the engine running for a long time where air flow is poor. It can cause carbon monoxide poisoning by the exhaust gas.

1. Before you start the engine, set the levers and switches in the position as shown below.

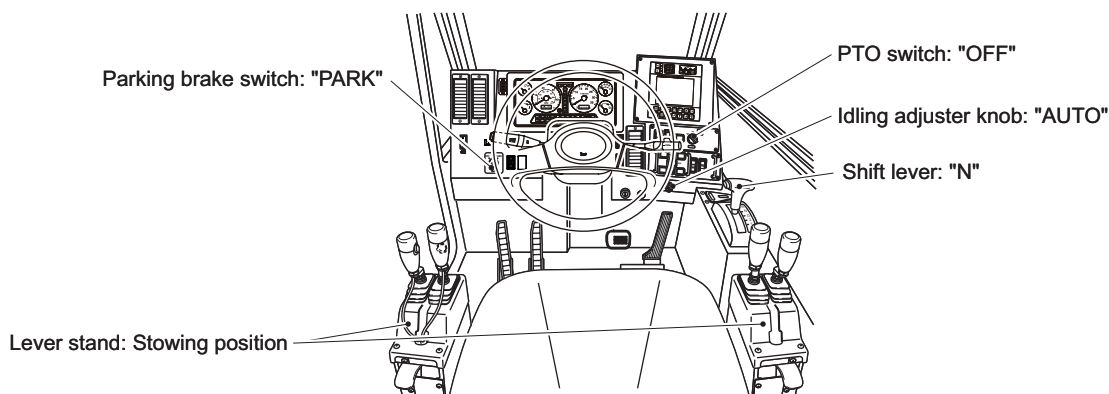

K07021-00E

2. Turn the starter switch to "ON", and make sure that the indicators on the instrument panel light up for 1 to 2 seconds.

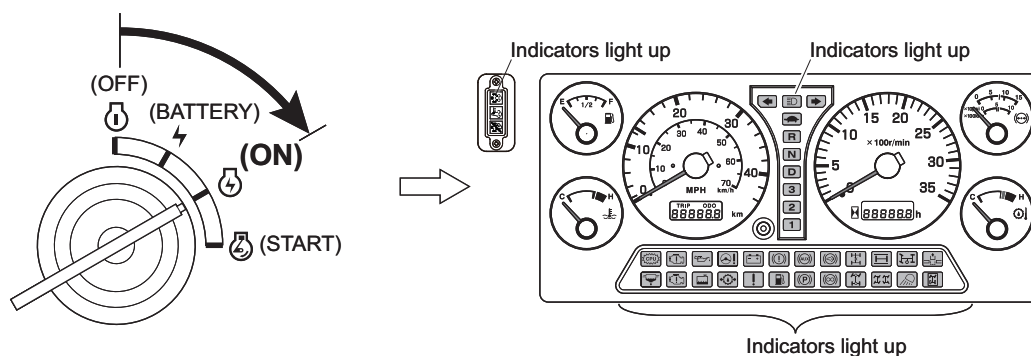

K07022-00E

☞ When the engine temperature is low, the engine preheating is automatically started. The engine overrun warning stays lit. When the preheating is completed, it will go out.

3. Depress the brake pedal.
4. Turn the starter switch to "START". When the engine is started, immediately release the key.

NOTICE

- Do not keep running the starter motor for 15 seconds or more. Otherwise, the motor may burn out. If the engine does not start, return the starter switch to "OFF" and wait for 30 seconds or more, and then restart the engine.
- Make sure that there is no abnormality with the color of exhaust gas, sound, and vibration after the engine is started. If there is any abnormality, contact a TADANO distributor or dealer.

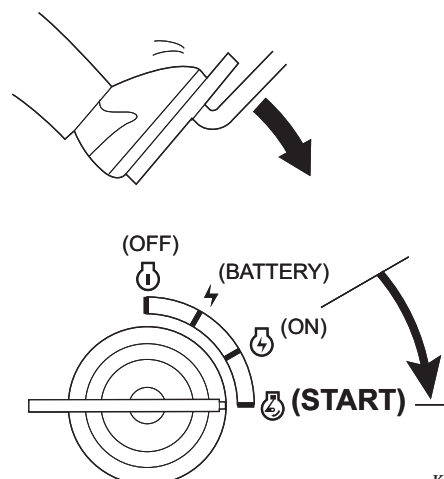

K02683-000

How to Stop the Engine

1. Set the levers and switches in the position shown below.

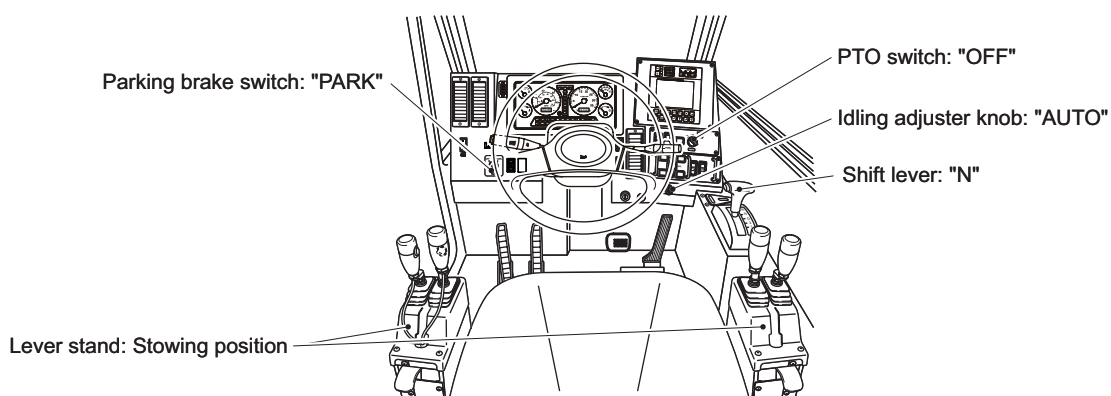

K07021-00E

2. Perform idling run for approximately 3 minutes to cool the engine.
3. Turn the starter switch to "OFF".
4. After the engine stops, pull out the key from the starter switch.

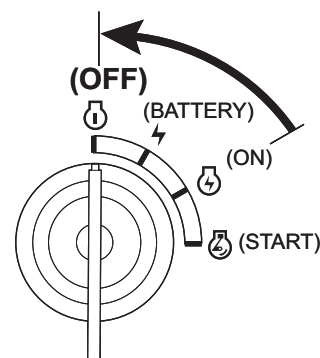

K02684-000

When the engine does not stop, refer to "If the Engine Does Not Stop" (page 428).

DPF regeneration

CAUTION

Make sure that the DPF exhaust area is clear of materials that ignite and burn. The temperature of the exhaust reaches 1112 F° (600 °C) or over during the DPF regeneration. The materials that ignite and burn around the exhaust area may cause fire.

When the DPF lamp lights up or flashes, manual regeneration is required.

The DPF regeneration can burn the particulate matter in the filter and clean the clogged filter.

1. Start the engine.
2. Set the levers and switches in the position shown below.

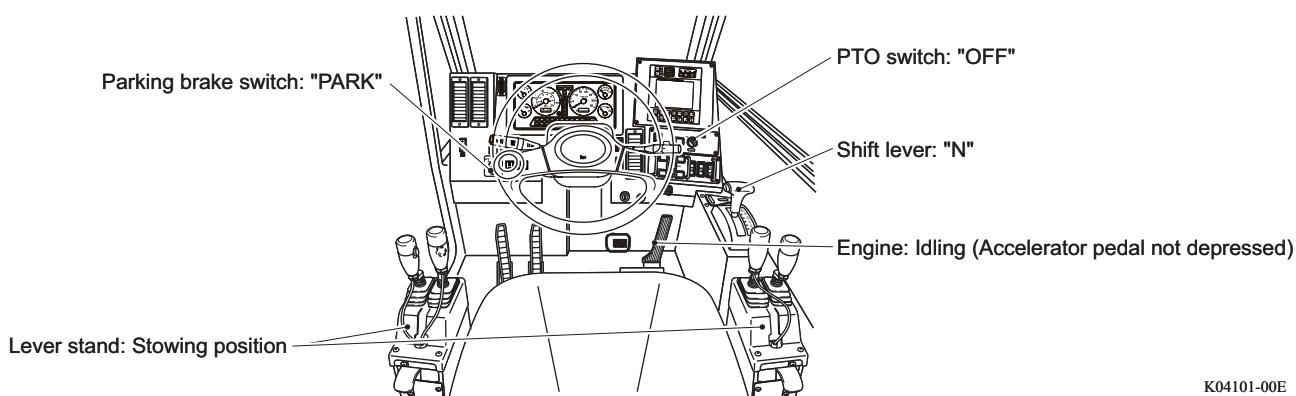

K04101-00E

3. Push the DPF manual regeneration switch for 5 seconds.
 - The DPF manual regeneration is commenced.
 - During the DPF regeneration, the high exhaust system temperature lamp light up and DPF lamp goes out.

- ☞ The engine speed increases from 700 min^{-1} {rpm} to 1,000 min^{-1} {rpm}.
- ☞ The regeneration takes approx. 20 minutes.
- ☞ When you cancel the regeneration, refer to "To Interrupt DPF Regeneration" (page 424).
- ☞ The DPF regeneration is canceled if the engine is accelerated during the DPF regeneration.
If this happens, stop the acceleration and then resume the regeneration.

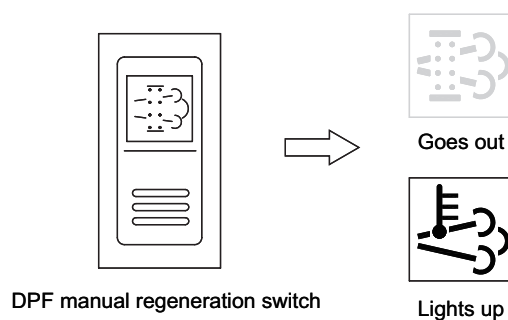

K03963-00E

4. After DPF regeneration is completed, the DPF lamp and the high exhaust system temperature lamp go out.

 The engine speed returns to the idling speed.

Transmission Operation

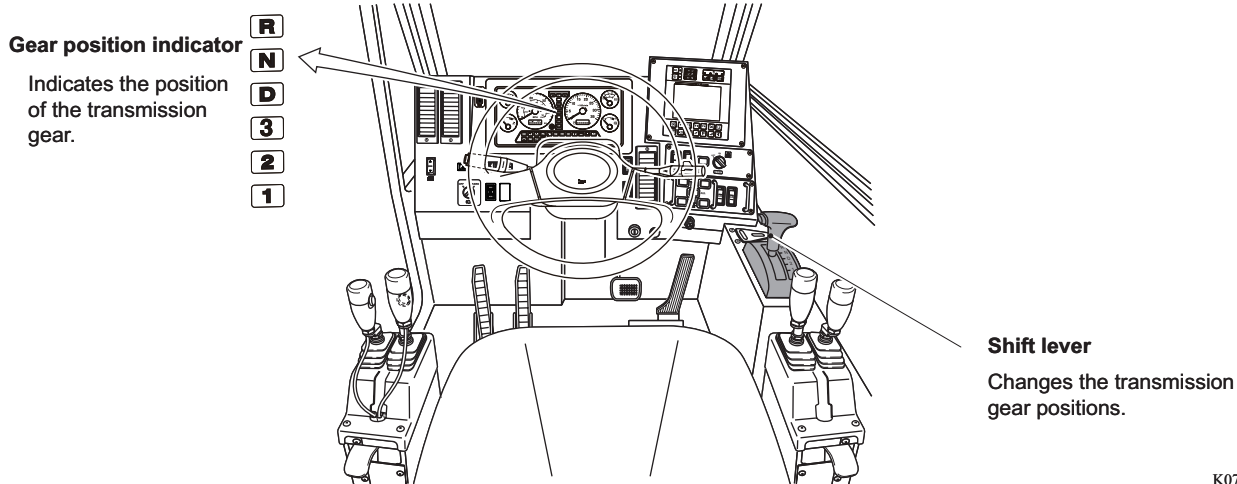

K07058-00E

Positions and Functions of the Shift Lever

⚠ WARNING

Carry out operations of ↑ ↓ without pushing the shift lever button. If you always push the shift lever button to operate the lever, you may accidentally change the lever to "R". This can cause an accident.

Shift lever button

- R (Reverse)** Reverse
The gear is fixed to reverse.
- N (Neutral)** Neutral
The engine drive power is not transmitted. This is a position for engine start, parking, and crane operation.
- D (Drive)** Drive
Normal traveling
The gear is automatically changed from the first through third gear depending on the vehicle speed. The gear is fixed to the third gear in the driving mode of L/4D (4WD low speed traveling).
- 2 (Second)** Second
Traveling on slope
Use this when ascending a long slope, or using engine braking to descend a slope. The gear is fixed to the second gear.
- 1 (Low)** Low
Traveling on slope
Use this when ascending a steep slope, or requiring a strong engine brake force. The gear is fixed to the first gear.

↑ ↓ The lever can be moved without pressing the shift lever button.

↑ ↓ The lever can be moved only while the shift lever button is pressed.

K03167-00E

GR-750XL-2_OM2(U)-17E

Shift Lever Operation

Shift Lever Operation at Starting

⚠ WARNING

- Do not operate the shift lever while pressing the accelerator pedal.
The vehicle can start suddenly and cause an accident.
- When the shift lever is shifted to "D", "1", "2", or "R", the vehicle can start moving by creeping effect, and it can cause an accident.
Before you operate the shift lever, press the brake pedal to prevent movement of the vehicle.

 If you leave the parking brake applied and operate the shift lever, the alarm buzzer sounds.

1. Press and hold the brake pedal.

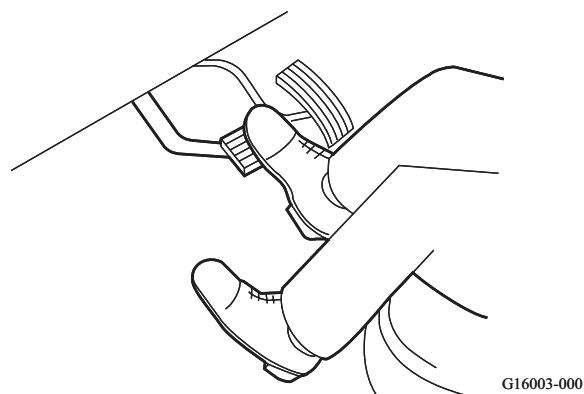

2. Set the parking brake switch to "OFF".
 - The brake warning lamp goes out.

3. Operate the shift lever.

4. After you check around the vehicle, release the brake pedal, and slowly press the accelerator pedal to start.

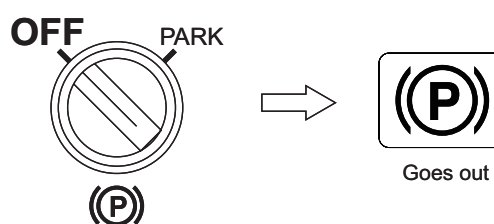

K01226-00E

Gear Position Indicator

While the gear position is "D" (automatic drive), the gear position "D" and the current gear position are shown by the illumination of the lamps.

Gear position	First gear	Second gear	Third gear
Lighting state of indicator	R N D S 2 1	R N D S 2 1	R N D S 2 1

K02352-00E

Shift Lever Operation during Traveling (Manual Operation)

⚠ WARNING

**Do not drive the machine with the shift lever is in "N".
Otherwise, seizure of the transmission or over-speeding can cause an accident.**

NOTICE

- If the vehicle speed exceeds the specified speed range of the currently selected shift position, the engine can overrun, resulting in engine damage. When the speed is likely to exceed the speed range of the current shift position on a steep downhill, use the intermittent foot brake to decrease the vehicle speed.
- If the shift lever is moved from forward ranges to reverse or vice versa while the vehicle moves, the transmission can be damaged. Operate the shift lever after the vehicle is completely stopped.

When traveling on a slope, use the shift positions of "1", "2", and "D" properly depending on the gradient. Before upshifting, release the accelerator pedal. Before downshifting, decrease the vehicle speed to the speed range of the lower gear position.

 If the shift lever is moved to "2", or "1" while the vehicle speed is not reduced, the gear would not shifted down until the speed reaches the specified speed range of the shift position.

Shift position	2WD, H/4D		L/4D	
	Gear position	Vehicle speed range	Gear position	Vehicle speed range
1	Fixed to 1st	0 to 5.5 mph (0 to 9 km/h)	Fixed to 1st	0 to 1.6 mph (0 to 3 km/h)
2	Fixed to 2nd	0 to 11.6 mph (0 to 19 km/h)	Fixed to 2nd	0 to 3.2 mph (0 to 5 km/h)
D	1st to 3rd	0 to 22.0 mph (0 to 36 km/h)	Fixed to 3rd	0 to 6.2 mph (0 to 10 km/h)
R	Fixed to 2nd	0 to 3.9 mph (0 to 6 km/h)	Fixed to 1st	0 to 1.6 mph (0 to 3 km/h)







(2WD, H/4D and L/4D indicate drive mode.)

GR-750XL-2_OM2(U)-17E

Brake Operation

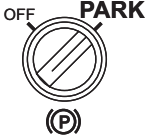
There are 3 types of brakes as shown below.

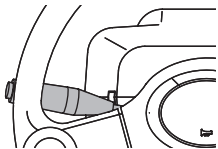
Use an appropriate one depending on the driving situations.

Type of brake		Operating device	State of indicator	Application
Main brake	Foot brake	 Brake pedal		Used to decelerate or stop the vehicle.
Parking brake	Parking brake	 Parking brake switch	Brake warning  Lights up	Used to stop or park the vehicle.
Auxiliary brake	Exhaust brake	 Exhaust brake switch (Combination switch)	Exhaust brake indicator  Lights up	Use this brake as an auxiliary brake to decelerate the vehicle. This increases the effect of engine brake when traveling on a downward slope, etc.

K01227-00E

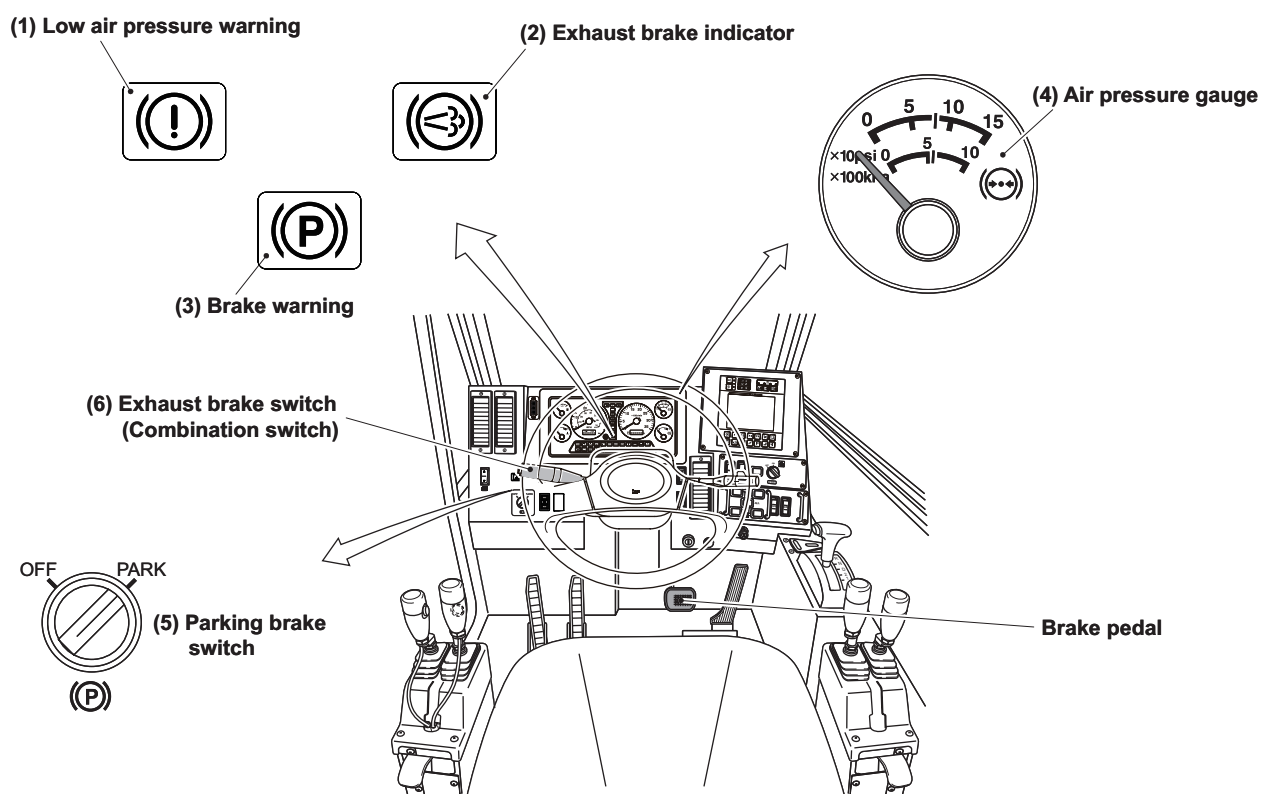

K07023-00E

(1) Low Air Pressure Warning

Lights up when the air pressure is low. Goes out when the air pressure increases.

(2) Exhaust Brake Indicator

Lights up when the exhaust brake is activated, and goes out when the exhaust brake is canceled.

(3) Brake Warning

Lights up when the parking brake is applied. This also lights up when the brake fluid level is low.

(4) Air Pressure Gauge

Shows the air pressure in the air tank.

(5) Parking Brake Switch

When the switch is set to "PARK", the parking brake is applied. When this switch is set to "OFF", the parking brake is released.

(6) Exhaust Brake Switch (Combination Switch)

When the lever is operated downward, the exhaust brake is activated.

⚠ WARNING

- Do not start to travel if the air pressure gauge reading is below the red mark (lower limit of the specified pressure) and the low air pressure warning is lit. Otherwise, the braking force of the foot brake decreases and the parking brake drags, and they can cause an accident. Start traveling after the air pressure becomes the specified value and the low air pressure warning goes out.
- Do not travel with the parking brake applied. Otherwise, a fire or failure can be caused by the overheated parking brake.
- Excessive use of the foot brake overheats the brake system and degrades braking performance, and it may cause an accident. When you drive on a long downward slope, downshift and use the engine brake together with the exhaust brake.
- When the brake warning or the low air pressure warning lights up, or the alarm buzzer sounds during traveling, stop the vehicle at a safe area immediately. Do not travel in this state.

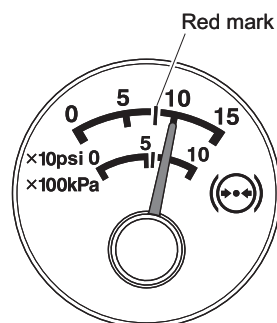

K01342-00E

NOTICE

When you temporarily stop after you travelled on a long downward slope for a traffic signal, etc., apply the parking brake and release the brake pedal. This prevents vapor lock and decreases overheating of the brake device.

Keep in mind to release the foot brake as much as possible to dissipate heat.

-  If you turn the parking brake switch to "OFF" while the air pressure is below the specified pressure, the low air pressure alarm sounds. When the switch is turned to "PARK", the buzzer stops.

Foot Brake Operation

Press the brake pedal with your right foot.
Press the foot brake intermittently to decrease the vehicle speed efficiently in a short time.

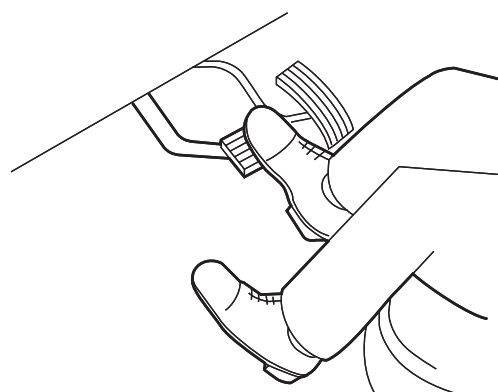

G16003-000

Parking Brake Operation

⚠ WARNING

The parking brake needs approx. one second after the operation until it engages. Do not release the brake pedal until the parking brake engages. The vehicle can move and cause an accident.

NOTICE

- Do not apply the parking brake unless the vehicle is completely stopped. This can damage the parking brake.
- When you park on a slope unavoidably, apply the parking brake and set stoppers to the tires.

☞ If you set the parking brake switch to "PARK" while the shift lever is out of "N", an alarm buzzer sounds to warn you against leaving the parking brake applied. When the switch is turned to "OFF", the buzzer stops.

1. Stop the vehicle.
2. Set the shift lever to "N".
3. Set the parking brake switch to "PARK".
 - The parking brake engages and the brake warning lights up.
4. Slowly release the brake pedal while you examine the engagement of the parking brake.

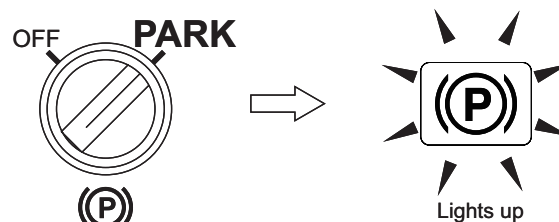

Exhaust Brake Operation

K01229-00E

1. Operate the lever of the exhaust brake switch downward.
 - The exhaust brake indicator lights up.

☞ The exhaust brake does not activate when the shift lever is in "N", or while the vehicle is stopped.

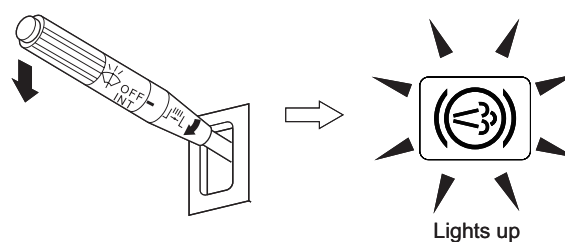

K00380-00E

2. Release the accelerator pedal.
 - The exhaust brake is actuated.

Steering Operation

⚠ WARNING

The vehicle moves in an unusual manner in a special steering. Do not travel on roads in a special steering mode.





Travel on roads in the 2-wheel steering mode.

Use a special steering only for driving in a work site, and travel at a speed of 10 mph (15 km/h) or less.

Use the 2-wheel steering mode when traveling on roads.

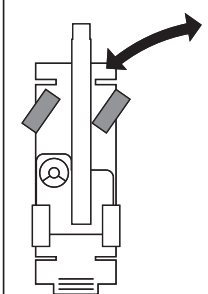
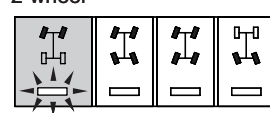
Special steering (4-wheel, crab, rear) is useful in a small area.

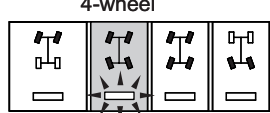
Use an appropriate drive mode depending on the driving applications.

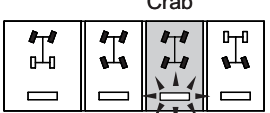
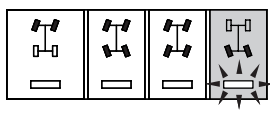
Application	Steering mode	Orientation of steered wheels	Steering mode selector to be selected	Status of lamp and switch	Features
Traveling on roads Driving in work site	2-wheel		2-wheel 	Off-straight-ahead Wheel Indicator  Not lit Special steering warning  Not lit	Only front wheels are steered. This steering method is the same as that of general vehicles.
Driving in work site	Special	4-wheel	4-wheel 	Special steering warning  Lit	Front and rear wheels are steered in opposite directions. The turning radius is decreased. Useful for movement in a small area.
		Crab	Crab 		Front and rear wheels are steered in the same direction. The vehicle can move diagonally. Useful for pulling over.
		Rear	Rear 		Only rear wheels are steered. The rear end of the vehicle swings outward like forklifts. Useful for movement in a small area.

K02797-00E

GR-750XL-2_OM2(U)-17E

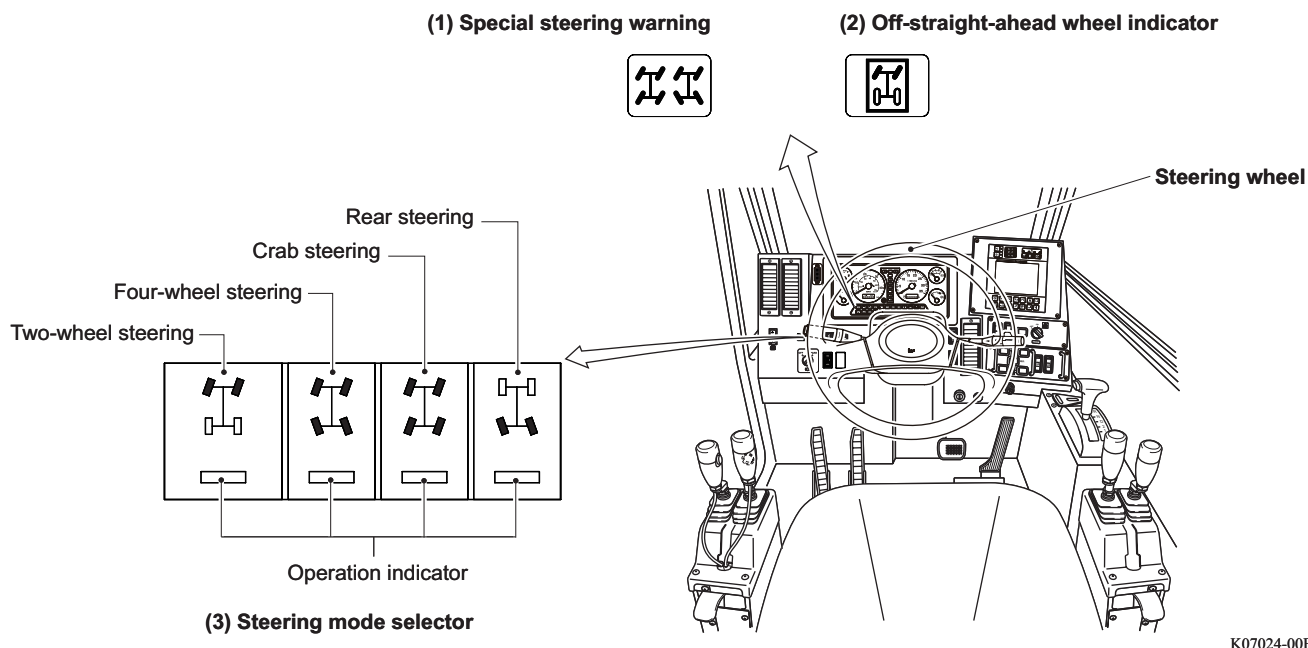

(1) Special Steering Warning

Lights up when a special steering mode is selected, and goes out when 2-wheel steering mode is selected.

(2) Off-Straight-Ahead Wheel Indicator

Goes out when the rear wheels are in the straight-ahead position, and lights up when they are out of the straight-ahead position.

(3) Steering Mode Selector

Selects the two-wheel steering mode or a special steering mode (4-wheel or crab). The operation indicator for the selected steering mode lights up.

Selecting the Steering Mode

⚠ DANGER

Do not travel on roads while the upper swing structure is directed toward over-rear.
Before traveling, return the orientation of the upper swing structure toward over-front.

⚠ WARNING

- The vehicle moves in an unusual manner in a special steering. Do not travel on roads in a special steering mode.
Travel on roads in the 2-wheel steering mode. Use a special steering only for driving in a work site, and travel at a speed of 10 mph (15 km/h) or less.
- While the upper swing structure is directed toward the rear of the carrier, the vehicle is steered in opposite direction with the normal steering wheel operation. Remember that this movement is contrary to the movement when the upper swing structure is directed to over-front. Be careful when you drive the machine.

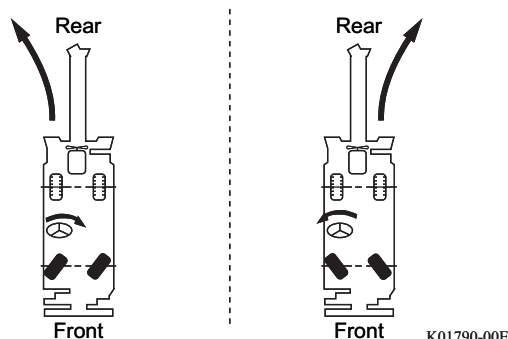

K01790-00E

Changing from the 2-wheel Steering Mode to a Special Steering Mode

The example here explains the steps for changing the 2-wheel steering mode to 4-wheel steering mode.

1. Set the front wheels straight, and stop the vehicle.

⚠ CAUTION

Do not change steering modes while the front wheels are steered left or right. Otherwise, the steering angle of the front wheels does not match that of the rear wheels after the mode change. It makes normal steering impossible.

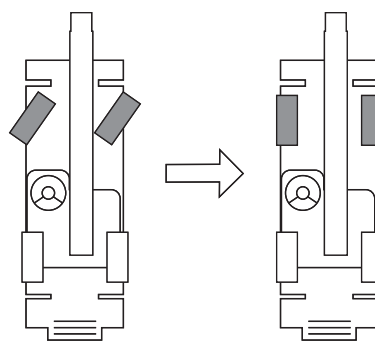

K02799-000

2. Set the shift lever to "N", and apply the parking brake.

3. Select a steering mode with steering mode selector.
 - The "4-wheel" operation indicator lights up.
 - The "2-wheel" operation indicator goes out.

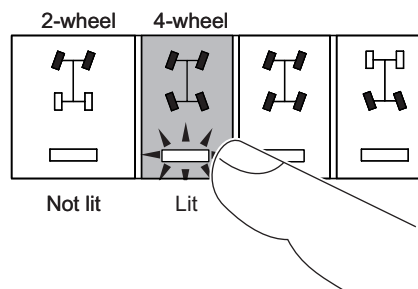

K02800-00E

NOTICE

If the "2-wheel" operation indicator flashes, push the "4-wheel" steering mode again.
 The selected mode is not effective while the "2-wheel" operation indicator flashes.

4. Make sure that the wheels are steered according to the selected mode.

If the rear wheels are not straight when you select a special steering, the off-straight-ahead wheel indicator lights up.

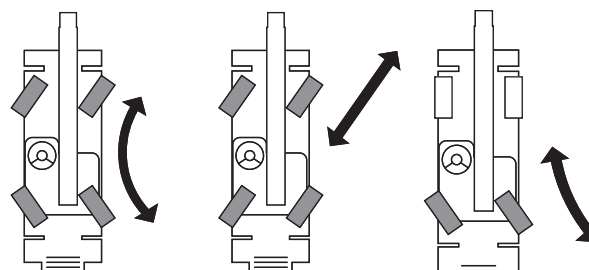
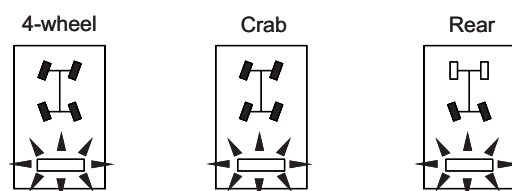

K02801-00E

NOTICE

After you change the steering mode, examine the movement of the wheels before you start traveling.

Changing between the Special Steering Modes

While the off-straight-ahead wheel indicator is not lit, you can change the modes of special steering (4-wheel, crab, and rear).

CAUTION

Do not change the steering mode while the rear wheels are steered left or right.
 Otherwise, the steering angle of the front wheels does not match that of the rear wheels after the mode change, and normal steering is not possible.
 Make sure that the off-straight-ahead wheel indicator is not lit when you change the steering modes.

Goes out

K03904-00E

Changing from a Special Steering to the 2-wheel Steering

⚠ DANGER

Do not travel on roads in special steering mode. The vehicle moves in an unusual manner, and a serious accident can occur.

Before you start to travel in 2-wheel steering, make sure that the lamps and switches are in the condition shown below.

Off-straight-ahead wheel indicator





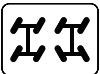

Not lit

Special steering warning



Not lit

Steering mode selector

2-wheel	4-wheel	Crab	Rear
			
Lit	Not lit		



OK!

K02802-00E

The example here explains the steps for changing the 4-wheel steering mode to 2-wheel steering mode.

1. Set the rear wheels straight, and stop the vehicle.
 - The off-straight-ahead wheel indicator goes out.

⚠ CAUTION

Do not change the steering mode with the rear wheels are steered left or right. Otherwise, the steering angle of the front wheels does not match that of the rear wheels after the mode change. It makes normal steering impossible. Make sure that the off-straight-ahead wheel indicator is not lit.

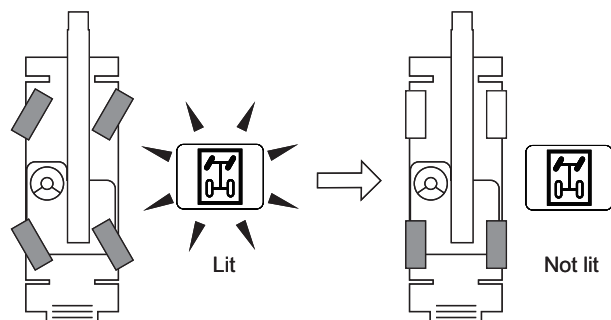

K02803-00E

2. Set the shift lever to "N", and apply the parking brake.

3. Push the "2-wheel" steering mode selector.
- The "2-wheel" operation indicator lights up.
 - The "4-wheel" operation indicator goes out.

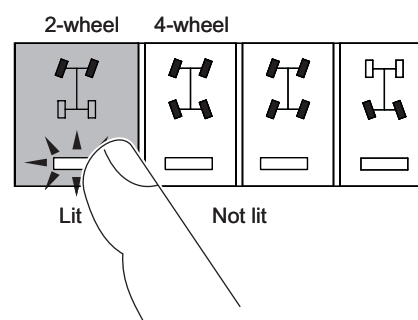

⚠ WARNING

Do not travel while the "4-wheel" operation indicator flashes. The mode is not changed back to 2-wheel steering. It can cause a serious accident. Before traveling make sure that the "4-wheel" operation indicator is not lit, and the 2-wheel operation indicator is lit.

K02804-00E

NOTICE

If the special steering warning or off-straight-ahead wheel indicator lamp does not go out, inspection is necessary. Contact your nearest TADANO distributor or dealer.

4. Make sure that the wheels are steered according to the selected mode.

⚠ WARNING

If the off-straight-ahead wheel indicator lamp lights up during traveling, stop traveling and check whether the rear wheels are in the straight-ahead position. If you continue traveling while the rear wheels are out of the straight-ahead position, a serious accident can occur.

⚠ CAUTION

After you change the steering mode to the 2-wheel steering mode, make sure that only the front wheels are steered before you start to travel.

Drive Mode Selection

There are the 3 types of drive modes as shown below.

Use an appropriate drive mode depending on the driving applications.

Application	Drive mode	Position of drive mode selector	Driving wheel	State of indicator	Feature
Normal traveling	2WD			4WD indicator Not lit Low travel speed indicator Not lit	Use this mode when traveling on a general road.
4WD traveling	H/4D			4WD indicator Lit Low travel speed indicator Not lit	Use this mode when traveling on a slippery road such as a rough road and snow-covered road.
4WD low speed traveling	L/4D			4WD indicator Lit Low travel speed indicator Lit	Use this mode when traveling on a steep slope or during on-rubber operation.

K01576-00E

Low travel speed indicator

Lights up when L/4D is selected.



4WD indicator

Lights up when H/4D or L/4D is selected.

Drive mode selector

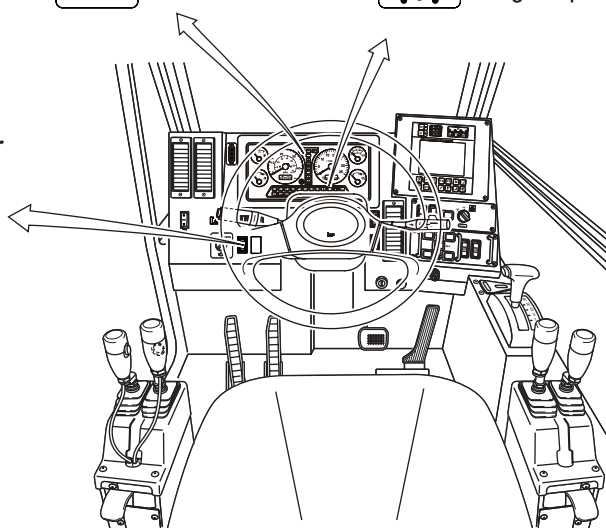
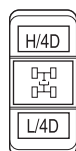

K07025-00E

Drive Mode Selection

NOTICE

- If you operate the drive mode selector while traveling, the driving system can be damaged. Stop the vehicle first, then operate the selector.
- 4WD driving applies a larger load to the driving system compared to 2WD driving. Use 4WD only when traveling on a slippery road such as a rough road and snow-covered road.

1. Stop the vehicle on a flat area.
2. Change the drive mode with the drive mode selector.

(The illustration shows a case when the L/4D [4WD low speed traveling] is selected.)

- The "4WD indicator" lights up.
- The "Low travel speed indicator" lights up.

 The mode is not changed to the selected mode while the "4WD indicator" flashes. If the drive mode does not change, move the vehicle slightly and stop, and then operate the selector again.

 If you start the vehicle while the 4WD indicator flashes, the alarm sounds.

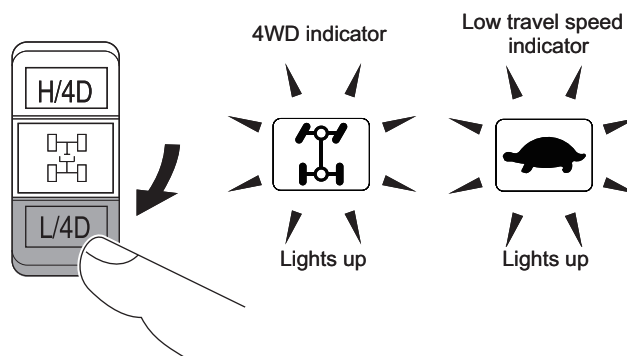

K00393-00E

3. Make sure that the applicable indicator is lit.

Lighting Switch and Other Switches

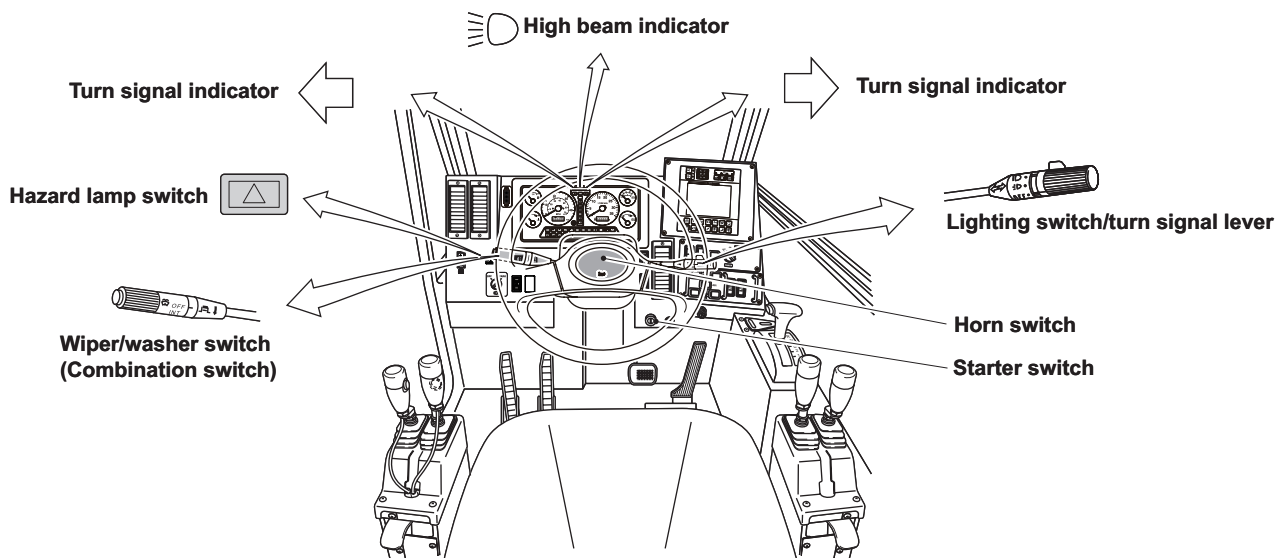

K07026-00E

Lighting Switch

This switch works while the starter switch is "ON".

When the light switch knob is turned to the position of "☺" or "☹", lamps with the mark ○ in the list below light up.

Position of knob	☺	☹
Head lamp	-----	○
Clearance lamp, Tail light	○	○
License plate lamp		
Switch illumination		

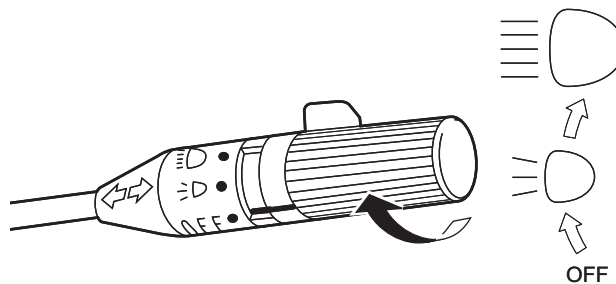

G21002-000

Turning the Head Lamps to High Beam

Push the lever to the front when the light switch is at the position of "  ".

- The high beam indicator on the instrument panel lights up.

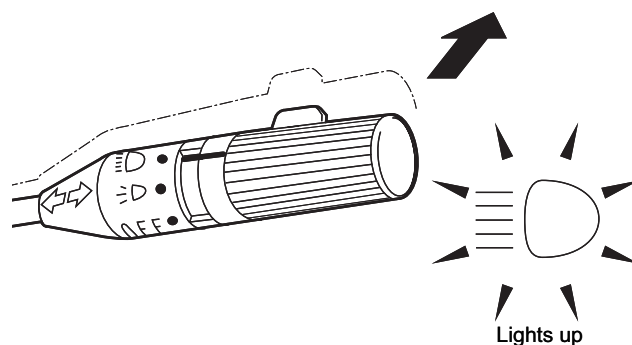

G21003-00E

Flashing the Head lamps

Pull the lever toward you.

- The high beam indicator on the instrument panel lights up.

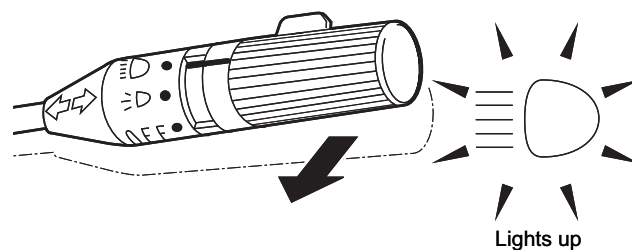

G21004-00E

Turn Signal Lever

This switch operates regardless of the starter switch position.

When the turn signal lever is operated upward or downward, the turn signal lamps flash.

- The related turn signal indicator on the instrument panel flashes.

- ☞ The lever moves back to the initial position automatically when you turn back the steering wheel. If the lever does not move back, move it by hand.
- ☞ When you change lanes, you can operate the turn signal lamps by pushing up/down the lever lightly. The turn signal lamps flash while you push the lever.
- ☞ When a bulb of the turn signal lamp is burned out or a bulb with incorrect capacity (wattage) is set, flashing frequency is changed.

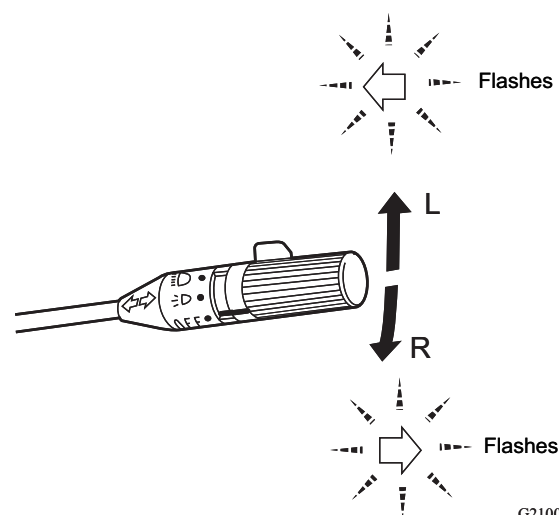

G21005-00E

Hazard Lamp Switch

This switch operates regardless of the starter switch position.

When you must park the machine on a road due to a failure, etc., use this switch to alert the following vehicles.

1. When the hazard lamp switch is pushed, all the turn signal lamps flash.

- The turn signal indicators on the instrument panel flash.

 Do not use the hazard lamps for a long time when the engine is stopped. The battery can be exhausted.

2. When you push the switch again, the lamps go out.

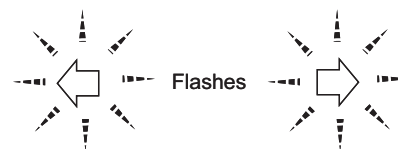

Hazard lamp switch

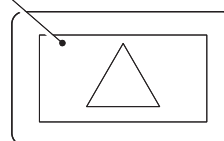

G21006-00E

Horn Switch

This switch operates while the starter switch is "ON".

When you push the horn switch, the horn sounds.

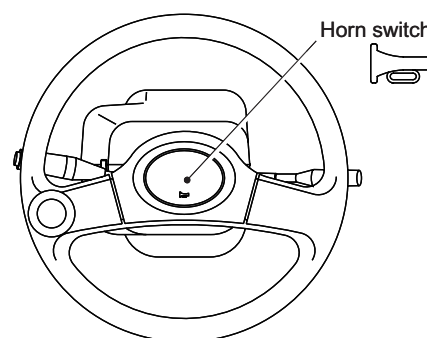

K00399-00E

Wiper

This switch works while the starter switch is "ON".
When you turn the wiper/washer switch knob, the wiper operates as shown in the figure.

- During intermittent operation, the wiper operates at approximately every other 5 seconds.

- ☞ If the wiper is operated while the glass is dry, the glass is scratched. Spray washer liquid before you operate the wiper.
- ☞ When the glass is frozen or the wipers are not used for a long time, make sure that the wiper blades do not stick to the glass. If you operate a wiper while its blade is stuck to the glass, the blade will suffer damage.

HI ↑ High speed operation
LO ↑ Low speed operation
INT ↑ Intermittent operation
OFF Stop

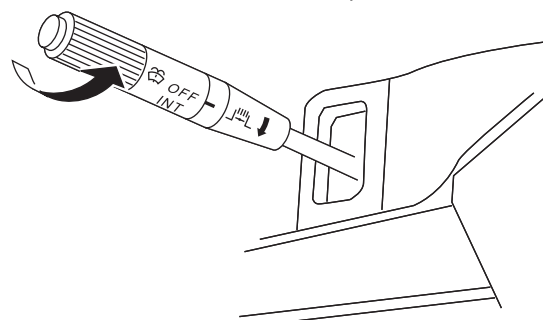

G21008-00E

Spraying the Washer Liquid

Push the knob at the top end of the wiper/washer switch.

- Washer liquid is sprayed on the windshield.

NOTICE
<p>Do not use washer liquid in cold season until the glass surface becomes warm. Otherwise, washer liquid freezes on the windshield glass, and impairs visibility.</p>

- ☞ If the washer liquid does not come out, do not keep pressing the washer switch. The washer fluid pump will be damaged. Examine washer liquid level and clogging of the washer nozzle.

Spray washer liquid

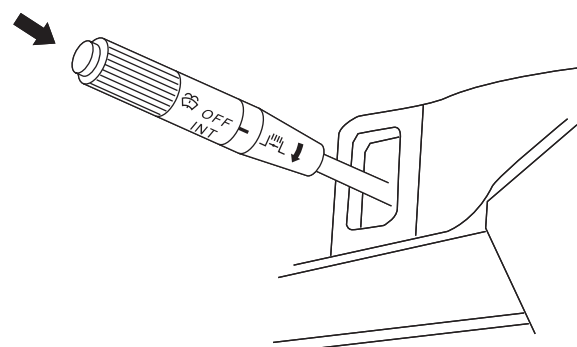

G21009-00E

Refilling the Washer Liquid

1. Remove the washer liquid tank cover on the front side of the cab.
2. Add washer liquid into the window washer tank.

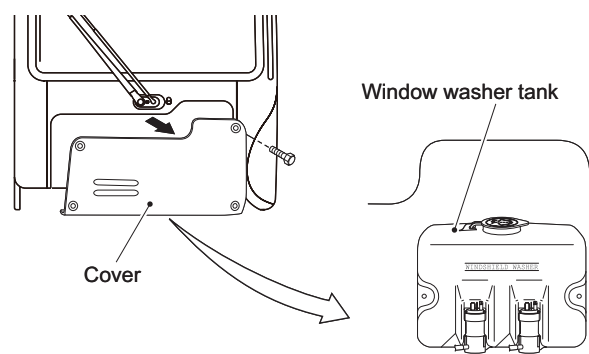

K01791-01E

Accessories in Cab

CAUTION

When you operate an accessory in the cab during traveling, be careful that safe driving is not hindered.

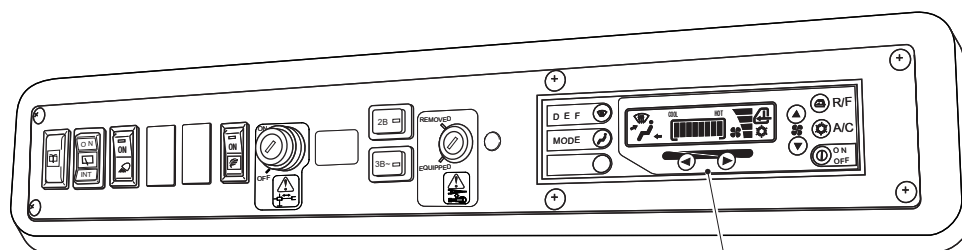
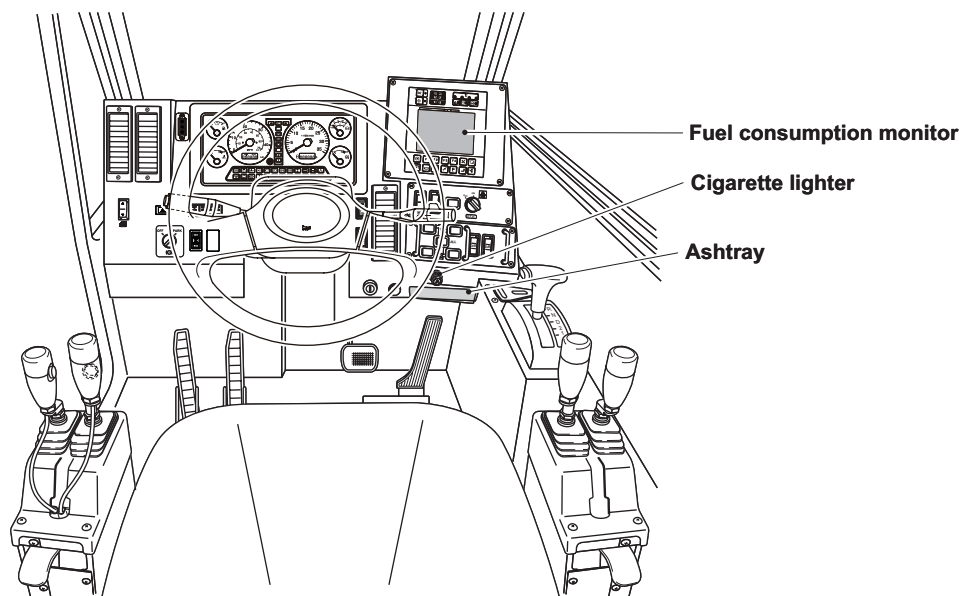

Air conditioner control panel

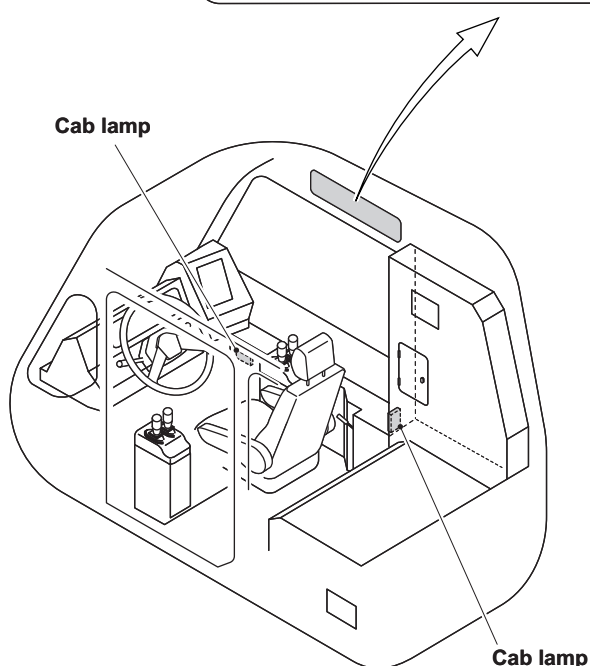

K07027-00E

GR-750XL-2_OM2(U)-17E

Fuel Consumption Monitor

CAUTION

Do not operate the fuel consumption monitor while traveling. It may cause an accident.
When you operate the fuel consumption monitor in the cab during traveling, be careful that safe driving is not hindered.

The fuel consumption rate during traveling is indicated.

Checking the items on the fuel consumption monitor enables you to operate a crane in an environmentally friendly way.

The following items are shown.

- Current fuel consumption.....
The current fuel consumption during traveling is shown as a bargraph.
- Average Fuel Consumption.....
The average fuel consumption during traveling is shown in MPG (mile/gallon).
It is reset when the display changes to "At standby", or PTO is set to "ON".
- Fuel consumption during standby
- Standby period.....
The standby period is displayed in minute.

 The standby period is the period when a crane is stopped and the shift lever is in neutral position.

 Fuel consumption during standby and standby period are displayed when a specific time has passed since a crane became standby.

 The fuel consumption monitor is always on. However, you cannot read the monitor during nighttime, because the back light of the monitor is turned off in order not to hinder a safe driving.

 The displayed data may be different from the actual value depending on traveling conditions. Check the fuel gauge to see the remaining fuel amount.

At traveling

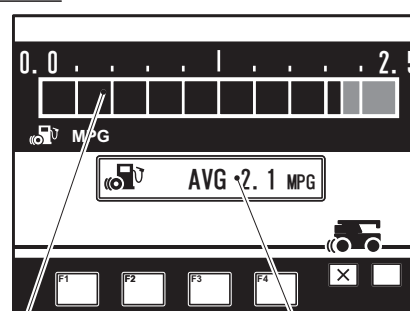

Current fuel consumption

Average fuel consumption

At standby

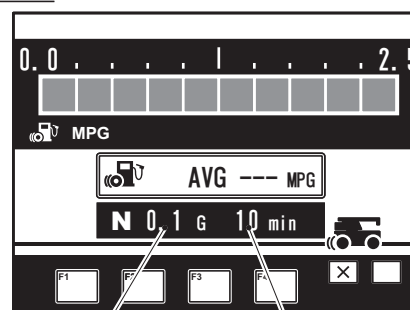

Fuel consumption during standby

Standby period

K06220-00E

Fuel Consumption History Display

1. Stop a vehicle and set the shift lever to neutral position.
2. Push the preset menu key.
 - The pop-up window for preset menu selection is shown on the display.

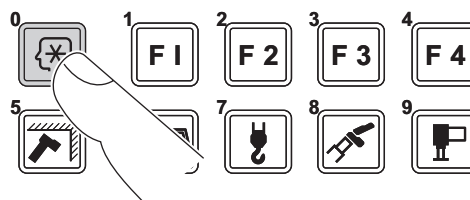

K00702-000

3. Press the F3 (Backward) or F4 (Forward) key to select one of the fuel consumption history icon.

 If the Telematics data transmission icon is selected, the screen for data transmission to the HELLO-NET server appears. For procedure of Telematics data transmission, refer to "Preset menu" (page 171)".

Fuel consumption history icon Telematics data transmission icon

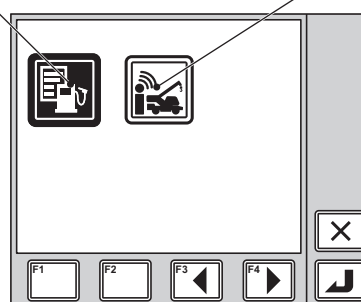

K03075-01E

4. Press the set key.
 - The screen for fuel consumption history appears.

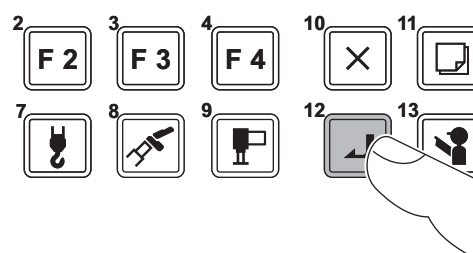

K00678-000

5. The display changes when the display change key is pushed.

- History of the fuel consumption and the average fuel consumption is shown in either a bargraph or number.
- The items shown on the numerical display screen are as follows:

G(N) Fuel consumption when standby

G(D) Fuel consumption when traveling

MPG Average fuel consumption during standby and traveling (mile/gallon).

 The measurement restarts when F1 (reset) key is pushed.

The previous records are moved down every time the F1 (reset) key is pushed. 6 previous records (Max.) including the current rate are displayed.

You can reset the histories both for traveling and crane operation at the same time by pushing F1 (reset) key and hold it for a while.

 Press cancel key to exit the history display. The pop-up window closes and the screen changes back to the original crane traveling mode.

Bargraph display

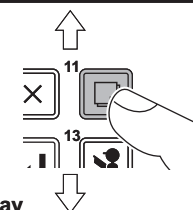
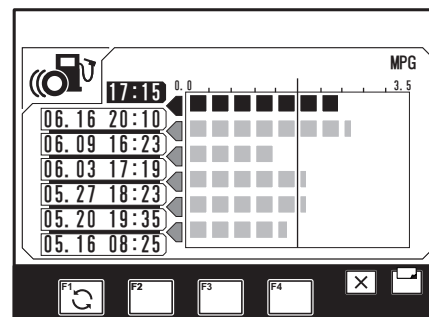

Numeric display

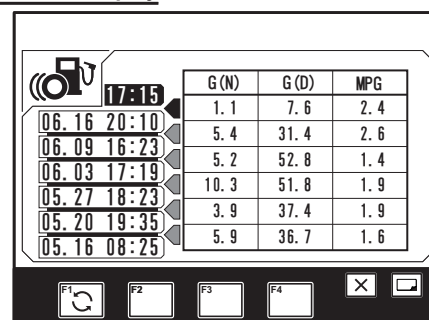

K03076-02E

Air Conditioner

NOTICE

Obey the precautions below to prevent a failure of the air conditioner.

- Use the air conditioner after the engine is started. Before you stop the engine, set the power switch of the air conditioner to "OFF".
- Do not put objects in front of the air vent louver that disturb the air flow.

Dehumidifying/Cooling Operation

 Cooling operation lowers temperature and humidity. The temperature is optimal for your health when it is lower than the ambient temperature by 9°F to 14°F (5°C to 8 °C). Do not turn the temperature level down excessively, and do not expose yourself to cool air for a long time. Set the temperature to a suitable level.

 Dehumidifying operation makes inside of the cab dry.

1. Start the engine.
2. Push the power switch.
 - The power of the air conditioner is turned on and the indication of LCD appears.
3. Set the air conditioner switch to "ON".
 - The dehumidifying/cooling function activates, and the snow-shaped sign appears.

 When the ambient temperature drops near to 32°F (0 °C), the dehumidifying/cooling function does not operate.

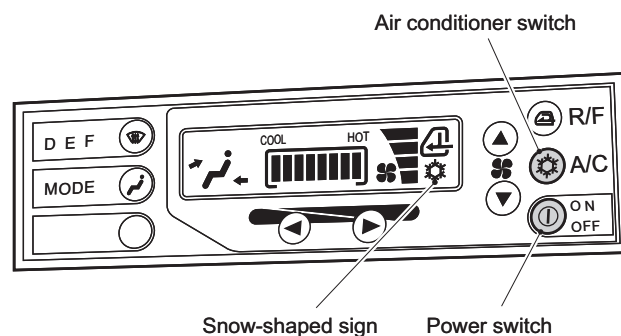

K01965-00E

4. Adjust the air flow volume, temperature, etc.

- Air flow volume:

Press the air flow switches to adjust.

Four levels are available.

- Inside/outside air selector:

Each time you push the inside/outside air selector switch, the mode changes between the air circulation inside cab and the outside-cab air supply.

☞ Use the air circulation inside cab only temporarily to lower the temperature quickly, or to prevent dust intrusion when the machine travels through a tunnel or other situations.

☞ If the air circulation inside cab is selected while the air conditioner is deactivated, the window glass can be fogged easily.

- Temperature:

Push the temperature control switches to adjust.

Eight levels are available.

- Air direction:

Push the air outlet changeover switch.

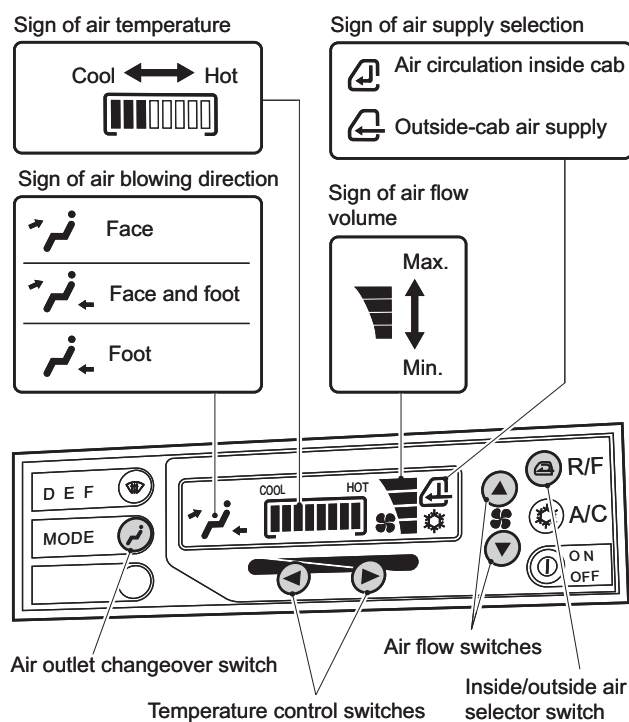

K01966-00E

Heating Operation

1. Start the engine.
2. Push the power switch.
 - The power of the air conditioner is turned on and the indication on the LCD panel appears.
3. Set the air conditioner switch to "OFF".
4. Adjust the air flow volume, temperature, etc., similarly to the dehumidifying/cooling operation.

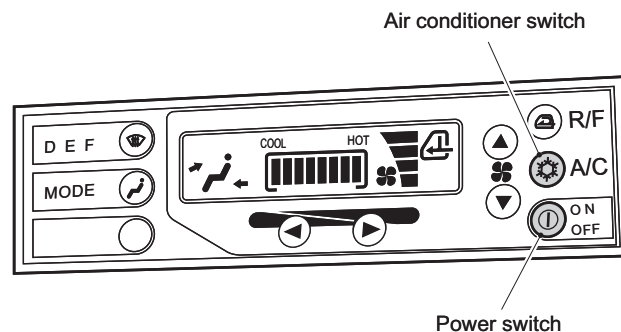

K01967-00E

NOTICE

In extremely cold regions, do not use air circulation inside cab.
Once the window glass gets fogged, it can stay for long even after the outside-cab air supply is selected.

- ☞ Use the air circulation inside cab only temporarily to raise the temperature quickly or prevent dust intrusion when the machine travels through a tunnel or other situations.
- ☞ If the air circulation inside cab is selected while the air conditioner is deactivated, the window glass can be fogged easily.

Operating Defroster

1. Start the engine.
2. Push the power switch.
 - The power of the air conditioner is turned on and the indication on the LCD panel appears.
3. Set the air conditioner switch to "ON".
 - The dehumidifying/cooling function activates, and the snow-shaped sign appears.

 When the ambient temperature drops near to 30°F (0°C), the dehumidifying/cooling function does not operate.

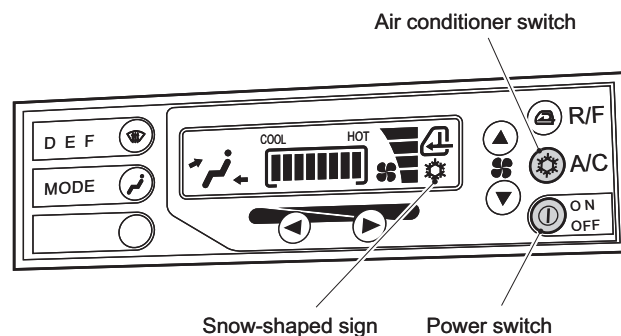

K01965-00E

4. Push the defroster switch.
 - The air vent changes to the defroster mode, and the sign of defrosting is shown.

 When you push the air outlet changeover switch, the previous air vent mode is activated.

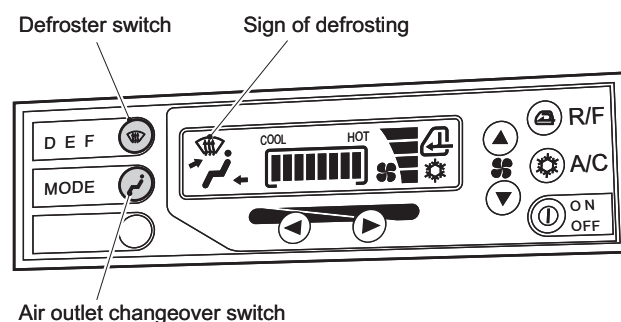

K01968-01E

5. With the same procedure as the dehumidifying/cooling operation, adjust air flow volume and temperature.
6. Push the inside/outside air selector switch to select the outside-cab air supply.

Errors Shown on the LCD (Liquid Crystal Display)

If any of the indications below is shown on the LCD, an open/short circuit in the wiring of the sensor or motor actuator is the likely cause. Contact your nearest TADANO distributor or dealer for repair.

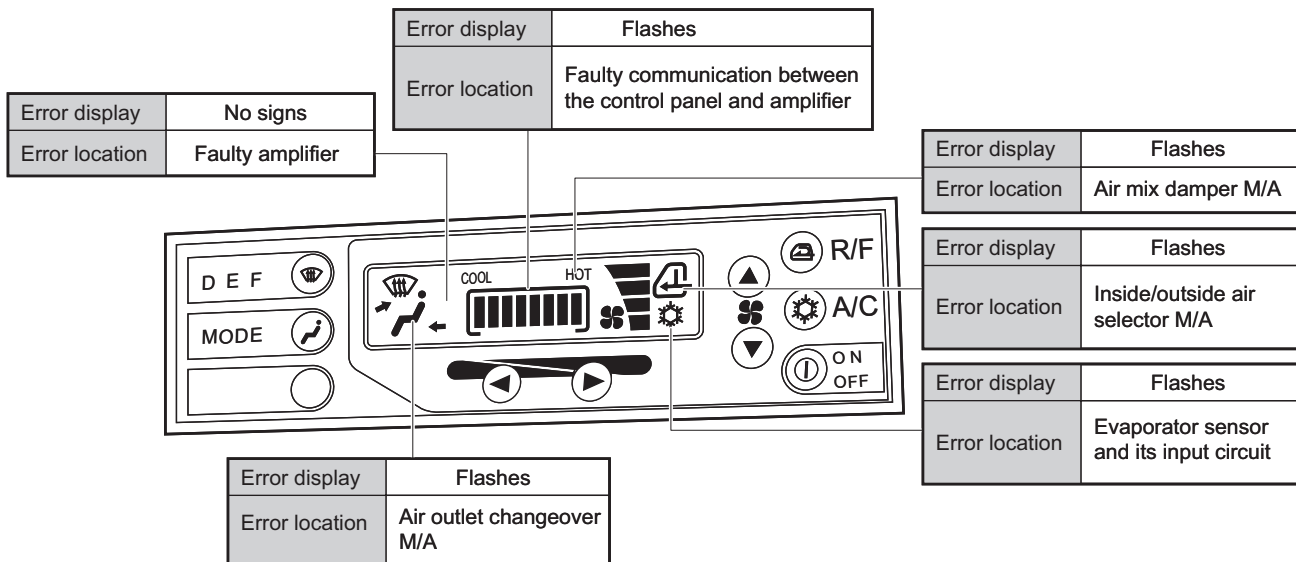

K01969-00E

Cab Lamp

Left Side in Cab , Door Side

- "OFF" Does not light up regardless of opening/closing of the door.
- Neutral Lights up when the door is opened, and goes out when closed.
- "ON" Stays lit regardless of opening/closing of the door.

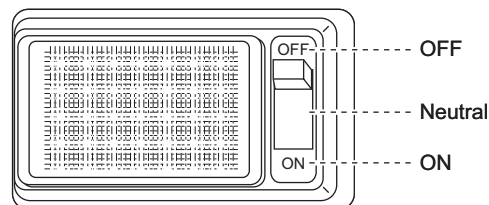

K01976-00E

Right Side in Cab

- "OFF" Does not light up.
- Neutral, "ON" Stays lit.

Cigarette Lighter

When you push in the cigarette lighter, it moves back to its initial position after several seconds.

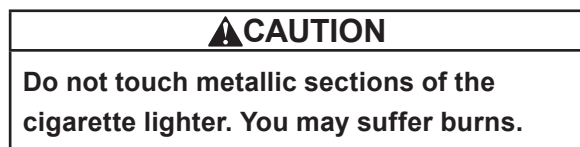

- ☞ Obey the precautions below to prevent faults in the electrical system.
- Do not push and hold the cigarette lighter.
 - If the cigarette lighter does not move back to its initial position in 15 to 20 seconds, pull it out by hand.
 - When you use the cigarette lighter as a power outlet, its rated capacity is 24-V DC-15A. Do not take out power that exceeds the capacity.

K01977-000

Outside Cab Accessory

Radiator Cover

NOTICE

**Install the radiator cover according to the ambient temperature and operating conditions.
An inadequate use of the radiator cover can cause machine damage or an accident.**

Use the radiator cover according to the ambient temperature in a cold season, etc.

Ambient temperature is 13°F (-25°C) or below.	Ambient temperature is below 14°F (-10°C).	Ambient temperature is 14°F (-10°C) or above.	When traveling.
Install the radiator cover and run the engine at 1,400 min ⁻¹ {rpm} or over.	Install the radiator cover and run the engine at 1,000 min ⁻¹ {rpm} or over.	Remove the radiator cover.	

How to Install Radiator Cover

Put the hooks on the crane body through the fixing holes in the radiator cover.

Fix the radiator cover to the crane body with ropes etc. using the fixing holes in the lower end of the radiator cover so that the cover fits the crane body closely.

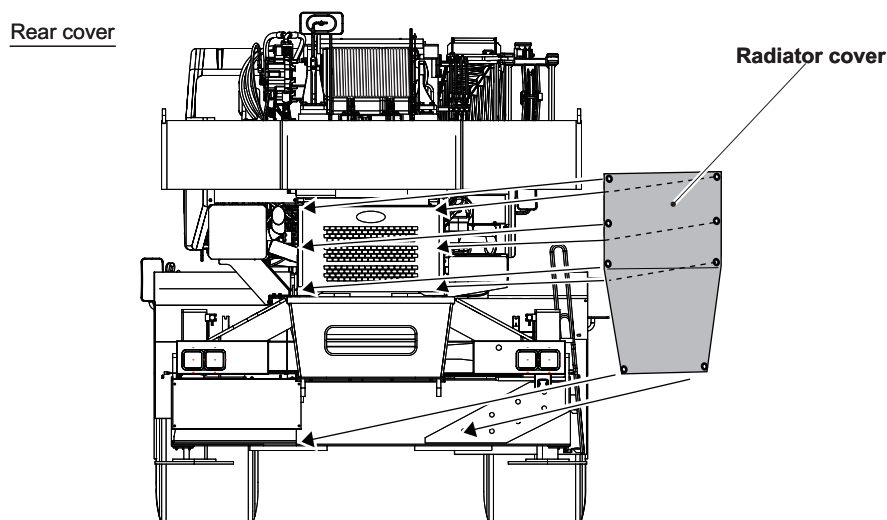

K07028-00E

Handling Tires

Tire Air Pressure

⚠ WARNING

Check that the air pressure of the tires is at the specified level (refer to "Service Data" [page 455]).

If the air pressure of the tires is out of the specified level, traveling the machine can damage the tires or cause an accident.

Adjust tire air pressure before travelling while the tires are cold.

Check that tire air pressure is at the specified level.

 For the method to check tire air pressure, refer to "Inspection and Maintenance" (page 307).

Long-time Parking

If you need to park the machine for a long time, extend the outriggers and lift the tires off the ground to prevent deformation of the tires.

Restriction of Continuous Traveling

Stop the machine periodically during traveling to cool down the tires. This practice extends the service life of the tires and also helps the tires to deliver their full performance.

The time needed for cooling tires differs depending on the ambient temperature and tire size.

See the nameplate located in the cab.

Maximum average speed				19 mph (30 km/h)		22 mph (36 km/h)	
Tire	Air pressure	Traveling cycle	Ambient temperature	Traveling time	Cooling time (Stopping time)	Traveling time	Cooling time (Stopping time)
29.5-25-22PR (BRIDGESTONE VL2A E-3A) (TOYO TIRE G62 E-3)	50 psi (350 kPa)		100 °F (38 °C)	180 min.	210 min.	60 min.	210 min.
			122 °F (50 °C)	60 min.	270 min.	40 min.	270 min.
29.5-25-28PR E-3	47 psi (330 kPa)		100 °F (38 °C)	120 min.	120 min.	60 min.	150 min.
		122 °F (50 °C)					

Operation in Cold Season

Winterization

When you change the engine oil, fuel, or coolant according to the air temperature, refer to "INSPECTION AND MAINTENANCE" (page 307).

Engine Oil

Use an oil with viscosity suitable to the ambient temperature.

Fuel

Diesel fuel of ASTM D-975 number 2-D freezes at the ambient temperature of 32 °F (0 °C) or below, and this prevents engine startup. Use winter blend fuels (combinations of number 2-D and number 1-D of ASTM D-975).

 Use ultra-low sulfur diesel (ULSD) only.

Refer to the separate engine manual for details.

Coolant

Mix the long life coolant (LLC) with water in a 50:50 ratio.

Washer Liquid

Use the washer liquid suitable for winter season.

Battery

When the ambient temperature drops, performance of the battery degrades and the engine may not be started. Examine the level and specific gravity of the battery electrolyte, and add the battery fluid or charge the battery as necessary.

Tire Chain

WARNING

If you do not obey the precautions below, the vehicle structures such as the brake piping can be damaged, and an accident can occur.

- **When you attach tire chains, examine the inside of the fenders to make sure that the chains do not interfere with the adjacent components such as the brake hoses in the fender.**
- **Do not travel in the special steering mode while tire chains are used.**
- **If there is an unusual sound during traveling, immediately stop the vehicle and inspect it. If the tire chains are broken or come off, they can hit and hurt the persons nearby.**

Obey the precautions below when you attach tire chains.

(1) Attach tire chains to the rear wheels only.

(2) Set the steering mode to "2-wheel", and set drive mode to "L/4D" or "H/4D".

OPERATION

Terminology

Boom Length

The distance between the boom foot pivot (foot pin) and the boom top sheave center (point pin).

Boom Angle

The angle between the boom center line and the horizontal line.

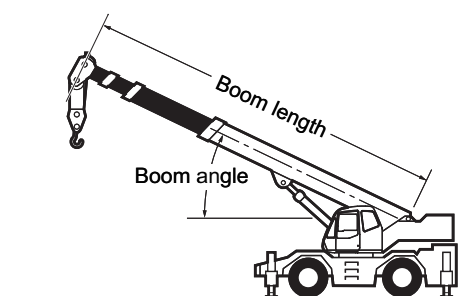

K01727-00E

Jib Length

The distance between the jib foot pivot (foot pin) and the jib top sheave center (point pin).

Jib Offset Angle

The angle between the boom center line and the jib center line when the jib is installed.

Jib Tilt

To change jib offset angle.

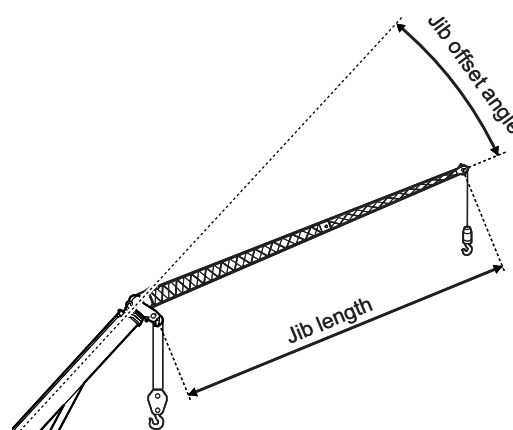

K01802-00E

Working Radius

The horizontal distance between the center of rotation and center of the hook block.

Lifting Height

The distance between the ground and lower end of the hook block when the hook block is at its upper limit position in each load radius.

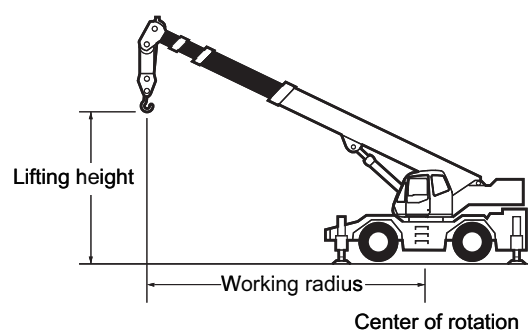

K01729-00E

Extension Width of Outriggers

H-type outrigger specification

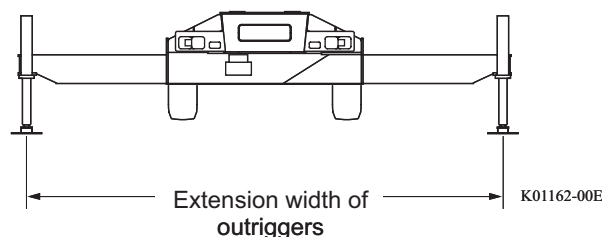

Unequal Extension of Outriggers

The condition that the individual extension width of outrigger is different from each other.

Maximum Extension Capacity, Middle Extension Capacity, Minimum Extension Capacity

The lifting capacities when the outriggers are extended to respective width.

Rated Lifting Capacity

The maximum load that can be lifted with the specified boom length and load radius.

The rated lifting capacity is the total mass of a lifted load and lifting devices such as rigging wires and the hook block.

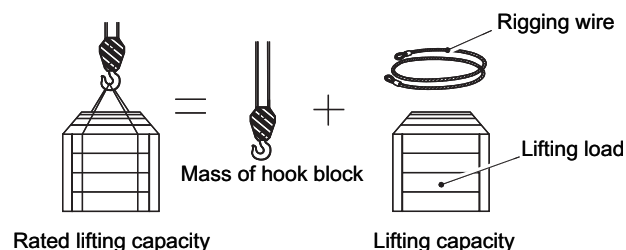

Lifting Capacity

The load that can be actually lifted. You can calculate the value by subtraction of the mass of lifting devices such as the hook block from the rated lifting capacity.

G31005-00E

No Load

The condition that no load is lifted.

On-rubber Stationary Operation

To carry out crane operation without using outriggers.

On-rubber Creep Operation

To pick and carry a load (travel at low speed with a load lifted and without extending outrigger jacks).

Clearing the Ground

To lift a load off from the ground by hoist-up operation.

Before Crane Operation

Pre-operational Inspection

⚠ WARNING

If you do not do pre-operational inspection, you cannot find a failure early, and it can cause an accident. Inspect the machine before operation to make sure that there is no abnormality.

When you inspect the crane, refer to "Inspection before Traveling" (page 332) and "Pre-operational Inspection" (page 351).

Preparing for Crane Operation

Set the machine from the traveling configuration to the crane operation configuration.

1. Set up the outriggers, and register the outrigger status to the "Load Moment Indicator (AML)".
For setup and status registration of the outriggers, refer to "Outriggers" (page 192) and "Load Moment Indicator (AML)" (page 137).

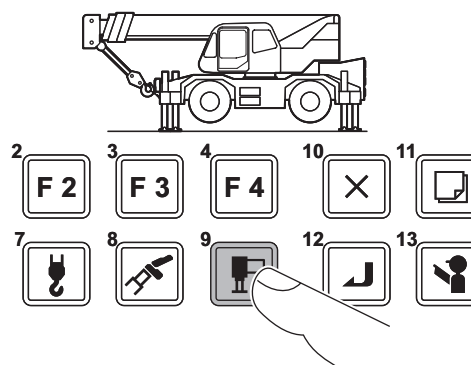

K01580-000

2. Take out the main hook block from the stowing position. For taking out of the hook block, refer to "Taking Out and Stowing the Hook Block" (page 225).

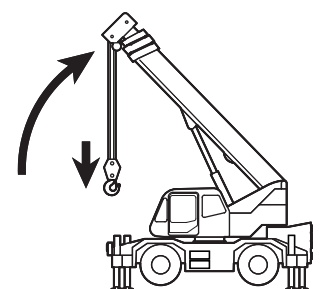

K01581-000

3. Register the lift status to the load moment indicator. For registration of the lift status, refer to "Load Moment Indicator (AML)" (page 137).

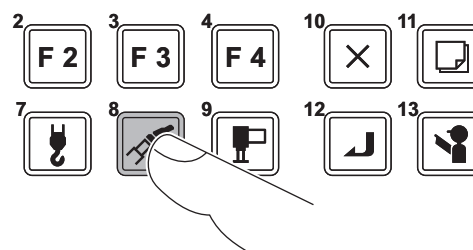

K00529-000

4. Register the number of part line to the load moment indicator. For registration of the number of part line, refer to "Load Moment Indicator (AML)". (page 137).

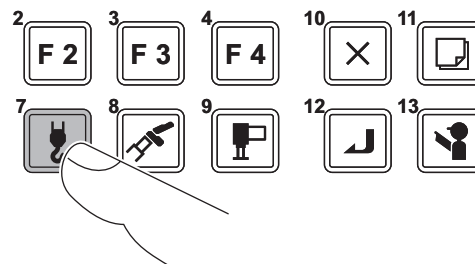

K00531-000

5. Check the function of the load moment indicator. To check the function of the load moment indicator, refer to "Load Moment Indicator (AML)" (page 137).

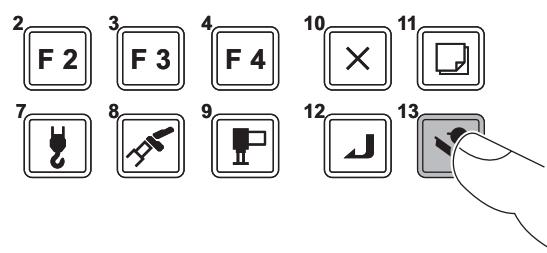

K00530-000

⚠ WARNING

If you operate the crane while the load moment indicator (AML) has an abnormality, the machine does not automatically stop even when an overload occurs. The machine can overturn or suffer damage, and it can cause a fatal accident. Examine the function of the load moment indicator (AML) and make sure that there is no abnormality.

6. Start the crane operation.

How to Read Performance Data Plates

Working Range Chart

Working range chart shows the relations between the boom length, boom angle, load radius, and lifting height.

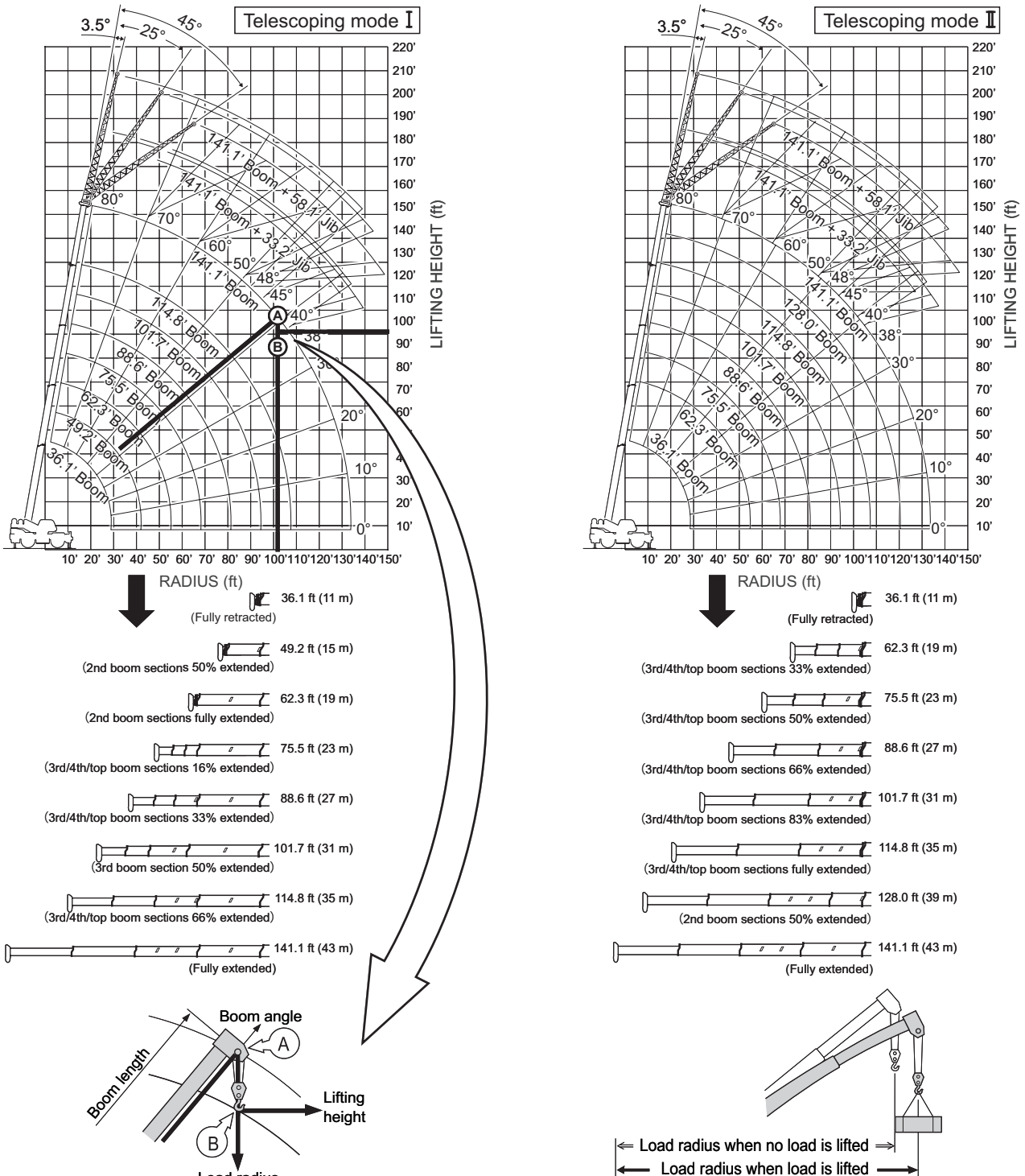

Point A has the same load radius as point B, however, point A represents a boom angle and point B represents a lifting height.

The working range chart does not include deflection of boom. Note that, when the load is lifted, radius is extended due to deflection of the boom depending on loads.

K02692-01E

The above figure shows an example of working range charts. For the actual values, see the working range chart provided in your cab.

GR-750XL-2_OM2(U)-17E

Metric ton Specifications (Option)

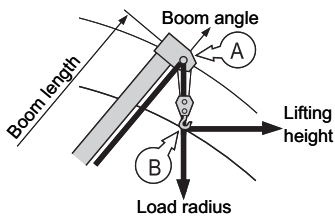
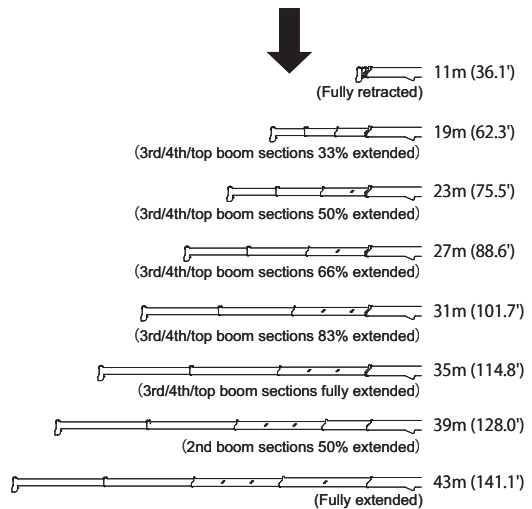
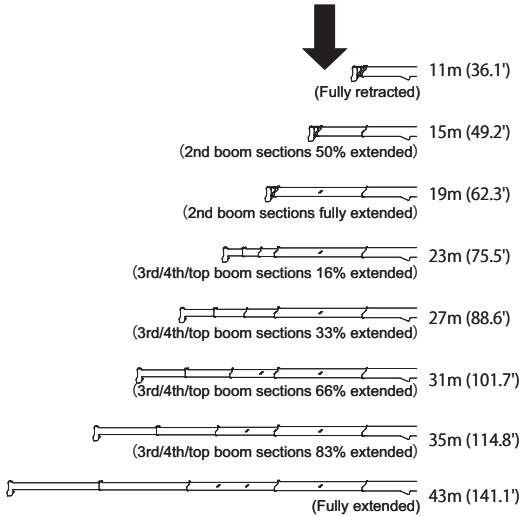
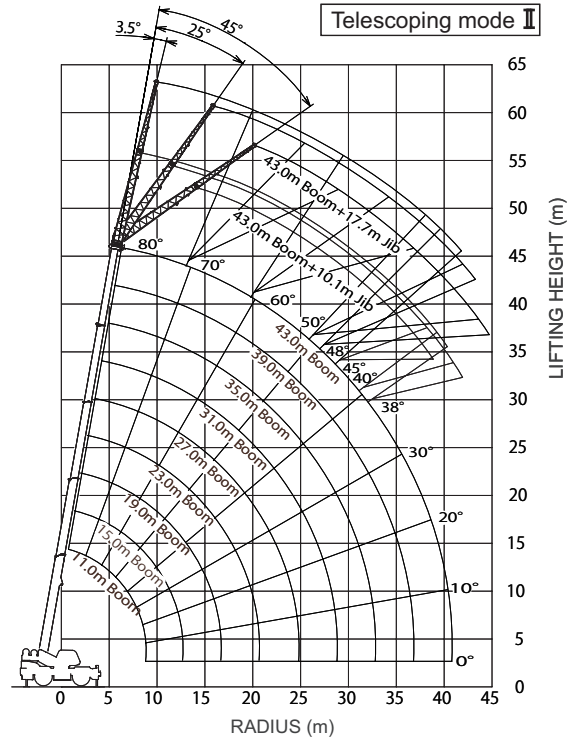
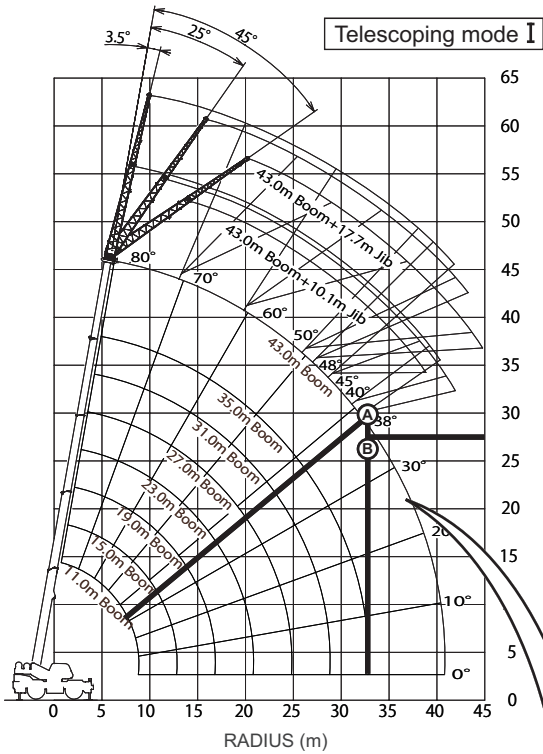

Point A has the same load radius as point B, however, point A represents a boom angle and point B represents a lifting height.

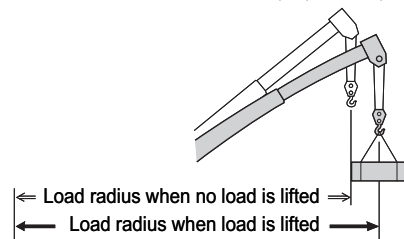

The working range chart does not include deflection of boom. Note that, when the load is lifted, radius is extended due to deflection of the boom depending on loads.

K06065-00E

The above figure shows an example of working range charts. For the actual values, see the working range chart provided in your cab.

Rated Lifting Capacity Table

⚠ WARNING

Do not operate the crane with a load exceeding the rated lifting capacity. The machine can overturn or be damaged, and this can cause a fatal injury.

The rated lifting capacity table specify the capacity for each condition according to the lift status and extension width of outriggers. Find the correct rated lifting capacity before operation.

- Boom lift
- Single top lift
- 33.2 ft. (10.1 m) Jib lift
- 58.1 ft. (17.7 m) Jib lift
- On-rubber boom lift
- On-rubber single top lift

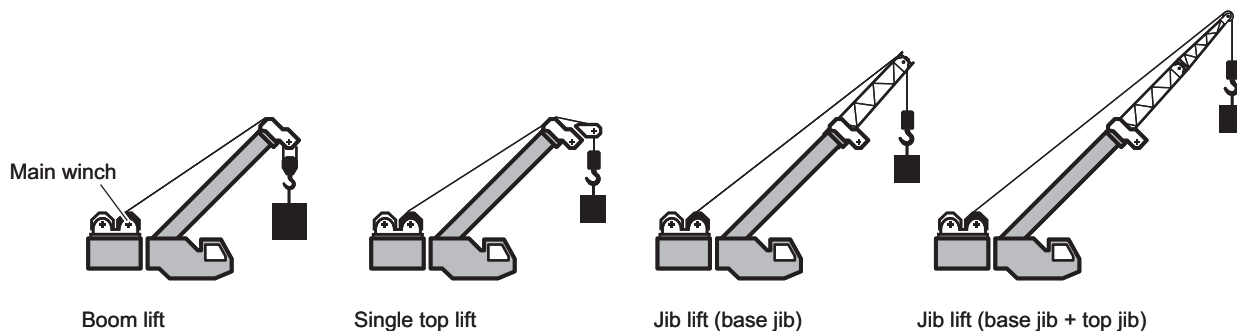

K03089-00E

- ☞ To use the auxiliary winch, refer to "Selection of winch to be used" (page 177) and change the winch you use accordingly.
- ☞ If boom lift is performed with the single top or jib mounted on the boom head, refer to "Reduction of Rated Lifting Capacity" (page 135) and operate accordingly.

NOTES FOR LIFTING CAPACITIES

GENERAL

1. RATED LIFTING CAPACITIES apply only to the machine as originally manufactured and normally equipped by TADANO LTD.
Modifications to the machine or use of optional equipment other than that specified can result in a reduction of capacity.
2. Hydraulic cranes can be hazardous if improperly operated or maintained. Operation and maintenance of this machine must be in compliance with information, in the Operation and Maintenance Manual supplied with the crane. If this manual is missing, order a replacement through the distributor.
3. The operator and other personnel associated with this machine shall fully acquaint themselves with the latest American National Standards Institute (ANSI) safety standards for cranes.

SET UP

1. Rated lifting capacities on the chart are the maximum allowable crane capacities and are based on the machine standing level on firm supporting surface under ideal job conditions. Depending on the nature of the supporting surface, it may be necessary to have structural supports under the outrigger floats or tires to spread the loads to a larger bearing surface.
2. For outrigger operation, outriggers shall be properly extended with tires free of supporting surface before operating crane.

OPERATION

1. Rated lifting capacities have been tested to and meet minimum requirements of SAE J1063-Cantilevered Boom Crane Structures Method of Test.
2. Rated lifting capacities do not exceed 85% of the tipping load on outriggers fully extended as determined by SAE J765-Crane Stability Test Code. Rated lifting capacities for partially extended outriggers are determined from the formula, Rated Lifting Capacities = (Tipping Load-0.1 x Tip Reaction)/1.25.
3. Rated lifting capacities above thick lines in the chart are based on crane strength and those below, on its stability. They are based on actual load radius increased by boom deflection.
4. The weight of handling device such as hook blocks, slings, etc., must be considered as part of the load and must be deducted from the lifting capacities.
5. Rated lifting capacities are based on freely suspended loads and make no allowance for such factors as the effect of wind, sudden stopping of loads, supporting surface conditions, inflation of tires, operating speeds, side loads, etc. Side pull on boom or jib is extremely dangerous. Such action can damage the boom, jib or swing mechanism, and lead to overturning of the crane.
6. Rated lifting capacities do not account for wind on lifted load or boom. We recommend against working under the condition that the load is out of control due to a strong wind. During boom lift, consider that the rated lifting capacity is reduced by 50% when the wind speed is 20mph (9 m/s) to 27 mph (12 m/s); reduced by 70% when the wind speed is 27 mph (12 m/s) to 31 mph (14 m/s). If the wind speed is 31 mph (14 m/s) or over, stop operation. During jib lift, stop operation if the wind speed is 20 mph (9 m/s) or over.
7. Rated lifting capacities at load radius shall not be exceeded. Do not tip the crane to determine allowable loads.
8. Do not operate at boom lengths, radii, or boom angle, where no capacities are shown. Crane may overturn without any load on the hook.
9. When boom length is between values listed, refer to the rated lifting capacities of the next longer and next shorter booms for the same radius. The lesser of the two rated lifting capacities shall be used.
10. When making lifts at a load radius not shown, use the next longer radius to determine allowable capacity.
11. Load per line should not exceed 12,300lbs. (5,600kg) for main winch and auxiliary winch.

12. Check the actual number of parts of line with LOAD MOMENT INDICATOR(AML-C) before operation. Maximum lifting capacity is restricted by the number of parts of line of LOAD MOMENT INDICATOR(AML-C). Limited capacity is as determined from the formula, Single line pull for main winch 12,300lbs. (5,600kg) x number of parts of line.
13. The boom angle before loading should be greater to account for deflection. For rated lifting capacities, the loaded boom angle and the load radius is for reference only.
14. The 36.1' (11.0 m) boom length capacities are based on boom fully retracted. If not fully retracted [less than 49' (15.0 m) boom length], use the rated lifting capacities for the 49' (15.0 m) boom length.
15. Extension or retraction of the boom with loads may be attempted within the limits of the RATED LIFTING CAPACITIES. The ability to telescope loads is limited by hydraulic pressure, boom angle, boom length, crane maintenance, etc.
16. For lifting capacity of single top, deduct the weight of the load handling equipment from the rated lifting capacity of the boom. For the lifting capacity of single top, the net capacity shall not exceed 12,300 lbs. (5,600kg) including the main boom hook mass attached to the boom.
17. When the base jib or top jib or both jibs are removed, set the jib state switch to the REMOVED position.
18. When erecting and stowing jib, be sure to retain it by hand or by other means to prevent its free movement.
19. Use "ANTI-TWOBLOCK" disable switch when erecting and stowing jib and when stowing hook block. While the switch is pushed, the hoist does not stop, even when overwind condition occurs.
20. For boom length 141.1' (43.0 m) or less and 114.8' (35.0 m) or longer with jib, rated lifting capacities are determined by loaded boom angle only in the column headed "141.1' (43.0 m) boom + jib". For boom length 114.8' (35.0 m) or less with jib, rated lifting capacities are determined by loaded boom angle only in the column headed "114.8' (35.0 m) boom + jib". For angles not shown, use the next lower loaded boom angle to determine allowable capacity. (telescoping MODE I) For boom length 141.1' (43.0 m) or less and 128.0' (39.0 m) or longer with jib, rated lifting capacities are determined by loaded boom angle only in the column headed "141.1' (43.0 m) boom + jib ". For boom length 128.0' (39.0 m) or less with jib, rated lifting capacities are determined by loaded boom angle only in the column headed "128.0' (39.0 m) boom + jib". For angles not shown, use the next lower loaded boom angle to determine allowable capacity. (telescoping MODE II)
21. When lifting a load by using jib (aux. winch) and boom (main winch) simultaneously, do the following:
 - Enter the operation status as jib operation, not as boom operation.
 - Before starting operation, make sure that mass of load is within rated lifting capacity for jib.
22. Before telescoping the boom, set the telescoping mode selector switch to MODE I or MODE II with the boom fully retracted. A change of the telescoping mode is not permissible when the boom has been partially or fully extended.
23. Crane operation is prohibited without full counterweight 12,600lbs. (5.7 ton) installed. Outriggers shall be extended 23'11 3/8" (7.3 m) spread when installing or removing removable counterweight.

DEFINITIONS

1. Load Radius: Horizontal distance from a projection of the axis of rotation to supporting surface before loading to the center of the vertical hoist line or tackle with load applied.
2. Loaded Boom Angle: The angle between the boom base section and the horizontal, after lifting the rated lifting capacity at the load radius.
3. Working Area: Area measured in a circular arc about the centerline of rotation.
4. Freely Suspended Load: Load hanging free with no direct external force applied except by the hoist line.
5. Side Load: Horizontal side force applied to the lifted load either on the ground or in the air.

NOTES FOR ON RUBBER LIFTING CAPACITIES

1. Rated lifting capacities on rubber are in pounds and do not exceed 75% of tipping loads as determined by SAE J765-Crane Stability Test Code.
2. Rated lifting capacities shown in the chart are based on condition that crane is set on firm level surfaces with suspension-lock applied. Those above thick lines are based on tire capacity and those below, on crane stability. They are based on actual load radius increased by tire deformation and boom deflection.
3. If the suspension-lock cylinders contain air, the axle will not be locked completely and rated lifting capacities may not be obtainable. Bleed the cylinders according to the operation safety and maintenance manual.
4. Rated lifting capacities are based on proper tire inflation, capacity and condition. Damaged tires are hazardous to safe operation of crane.
5. Tires shall be inflated to correct air pressure.

Tires	Air pressure
29.5-25 22 PR	60 psi. (420 kPa)
29.5-25 28 PR	64 psi. (450 kPa)

6. Over front operation shall be performed within 2 degrees in front of chassis.
7. On rubber lifting with "jib" is not permitted. Maximum permissible boom length is 88.6 ft. (27.0 m).
8. When making lift on rubber stationary, set parking brake.
9. For creep operation, boom must be centered over front of machine, swing lock engaged, and load restrained from swinging. Travel slowly and keep the lifted load as close to the ground as possible, and especially avoid any abrupt steering, accelerating or braking.
10. Do not operate the crane while carrying the load.
11. Creep is motion for crane not to travel more than 200 ft. (60m) in any 30 minute period and to travel at the speed of less than 1 mph (1.6km/h).
12. For creep operation, choose the drive mode and proper gear according to the road or working condition.

The rated lifting capacity is the total mass of a lifted load and lifting devices such as rigging wire ropes and the hook block.

Values above the thick line in the table are based on the structural strength of the crane, and values below the thick line are based on the crane stability factor.

The load radius shows the values including deflection of boom and outriggers (tires) caused by lifting loads.

For actual operation, refer to the load radius that includes the deflections.

When you operate the crane with the boom length which is not shown in the rated lifting capacity table, read the rated lifting capacity display on the load moment indicator (AML).

When the boom length shown on the load moment indicator (AML) is not shown in the rated lifting capacity table, compare the rated lifting capacity shown on the load moment indicator (AML) and that specified for the boom length which is next longer in the table, and use the smaller rated lifting capacity as a guide.



**ON OUTRIGGERS FULLY EXTENDED 23' 11³/₈"(7.3 m) SPREAD
360° ROTATION** (Unit: lbs)

Load Radius in Feet	Boom Length in Feet											
	36.1' (11 m)		49.2' (15 m)		62.3' (19 m)				75.5' (23 m)			
8	72	150,000	77	90,000								
10	68	132,300	75	90,000	79	70,500	78	44,100				
12	64	117,100	72	90,000	77	70,500	76	44,100	79	44,100	79	44,100
15	59	98,000	68	90,000	73	70,500	73	44,100	77	44,100	77	44,100
20	48	75,600	62	75,100	69	69,600	69	44,100	73	44,100	73	44,100
25	33	60,000	54	59,400	64	59,100	63	44,100	69	44,100	69	43,300
30			46	45,900	59	45,000	58	44,100	65	44,100	65	37,200
35			36	33,900	52	32,900	52	38,300	60	34,600	60	32,400
40			21	26,100	45	25,300	45	30,200	55	26,800	55	28,500
45					38	19,900	38	24,600	50	21,300	50	24,800
50					29	15,900	28	20,500	45	17,300	45	20,700
55					13	11,100	11	14,000	38	14,200	38	17,500
60									31	11,700	31	15,000
65									22	9,700	22	13,000
70												
75												
80												
85												
A												

0°

The above diagram shows an example of rated lifting capacity tables. For the actual values, see the rated lifting capacity tables provided in your cab.

Metric ton Specifications (Option)

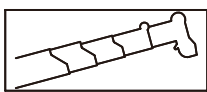

ON OUTRIGGERS FULL

(Unit: lbs)

Load Radius (m)	Boom length											
	11m(36.1')		15m(49.2')		19m (62.3')				23m (75.5')			
	⚡	⚡	⚡	⚡	⚡	⚡	⚡	⚡	⚡	⚡	⚡	
2.4	72	68.0	77	40.8								
3.0	68	60.7	75	40.8	79	32.0	78	20.0				
3.5	65	54.9	73	40.8	78	32.0	77	20.0	79	20.0	79	20.0
4.0	62	49.9	71	40.8	76	32.0	75	20.0	78	20.0	78	20.0
4.5	59	45.1	68	40.8	73	32.0	73	20.0	77	20.0	77	20.0
5.0	56	41.6	66	38.9	72	31.9	72	20.0	76	20.0	76	20.0
5.5	52	38.3	64	36.7	71	31.7	71	20.0	75	20.0	75	20.0
6.0	49	35.0	62	34.5	69	31.6	69	20.0	73	20.0	73	20.0
6.5	44	32.4	60	32.2	68	30.3	67	20.0	72	20.0	72	19.9
7.0	39	30.1	57	29.8	66	28.7	65	20.0	71	20.0	71	19.8
7.5	34	27.8	55	27.5	64	27.2	63	20.0	69	20.0	69	19.7
8.0	29	21.1	52	25.4	63	25.2	62	20.0	68	20.0	68	18.9
9.0			47	21.4	59	21.0	58	20.0	65	20.0	65	17.1
10.0			40	17.8	55	17.3	55	18.5	62	17.6	62	15.6
11.0			33	14.6	50	14.2	50	16.6	59	14.9	59	14.3
12.0			23	12.3	46	11.9	46	14.2	56	12.6	56	13.2
14.0					36	8.7	36	10.8	49	9.3	49	10.9
16.0					21	6.1	20	7.8	42	7.1	42	8.7
18.0									32	5.5	32	7.0
20.0									19	4.3	20	5.7
22.0												
24.0												
26.0												
28.0												

Rated lifting capacity based on crane structural strength

Thick line

Rated lifting capacity based on crane stability

K06228-00E

Outrigger Extending Status and Lifting Performance

With the outrigger maximum extension, the crane's capacity is the same throughout 360 degrees.

The rated lifting capacity in the side area changes depending on the extension width of outriggers. When a load is lifted on a side of larger extension width of outriggers and swung to a side of smaller extension width, the rated lifting capacity decreases. Be careful to avoid overloading.

Rated lifting capacities in front and rear areas are the same as the outrigger maximum extension capacity.

Depending on the extension width of outriggers, the ranges of front and rear areas are decreased as shown in the diagrams below.

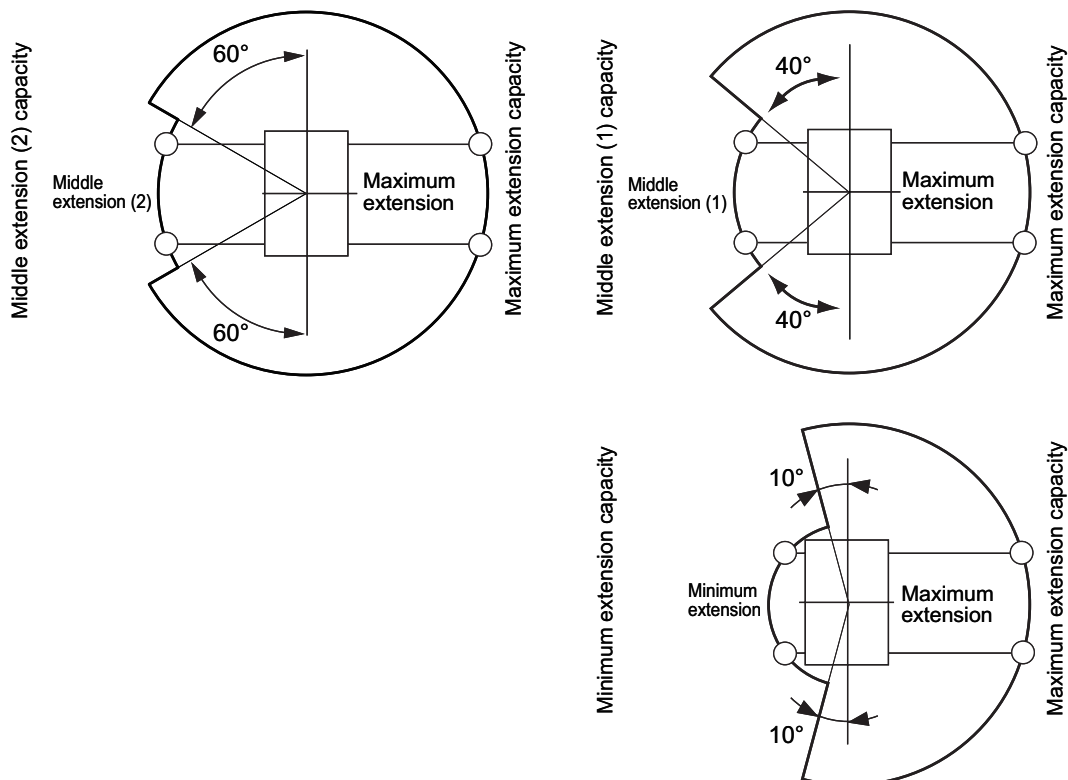

K02694-00E

 For details refer to the section "Extension Width of Outriggers and Working Area" (page 456).

Standard Number Parts of Line

⚠ WARNING

- If the crane is operated with more number of parts of line than the standard, the wire rope length can become insufficient. If the entire length of wire rope on the winch drum is reeled out, the load will be then applied to the end of the wire rope. This can break the wire rope and cause an accident. Or the wire rope can be wound up in the opposite direction. In this situation, the hook block is hoisted up during winch hoist-down operation. This also can cause an accident. Select the number of parts of line so that 3 or more dead turns of rope always remain on the winch drum.
- If the number of parts of line used is less than the standard, the load cannot be lifted as specified in the rated lifting capacity table. If a load heavier than the allowable load is lifted up, the wire rope can break and cause an accident. Make sure that the allowable load per one wire rope (12,300 lbs [5,600 kg] or less for both main and auxiliary wire ropes) is not exceeded.

G45012-00E

The standard number of parts of line in relation to the boom length is as shown below.

On-outrigger

Operation	Boom length				Jib lift	Single Top lift
	36.1 ft. (11 m)	36.1 ft. to 49.2 ft. (11 m to 15 m)	49.2 ft. to 62.3 ft. (15 m to 19 m)	62.3 ft. to 141.1 ft. (19 m to 43 m)		
Telescoping mode	I , II	I	I II	I , II	I , II	I , II
Standard number of parts of line	14	8	6 4	4	1	1

On-rubber

Operation		Boom length		Jib lift	Single Top lift
		36.1 ft (11 m)	36.1 ft to 88.6 ft (11 m to 27 m)		
Telescoping mode		I , II	II	-----	I , II
Standard number of parts of line	Capacity for over-front area	Stationary	6 4	-----	1
		Creeping	6 4	-----	1
	Capacity for 360-degree area	Stationary	6 4	-----	1
		Creeping	-----	-----	-----

Reduction of Rated Lifting Capacity

Boom Lift

The rated lifting capacities for boom lift assume that the jib is stowed in the specified position and the main winch is used. When the jib is attached to the boom end during boom lift, subtract the value in the table below from the rated lifting capacity.

Single Top Lift and Jib Lift

The rated lifting capacities for single top lift or jib lift assume that the main winch is used. If you perform single top lift or jib lift using the auxiliary winch, subtract the mass of the main hook block from the rated lifting capacity values.

WEIGHT REDUCTIONS FOR AUXILIARY LOAD HANDLING EQUIPMENT

Load Handling Equipment																
75ton,7Sheave Hook Block(See Hook Block for actual weight)										1,300 (lbs.)						
Aux.Hook(See Hook for actual weight)										330 (lbs.)						
Lifting from Main Boom with																
Base and/or Top Jib stowed on base boom														0 (lbs.)		
#1	Single Top stowed on top boom													0 (lbs.)		
	Single Top erected but not used													0 (lbs.)		Fig.1
	33.2'(10.1m)Base Jib erected but not used													(lbs.)		Fig.2
	Boom Length	36.1'	49.2'	62.3'		75.5'		88.6'		101.7'		114.8'		128.0'	141.1'	
	Telescoping Mode	I, I	I	I	I	I	I	I	I	I	I	I	I	I	I, I	
		18,100	12,400	10,500	7,600	7,800	7,500	7,700	6,800	6,800	6,100	5,900	5,300	5,100	4,900	
	33.2'(10.1m)Base Jib erected but not used + Aux.Hook on Base Jib													(lbs.)		Fig.3
	Boom Length	36.1'	49.2'	62.3'		75.5'		88.6'		101.7'		114.8'		128.0'	141.1'	
	Telescoping Mode	I, I	I	I	I	I	I	I	I	I	I	I	I	I	I, I	
		18,900	13,200	11,300	8,400	8,500	8,300	8,400	7,500	7,400	6,700	6,500	5,900	5,700	5,500	
	58.1'(17.7m)Base and Top Jib erected but not used													(lbs.)		Fig.4
	Boom Length	36.1'	49.2'	62.3'		75.5'		88.6'		101.7'		114.8'		128.0'	141.1'	
	Telescoping Mode	I, I	I	I	I	I	I	I	I	I	I	I	I	I	I, I	
		20,400	14,700	12,600	9,800	9,800	9,500	9,500	8,600	8,400	7,700	7,300	6,800	6,600	6,300	
	58.1'(17.7m)Base and Top Jib erected but not used + Aux.Hook on Top Jib													(lbs.)		Fig.5
	Boom Length	36.1'	49.2'	62.3'		75.5'		88.6'		101.7'		114.8'		128.0'	141.1'	
	Telescoping Mode	I, I	I	I	I	I	I	I	I	I	I	I	I	I	I, I	
		21,700	15,900	13,800	11,000	10,900	10,600	10,500	9,600	9,300	8,600	8,200	7,600	7,400	7,100	
Lifting from 33.2'(10.1m)Base Jib with																
24.9'(7.6m)Top Jib erected but not used										Prohibited						
24.9'(7.6m)Top Jib stowed on 33.2'(10.1m)Base Jib										Prohibited						

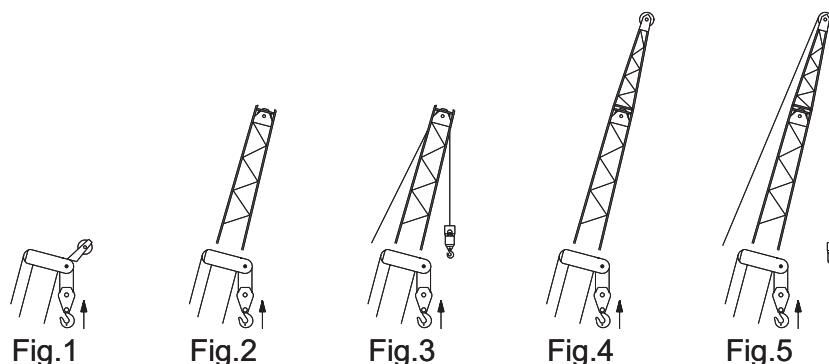

- Note
- * Capacity deductions are for TADANO supplied equipment only.
 - * When lifting from Jib, deduct total weight of all load handling devices reeved on Main Boom nose directly from Jib capacity. (#2)
- #1. Correct state of Jib, equipped or removed, should be inputted into the LOAD MOMENT INDICATOR(AML-C) by Jib state key switch.
 - #2. The winch which is lifting load should be defined in the LOAD MOMENT INDICATOR(AML-C) by main winch/auxiliary winch selector switch.

Metric ton Specifications (Option)

WEIGHT REDUCTIONS FOR AUXILIARY LOAD HANDLING EQUIPMENT

Load Handling Equipment	
68ton,7Sheaves Hook Block(See Hook Block for actual weight)	0.59 (ton)
Aux.Hook(See Hook for actual weight)	0.15 (ton)

Lifting from Main Boom with			
Base and/or Top Jib stowed on base boom		0 (ton)	
#1	Single Top stowed on top boom	0 (ton)	
	Single Top erected but not used	0 (ton)	
	10.1m(33.2')Base Jib erected but not used		Fig.1
	(ton)		
	Boom Length	11m 15m 19m 23m 27m 31m 35m 39m 43m	Fig.2
Telescoping Mode	I, II I I II I II I II I II I II I, II		
	8.18 5.58 4.73 3.43 3.51 3.40 3.45 3.06 3.05 2.74 2.64 2.39 2.31 2.22		
10.1m(33.2')Base Jib erected but not used + Aux.Hook on Base Jib		(ton)	
Boom Length	11m 15m 19m 23m 27m 31m 35m 39m 43m	Fig.3	
Telescoping Mode	I, II I I II I II I II I II I II I, II		
	8.57 5.97 5.09 3.79 3.85 3.74 3.77 3.37 3.34 3.03 2.91 2.65 2.58 2.47		
17.7m(58.1')Base and Top Jib erected but not used		(ton)	
Boom Length	11m 15m 19m 23m 27m 31m 35m 39m 43m	Fig.4	
Telescoping Mode	I, II I I II I II I II I II I II I, II		
	9.24 6.63 5.69 4.41 4.41 4.30 4.27 3.88 3.78 3.47 3.31 3.05 2.97 2.83		
17.7m(58.1')Base and Top Jib erected but not used + Aux.Hook on Top Jib		(ton)	
Boom Length	11m 15m 19m 23m 27m 31m 35m 39m 43m	Fig.5	
Telescoping Mode	I, II I I II I II I II I II I II I, II		
	9.83 7.21 6.23 4.96 4.92 4.80 4.73 4.33 4.19 3.88 3.68 3.42 3.34 3.18		
Lifting from 10.1m(33.2')Base Jib with			
7.6m(24.9')Top Jib erected but not used		Prohibited	
7.6m(24.9')Top Jib stowed on 10.1m(33.2')Base Jib		Prohibited	

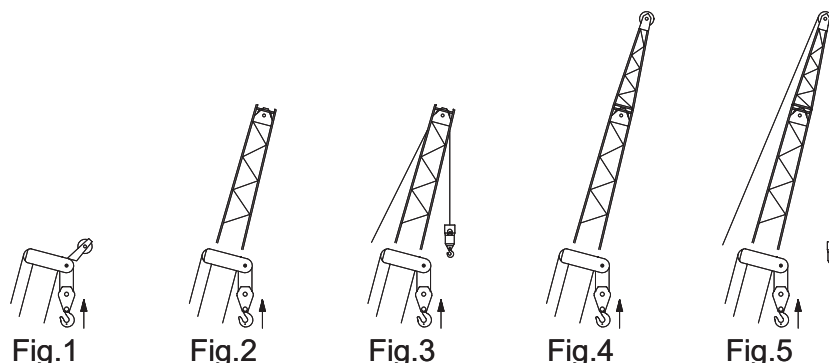

- Note**
- * Capacity deductions are for TADANO supplied equipment only.
 - * When lifting from Jib, deduct total weight of all load handling devices reeved on Main Boom nose directly from Jib capacity. (#2)
 - #1. Correct state of Jib, equipped or removed, should be inputted into the LOAD MOMENT INDICATOR(AML-C) by Jib state key switch.
 - #2. The winch which is lifting load should be defined in the LOAD MOMENT INDICATOR(AML-C) by main winch/auxiliary winch selector switch.

343-988-21010-0
343-984-31900-0 K06229-00E

Load Moment Indicator (AML)

⚠ WARNING

Never operate the crane with the automatic stop function of the load moment indicator canceled. If you use the load moment indicator incorrectly, the machine can overturn or suffer damage, and cause a fatal injury.

NOTICE

Set the override key switch to "OFF", and pull out the keys from the key holes. The person having supervisory or management duties for the machine or the work shall keep the keys.

The load moment indicator calculates the working moment and rated moment based on the operation status registered by the operator and input signal from each detector, and displays them as a moment load ratio. When the moment load ratio reaches or exceeds 100%, the load moment indicator stops the crane operations toward the critical sides and warns with error codes and buzzer.

The load moment indicator is a safety device to prevent accidents such as machine overturning and damage caused by overload, and is not a load meter. The shown lifting loads are reference values, and their precision is not guaranteed.

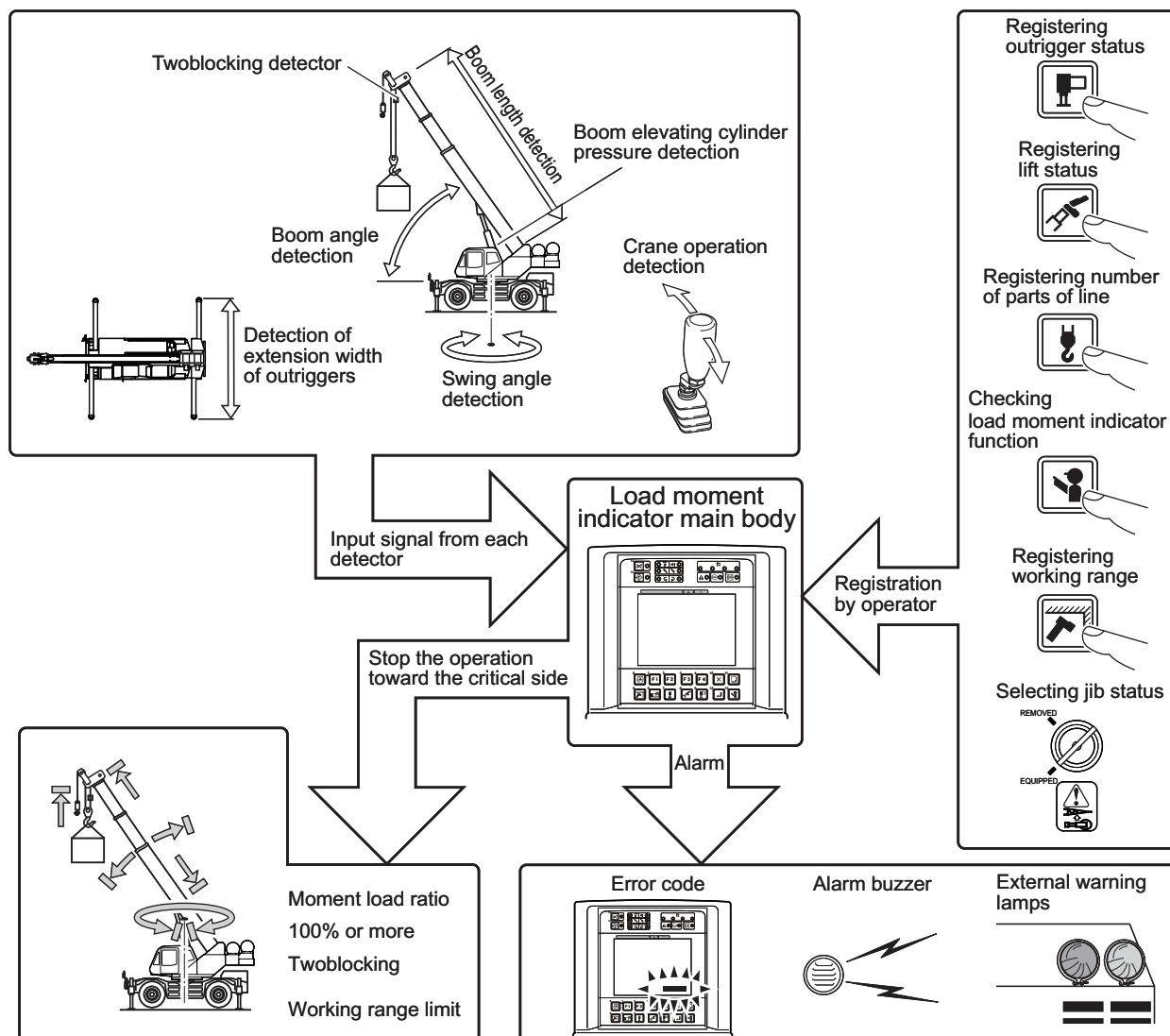

GR-750XL-2_OM2(U)-17E

K02983-01E

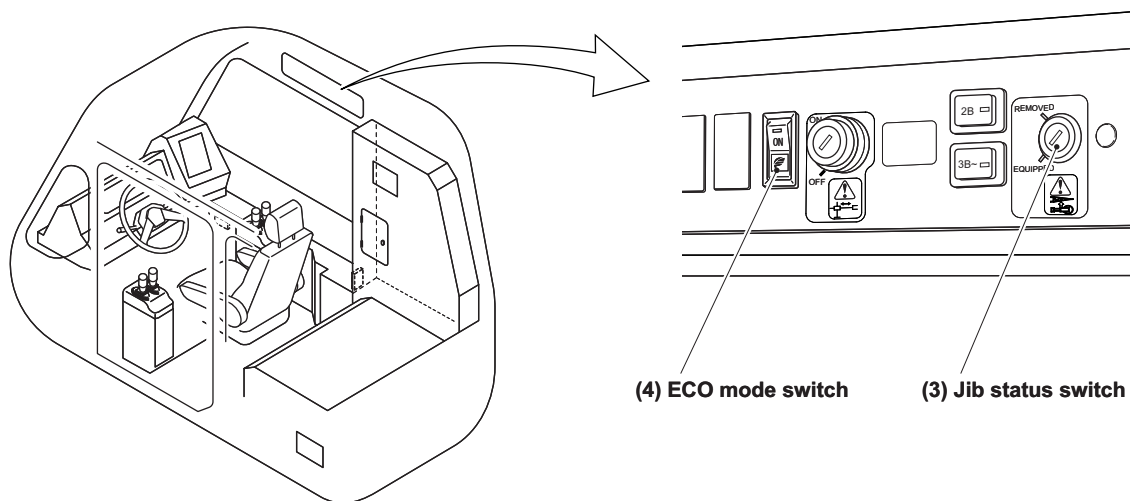
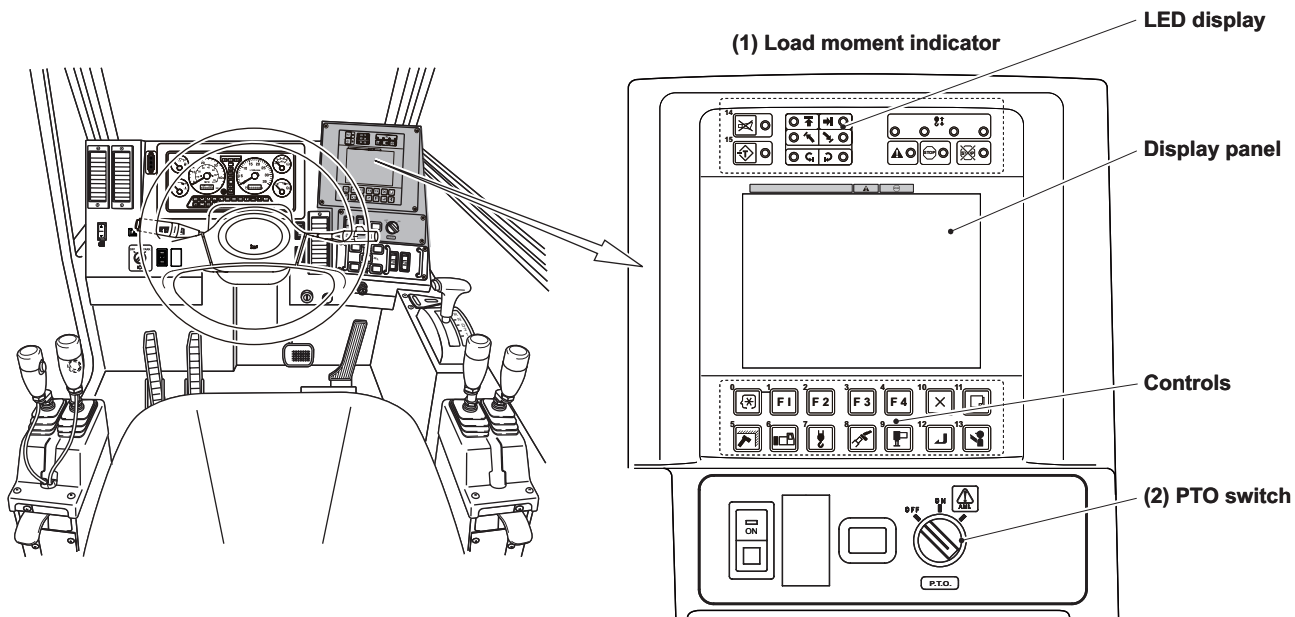

K07029-00E

(1) Load moment Indicator

The load moment indicator consists of the LED display, Display panel, and Controls.

The LED display shows the presence of each working range limit, turning condition of the winch drums, and condition of the load moment indicator function.

The display panel shows the moment load ratio, crane state, outrigger state, swing position, and error code.

(2) PTO switch

When this switch is set to "ON", the load moment indicator is turned on.

(3) Jib Status Switch

Register the jib state (mount or dismount) using the Jib Status Switch.

(4) ECO Mode Switch

While the ECO Mode Switch is on, the maximum engine speed of the crane operation is restricted and noise of the crane operation is controlled.

How to Read the Indication

Display Panel

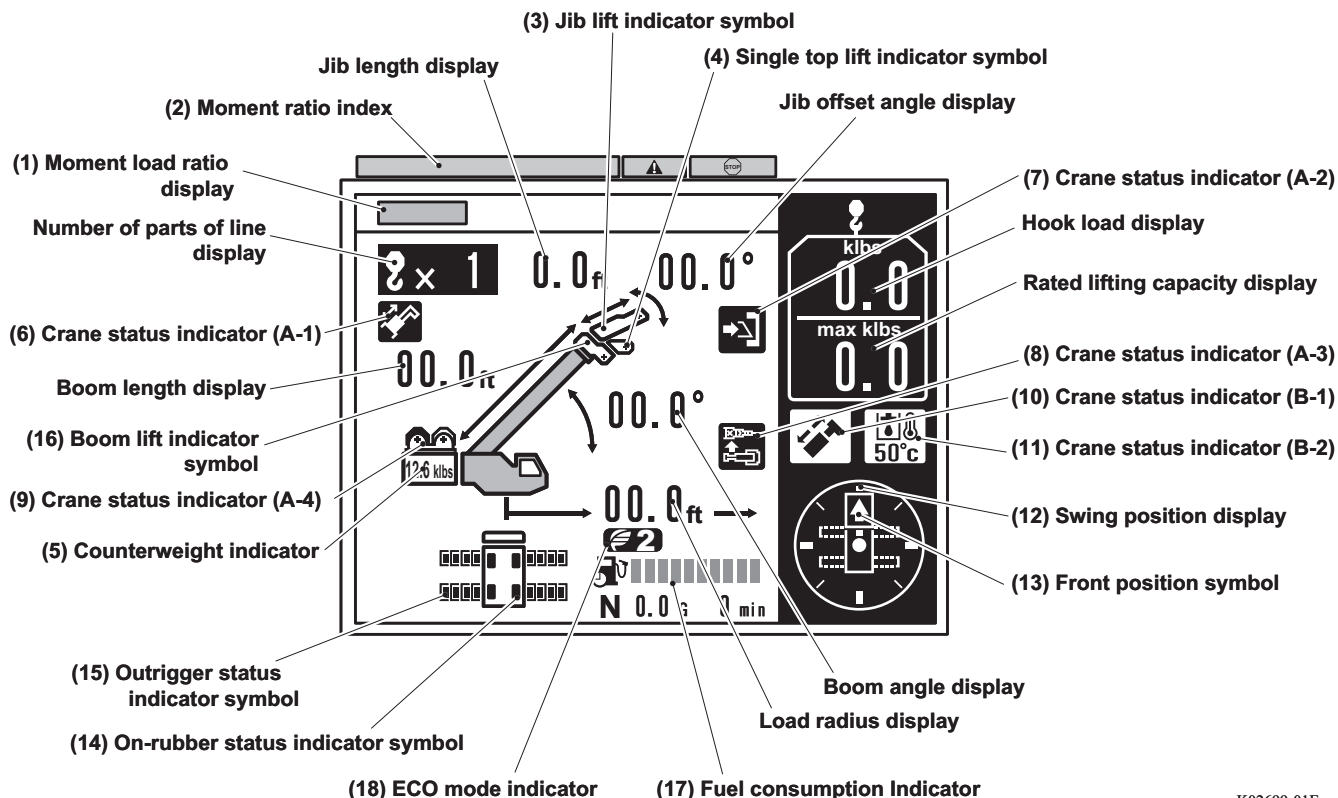

K02699-01E

NOTICE

- Moment load ratio is not a ratio of the hook load to the rated lifting capacity. Find the correct hook load from the rated lifting capacity.
- The load moment indicator (AML) is not a hook load indicator. The hook load indication is a reference value, and not a correct mass of the lifted load.

Moment load ratio

≠

Hook load

Rated lifting capacity

K03064-00E

(1) Moment load ratio display

Shows the moment load ratio with a bar graph.

(2) Moment load ratio index

Serves as an index how critical the moment load ratio represented by the bar graph is; safe (green), warning (yellow), or critical (red).

(3) Jib lift indicator symbol

Appears when the jib lift is registered. Flashes when the jib set state is registered to the load moment indicator.

(4) Single top lift indicator symbol

Appears when the single top lift is registered.

(5) Counterweight indicator

Indicates the state of the mounted counterweight.

(6) Crane status indicator (A-1)**(7) Crane status indicator (A-2)****(8) Crane status indicator (A-3)****(9) Crane status indicator (A-4)****(10) Crane status indicator (B-1)****(11) Crane status indicator (B-2)**

The indicator (icon) shows a crane state. Refer to "Crane Status Indicator" (page 145) for the meaning of the icons.

(12) Swing position display

Shows the current swing position. The display is graduated in 45°.

(13) Front position symbol

Appears when the boom is directed to the front of the vehicle.

(14) On-rubber status indicator symbol

Flashes during on-rubber creep operation, and turns on steadily during on-rubber stationary operation.

(15) Outrigger status indicator symbol

Indicates the extension width of outriggers. The outer frames of the symbol represent the maximum available steps of the outrigger extension, and the inner frames (black-filled segments) represent the current step of outrigger extension.

(16) Boom Lift Indicator Symbol

Appears when the boom lift is registered to the load moment indicator (AML).

(17) Fuel consumption indicator

The fuel consumption rate during crane operation is indicated.

(18) ECO mode indicator

Lights up when ECO mode switch is on and displays current mode such as ECO mode 1 or ECO mode 2.

LED Display

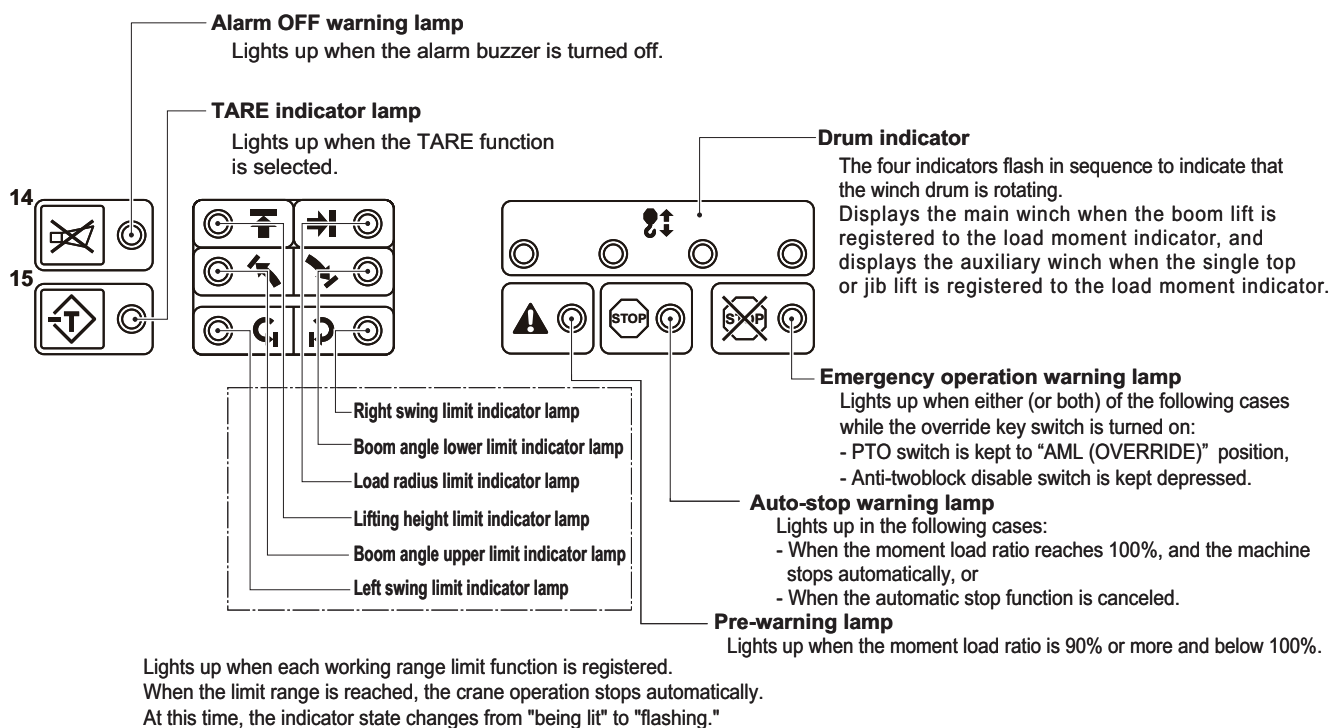

K01245-01E

Controls

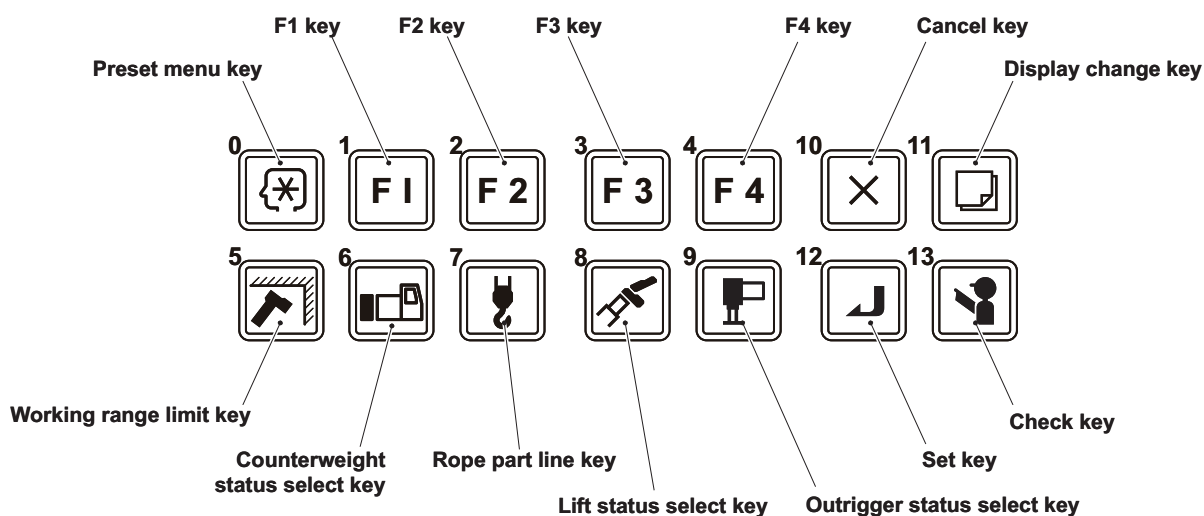

K04505-00E

GR-750XL-2_OM2(U)-17E

Selecting the Display

When the display change key is pushed, the content in the display panel changes as shown in the illustration.

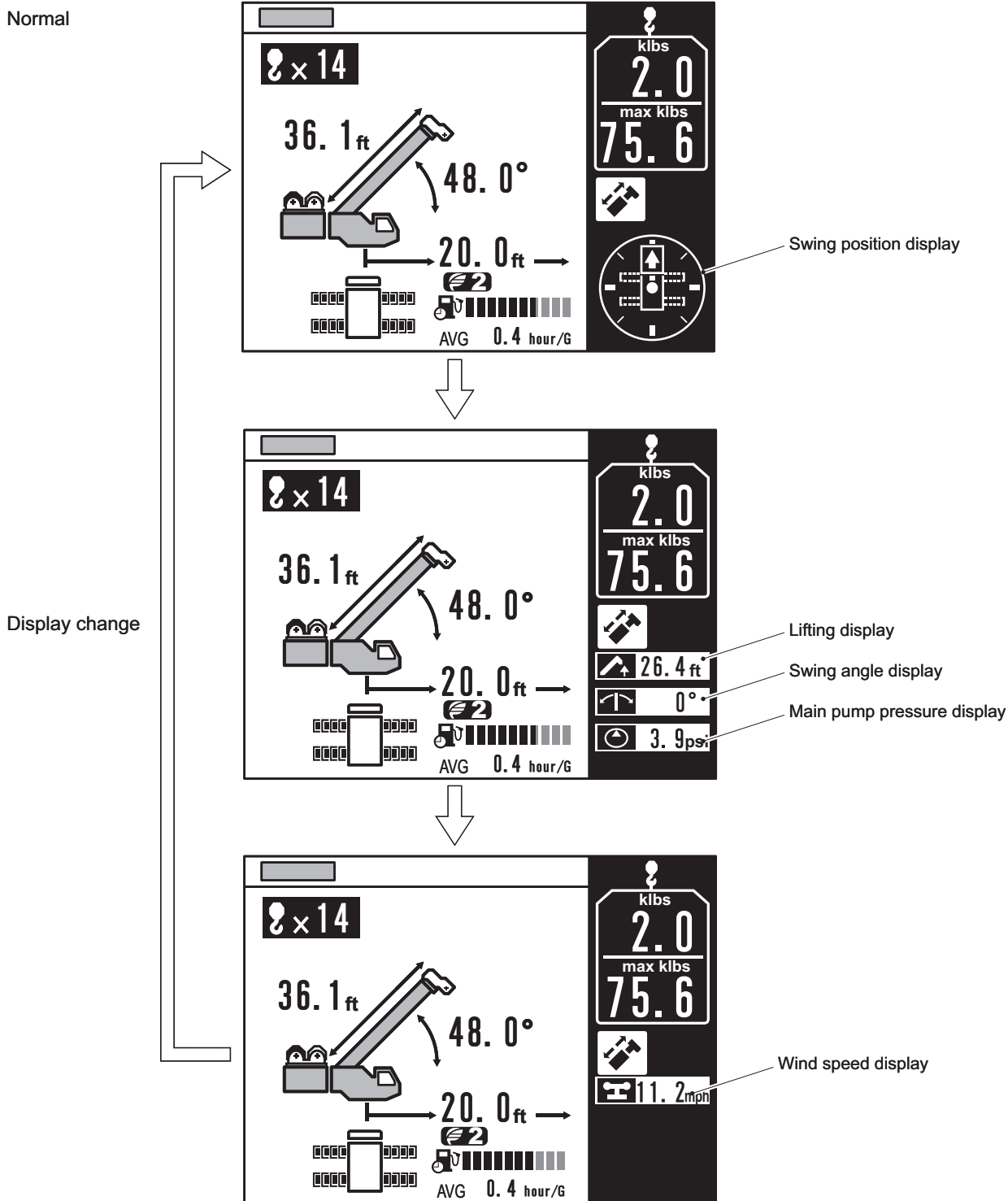







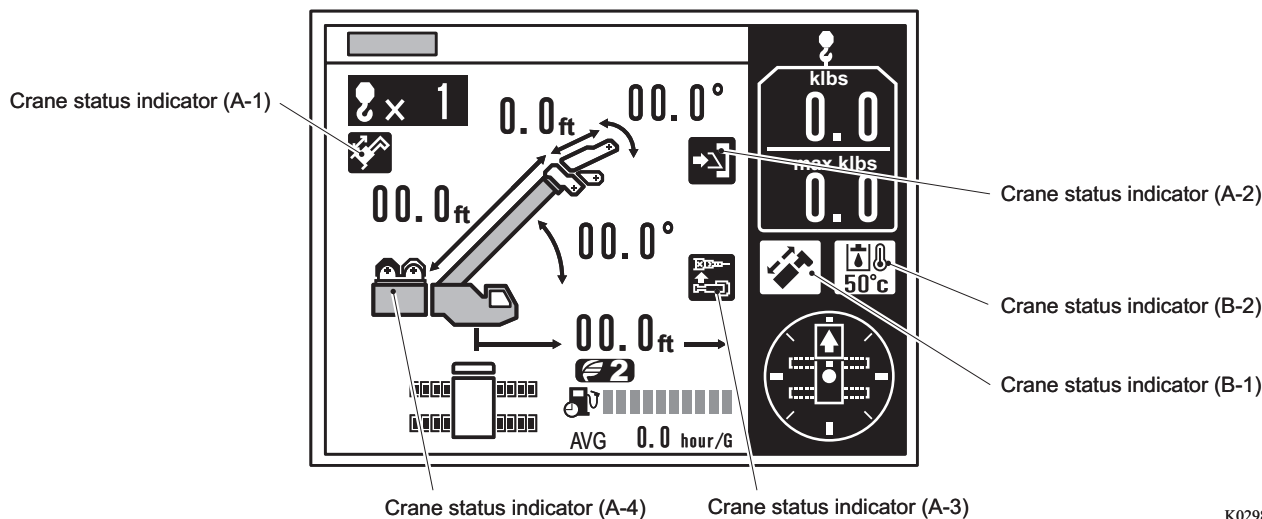

K02984-02E

Crane Status Indicator





The crane state is displayed by the indicators (icons). The positions and contents of the indicators are as follows.



K02985-02E

Icon	Designation	Position	Display condition
 K01824-000	Telescoping mode I	A-1	The boom telescoping mode I is selected.
 K01825-000	Telescoping mode II	A-1	The boom telescoping mode II is selected.
 K00734-010	Jib lock	A-2	Under the jib set state, the jib extension/retraction switch is set to "Ext". and the jib offset cylinder is fully extended.
 K01826-000	Jib dismount	A-3	The jib is dismounted from the boom, and the jib status switch is set to "REMOVED".
 K01828-000	Winch selection (Main winch)	A-4	The main winch is selected.
 K01827-000	Winch selection (Auxiliary winch)	A-4	The auxiliary winch is selected during single top lift or jib lift.
 K00737-010	Boom telescoping control	B-1	The boom telescoping/auxiliary hoist control selector switch is set to "Boom telescoping".
 K01829-000	Auxiliary Winch Control	B-1	The boom telescoping/auxiliary hoist control selector switch is set to "Auxiliary winch".

GR-750XL-2_OM2(U)-17E

Icon	Designation	Position	Display condition
 K00739-010	Hydraulic oil temperature 50°C	B-2	Flashes when the hydraulic oil temperature is between 122°F to 185°F (50°C to 85°C). (If more than one icon are to appear in this area, they appear alternately at each 3 seconds.)
 K00740-010	Hydraulic oil temperature 85°C	B-2	Flashes when the hydraulic oil temperature exceeds 185°F (85°C). (If more than one icon are to appear in this area, they appear alternately at each 3 seconds.)
 K00741-000	Outrigger switch out of neutral	B-2	Flashes when the extend/retract selector switch or jack/slide selector switch is set to the positions other than neutral position. (If more than one icon are to appear in this area, they appear alternately at each 3 seconds.)
 K01830-000	Outrigger state emergency registration	B-2	Flashes when the emergency outrigger control switch is set to "ON". (If more than one icon are to appear in this area, they appear alternately at each 3 seconds.)

Registration of Operating State and Load Moment Indicator (AML) Function Check

⚠ WARNING

Before you start the crane operation, make sure that correct operation state is registered and the load moment indicator (AML) system functions normally. If you register the operation state incorrectly or the load moment indicator (AML) system does not operate normally, the machine can overturn or suffer damage, and this can cause a fatal injury.

Before the crane operation, observe the steps below to register the operation state and be sure to do the load moment indicator (AML) function check.

1. Set the PTO switch to "ON".
 - The PTO indicator lights up, and the power is supplied to the load moment indicator (AML).

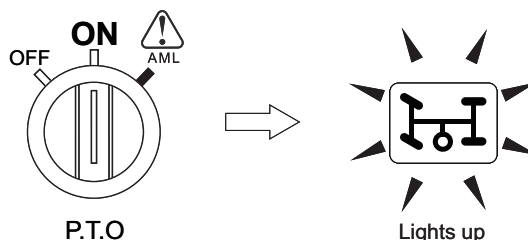

K01262-00E

2. Set up the outriggers.
3. Push the counterweight status select key.
 - The pop-up window for counterweight state registration appears on the display panel.

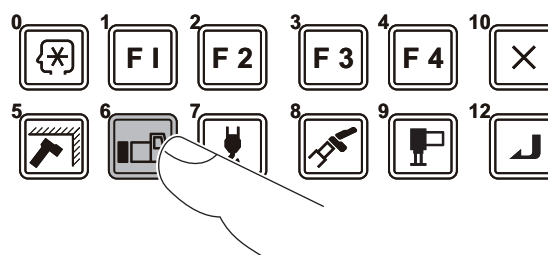

K02531-000

4. Check that the value of the counterweight indicated on the load moment indicator agrees with the actual crane state.

⚠ WARNING

If the indication on the load moment indicator and actual counterweight state does not agree, an overturning accident or a crane damage can occur.

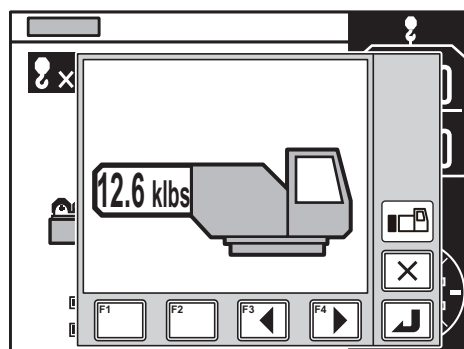

K02923-000

5. Push the set key to register the setting.
 - After the registration is completed, the pop-up window closes, and the load moment indicator returns to the crane operation state.

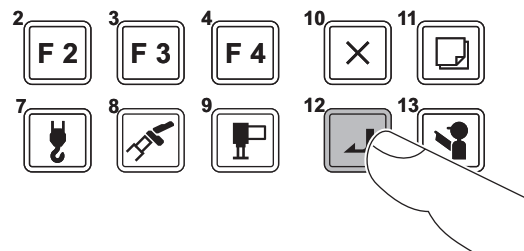

K00678-000

6. Push the outrigger status select key.
 - The pop-up window for the outrigger state registration is shown on the display panel. Each time the outrigger status select key is pushed, the display changes as shown below.

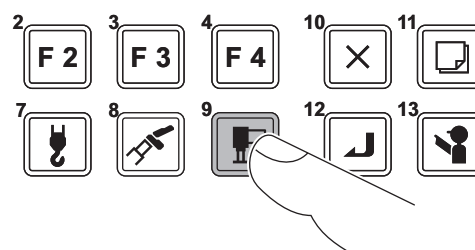

K00675-000

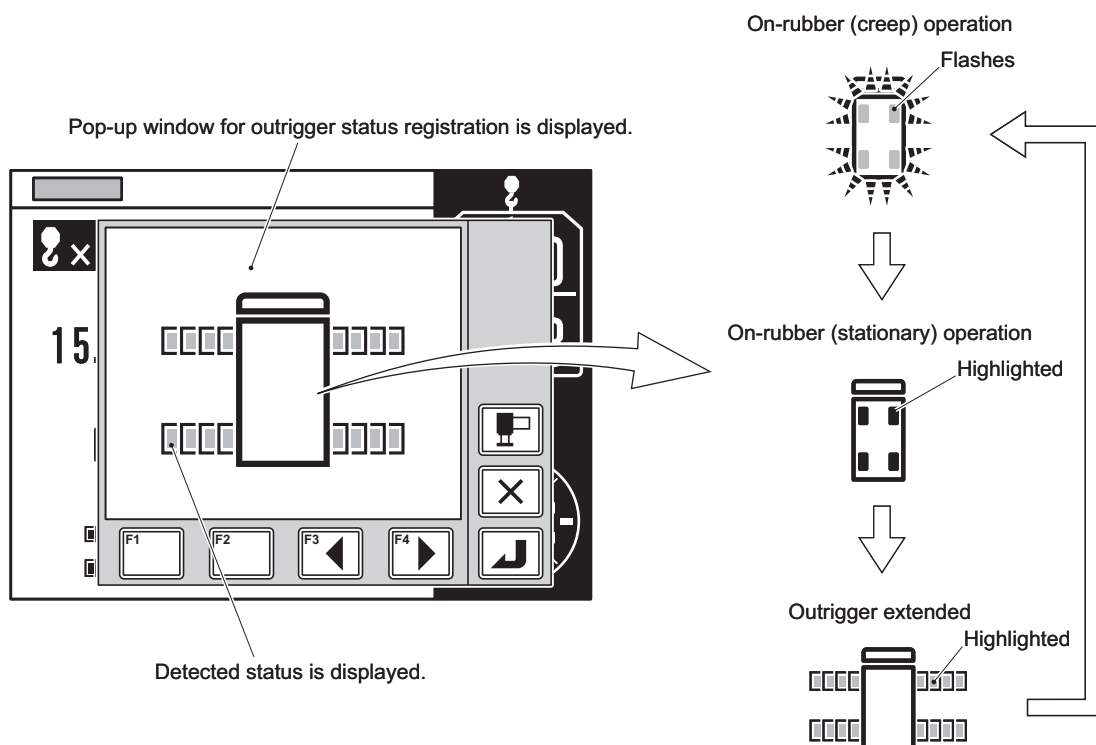

K01734-01E

- ☞ When the power for the load moment indicator is turned on, the "On-rubber (stationary) operation" state is automatically set.
- ☞ Instead of the outrigger status select key, you can use the F3 (Backward) key or F4 (Forward) key to change the display of the outrigger state.

7. Make sure that the display agrees with the actual outrigger state.
- The meanings of each indication of the outrigger state symbol are as shown in the illustration on the right.

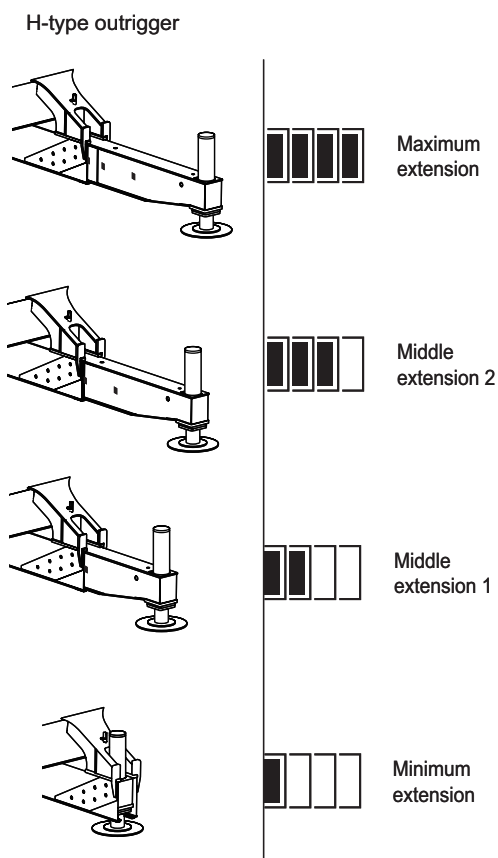

K03159-00E

When you want to stop registration, push the cancel key. The pop-up window closes and the load moment indicator returns to the state before start of the registration.

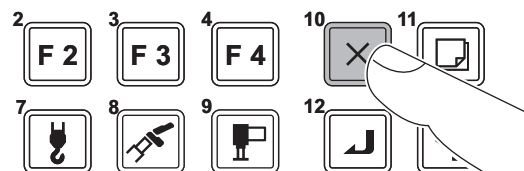

K00680-000

8. If the display agrees with the actual condition, push the set key to register the state.
 - After registration is completed, the pop-up window closes and the load moment indicator returns to the crane operation state.

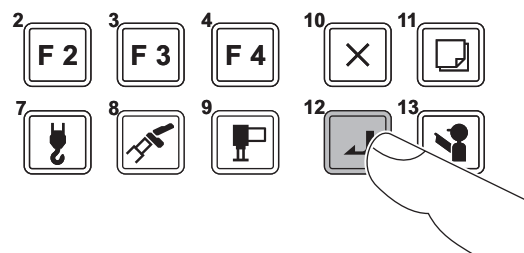

K00678-000

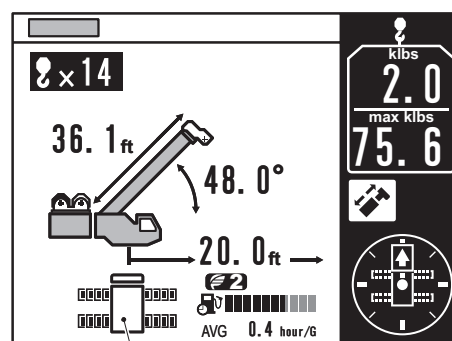
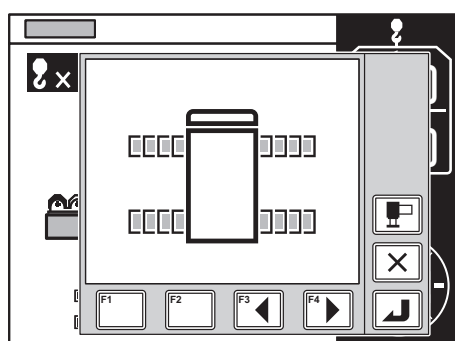

Outrigger status indicator symbol represents the registered status.

K02986-01E

9. Take out the main and auxiliary hook blocks from the stowing positions.

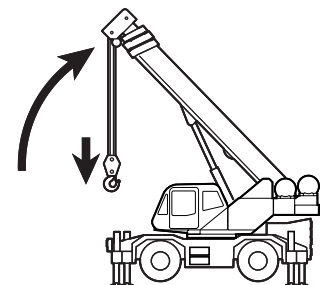

K02822-000

10. Push the lift status select key to register the lift state (single top/jib/boom).

- The pop-up window for the lift status registration is shown on the display panel. Every time the lift status select key is pushed, the display changes as shown below.

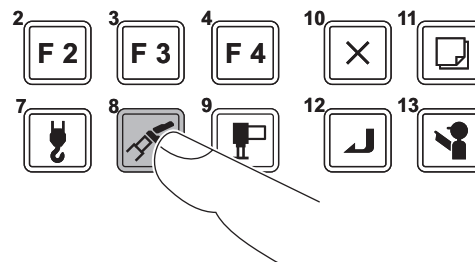

Pop-up window for lift status registration is displayed.

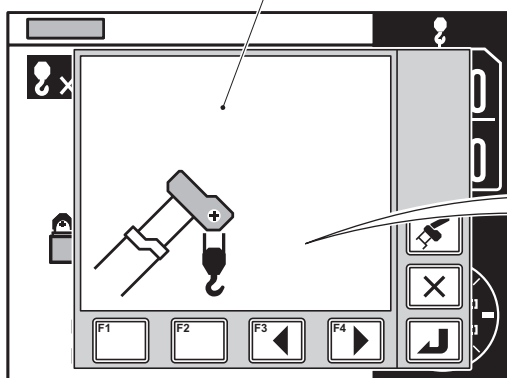

K00681-000

Pop-up window	Lift status
	Boom lift
	Single top lift
	Jib set
	33.2 ft. (10.1 m) jib lift, 3.5° offset
	33.2 ft. (10.1 m) jib lift, 25° offset
	33.2 ft. (10.1m) jib lift, 45° offset
	58.1 ft. (17.7 m) jib lift, 3.5° offset
	58.1 ft. (17.7 m) jib lift, 25° offset
	58.1 ft. (17.7 m) jib lift, 45° offset

K02987-03E

- ☞ When the power of the load moment indicator is turned on, the boom lift state is automatically set.
- ☞ Instead of the lift status select key, you can use the F3 (Backward) key or F4 (Forward) key to change the display of the lift state.

☞ When you want to stop registration, push the cancel key. The pop-up window closes and the load moment indicator returns to the state before start of the registration.

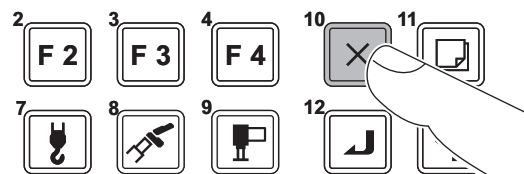

K00680-000

11. Push the set key.

- When the booms are fully retracted, the pop-up window for boom telescoping mode selection appears on the display panel.

☞ When a boom is extended, the boom telescoping modes cannot be selected.

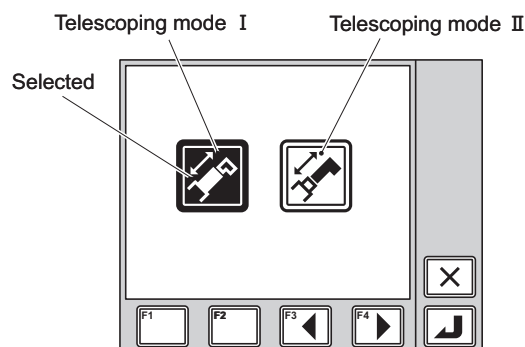

K01838-01E

12. Push the F3 (Backward) or F4 (Forward) key to select one of the telescoping mode icons.

- The selected icon is highlighted.

13. Push the set key to register the setting.

- After registration is completed, the pop-up window closes and the load moment indicator returns to the crane operation state.

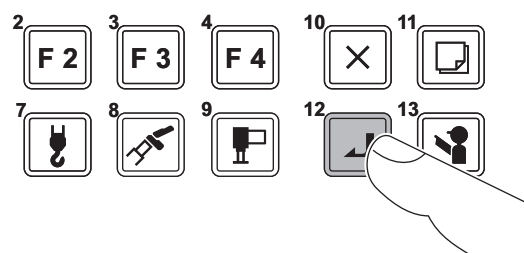

K00678-000

Lift status indication symbol represents the registered status.

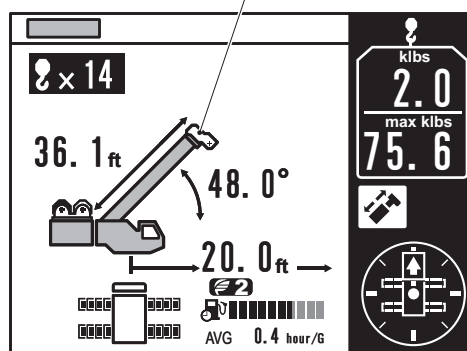
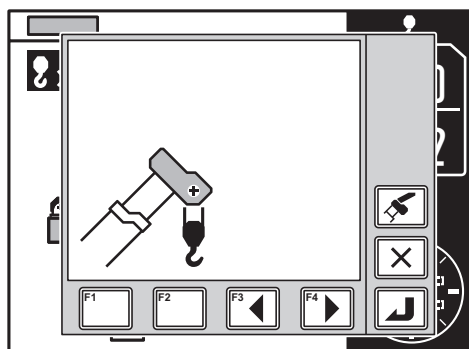

K02988-01E

- 14.** Push the rope part line key to register the number of parts of line to be used.
- The pop-up window for rope part line registration appears on the display panel. Each time you push the rope part line key, the number of parts of line changes.

The hook block is automatically selected and shown according to the registered lift state. If the displayed hook block symbol is not the one you want to register, push the F1 (main hook block) key to change the lift.

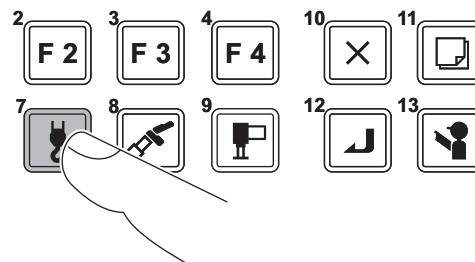

K00684-000

Pop-up window for main hook block registration is displayed.

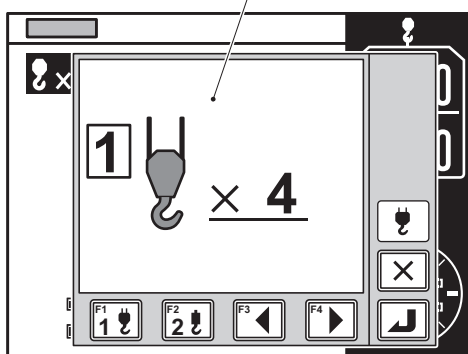

When boom lift is registered

Pop-up window for auxiliary hook block registration is displayed.

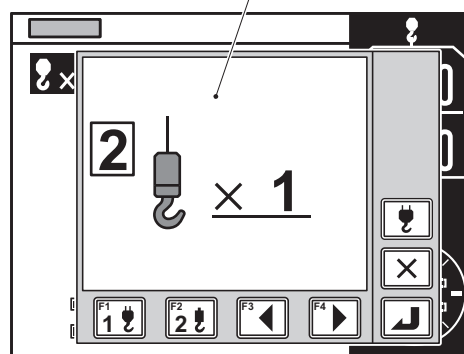

When single top/jib lift is registered

K03063-00E

- ☞ You can register only the number of parts of line specified for each model.
- ☞ Instead of the rope part line key, you can use the F3 (Backward) key or F4 (Forward) key to change the display of the number parts of line.
- ☞ When you want to stop registration, push the cancel key. The pop-up window closes and the load moment indicator returns to the state before the start of the registration.

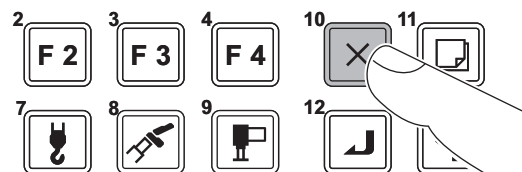

K00680-000

- 15.** Push the set key to register the setting.
- After registration is completed, the pop-up window closes and the load moment indicator returns to the crane operation state.

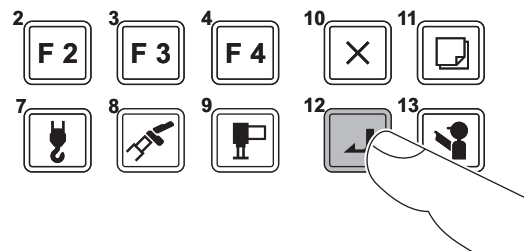

K00678-000

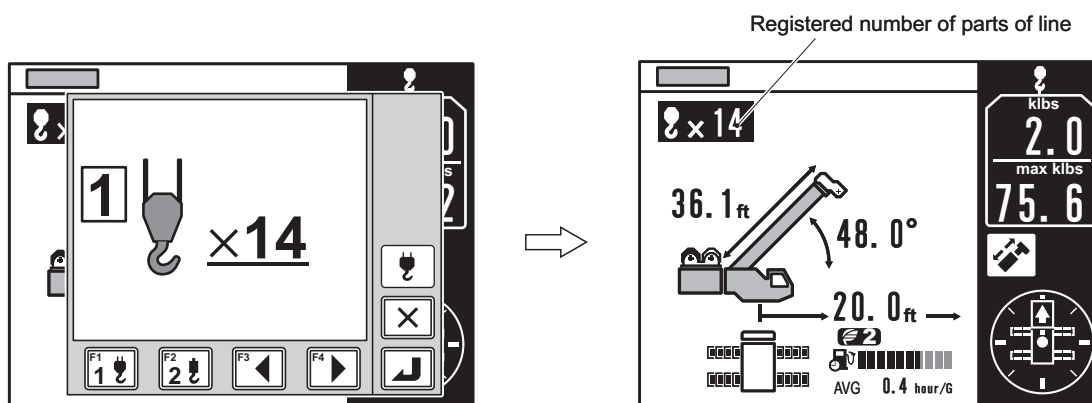

K02989-01E

- 16.** Set the jib status switch to register the jib state.
- REMOVED: Jib dismantled
 - EQUIPPED: Jib mounted
 - When the switch is set to "REMOVED", the jib dismantment icon appears on the display panel of the load moment indicator.

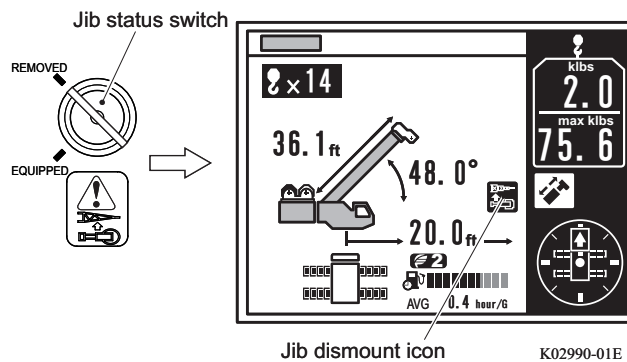

K02990-01E

WARNING

Make sure that the switch position corresponds to the actual jib mounting state. Otherwise, the calculation base of the load moment indicator is inaccurate, and the machine can overturn or be damaged.

☞ When the jib is dismantled, the reduction of the mass affects the measurement of the load moment indicator.

☞ You can insert/remove the switch key either in the "REMOVED" or "EQUIPPED" position.

17. Push the check key and make sure that the load moment indicator is in the condition below.

- LED Display: All lit
- Display Panel: All highlighted
- Alarm buzzer: Continuously sounds.

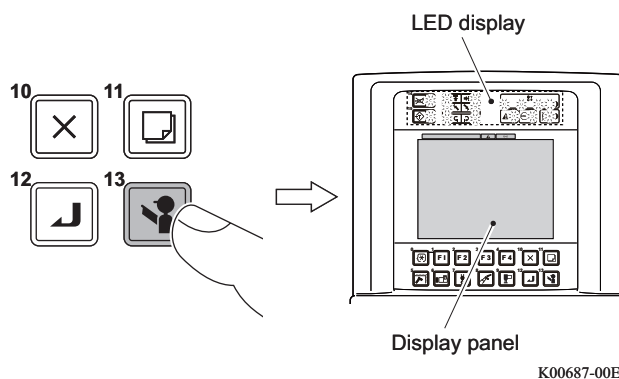

18. Attempt hoist-up, boom extension, boom raising, and boom lowering operations to make sure that the crane does not operate.

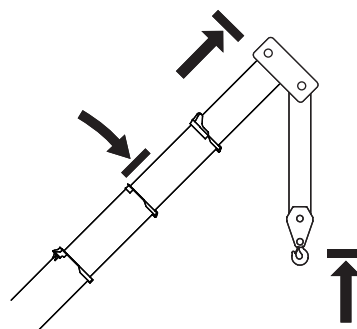

19. Push the check key again to return the load moment indicator to the crane operation state.

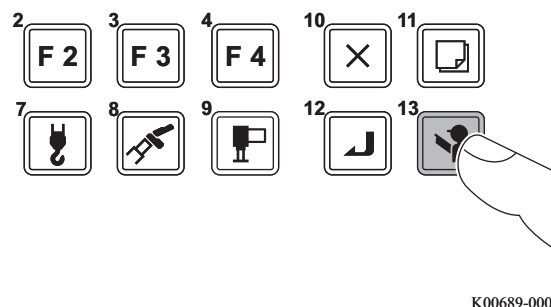

20. Make sure that the items on the display panel listed below agree with the actual state.

(1) Hook load

Make sure that approximate hook mass is shown under a no-load condition.

(2) Swing position display

(3) Front position symbol

(only when the boom is directed toward the front of the vehicle)

(4) Boom angle

(5) Outrigger status indicator symbol

(6) Boom length

(7) Number of parts of line

(8) Jib length (when jib lift is registered)

(9) Jib offset angle (when jib lift is registered)

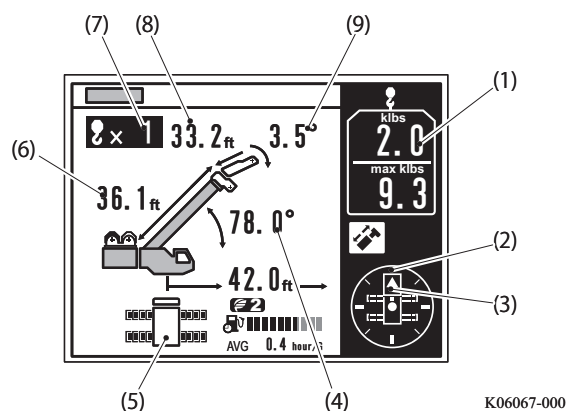

K06067-000

 The hook block mass shown varies depending on the crane configuration, etc.

Now, operation state registration and load moment indicator function check are completed.

You can start crane operation.

 Even after you turn off the load moment indicator, the registered information is retained for approximately 2 hours.

When the load moment indicator is turned on, the operation starts with the retained information. The registered information is erased approximately 2 hours after the load moment indicator is turned off. In this case, it is necessary to register the operation state from the beginning.

Alarm and Recovery Operation

NOTICE

Repair is necessary if any of the events below occurs:

- An error code other than given here is shown
 - The error code remains even after you register the state that corresponds to the error code or perform the recovery operation.
 - The crane stops and you cannot operate it
- Contact your nearest TADANO distributor or dealer.

When any failure occurs or improper operation is performed during crane operation, the buzzer sounds and an error code is shown to ensure safety and to prevent damage to the machine. Examine the contents of the error code, and perform the recovery operation.

Error Codes and Types of Buzzer

The error codes appear on the display panel.

There are 3 types of buzzers, and each buzzer sounds differently according to the cause of the alarm.

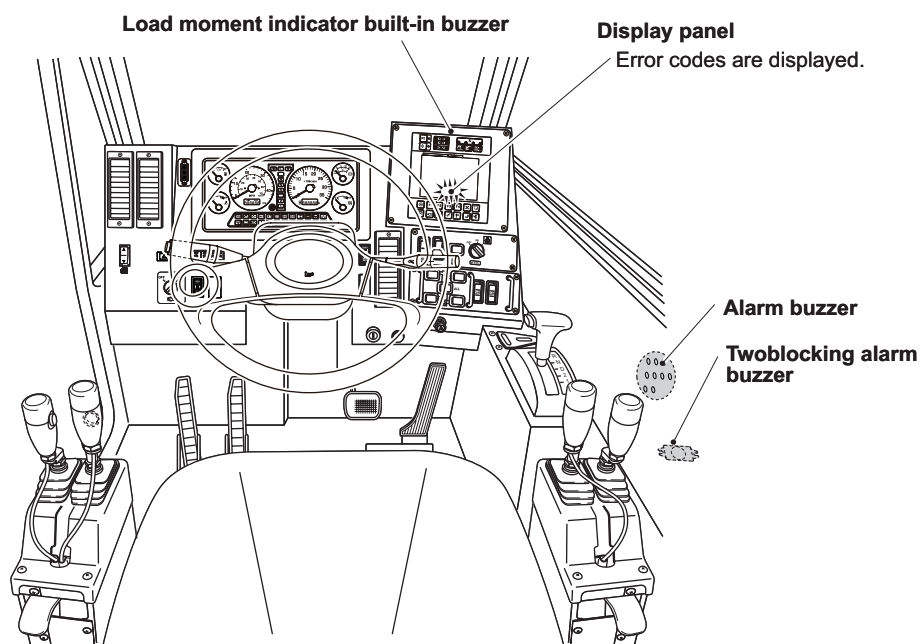

K07030-00E

Stop Alarm

Error code	Buzzer	Cause	Remedy
Ordinary bar graph display (no error code)  K00693-00	Alarm buzzer: Continuous sound	Moment load ratio is 100% or more.	Unwind the winch, retract or raise the boom, or swing to the non-critical side.
[W0023]		Crane is operated toward a critical side while the moment load ratio is 100% or more.	
[W0024]	Overwind (twoblocking) alarm buzzer: Tremolo sound	Crane is operated toward a critical side while the hook block is overwound.	Unwind the winch or retract the boom to lower the hook block.
[W0007]	load moment indicator built-in buzzer: beep-beep-beep (Every 1 second for 5 seconds.)	Overload occurs during the swing operation.	Swing in the opposite direction, or retract or raise the boom.
[W0025]		Backward stability decreases and the crane can overturn.	Lower or extend the boom.
[W0034]		Remaining wire rope on the main winch drum is short.	Wind up the winch.
[W0035]		Remaining wire rope on the auxiliary winch drum is short.	
[W0054]		Boom is lowered at elevation lower limit stroke end.	Raise the boom.
[W0055]		Boom is raised at elevation upper limit stroke end.	Lower the boom.
[W0121]		Boom is raised at elevation upper limit stroke end when the elevation slow stop is activated.	
[W0124]		Moment load ratio exceeds 80% during the boom lift with the jib extended.	<ul style="list-style-type: none"> • Unwind the winch, or retract or raise the boom. • Stow the jib.
[W0220]		The boom or the boom elevating cylinder may touch the engine cover.	Slew the boom in the opposite direction, or raise the boom.
[W0272]		Jib set status is registered to the AML and the boom is extended.	Retract the boom fully.

Warning Alarm

Error code	Buzzer	Cause	Remedy		
Ordinary bar graph display (no error code)  K00694-010	Alarm buzzer: Intermittent sound (Every 1.6 seconds)	Moment load ratio is 90% or more and less than 100%.	Carefully monitor the moment load ratio.		
[W0015]	Twoblocking alarm buzzer: Tremolo sound	The stop function is canceled with the anti-twoblock disabling switch while the hook block is overwound.	Unwind the winch or retract the boom to lower the hook block.		
[W0001]	Load moment indicator built-in buzzer: beep-beep-beep (Every 1 second for 5 seconds.)	Outrigger beams are retracted during crane operation	Extend the outrigger again, and insert the pin. Then, register the outrigger state again.		
[W0002]					
[W0003]		An outrigger beam retracts during crane operation, and the performance (lifting capacity) changes to the one with smaller extension width of outriggers.	Extend the outrigger again, and insert the pin. Then, register the outrigger state again.		
[W0004]					
[W0057]					
[W0058]					
[W0059]					
[W0060]					
[W0097]				Wind speed at the boom top or jib top exceeds the wind speed limit for crane operation.	Stow the boom and jib, and stop operation until wind speed becomes below the limit.
[W0013]				The state of front position detector switch and actual swing angle do not agree.	Contact your nearest TADANO distributor or dealer for inspection and maintenance.
[W0016]	<ul style="list-style-type: none"> Crane operation state goes out of the states that are registered to the load moment indicator. An operation state with no capacity rated is registered to the load moment indicator. 	<ul style="list-style-type: none"> Register the operation state again. For on-rubber operation, retract the boom to the capacity range. 			
[W0017]					
[W0018]					
[W0019]	The state of the boom full retraction detector switch and actual boom length do not agree.	Contact your nearest TADANO distributor or dealer for inspection and maintenance.			

Error code	Buzzer	Cause	Remedy
[W0041]	Load moment indicator built-in buzzer: beep-beep-beep (Every 1 second for 5 seconds.)	The state of the counterweight mounted on the crane does not agree with the state of registration on the load moment indicator.	<ul style="list-style-type: none"> Register the state of counterweight on the load moment indicator. Never operate a crane while counterweight is dismounted.
[W0056]		The outriggers are unequally extended, and further swing operation causes overloading.	Swing in the opposite direction, or retract or raise the boom.
[W0197]		When the boom (or jib) may touch the engine cover or the mirror.	Carefully lower or swing a boom.
[W0221]		The boom elevation or slewing operation is decelerating because the boom or the boom elevating cylinder is close to the engine cover.	Be careful when lowering or slewing the boom.
[W0286] (*1)		Operation levers are not in neutral positions when power is turned on.	Set all the operation levers in neutral positions. If the load moment indicator buzzer does not stop, contact your nearest TADANO distributor or dealer for inspection and maintenance.
[W0999]		When the power is turned on, the battery for the load moment indicator built-in clock is low.	Contact your nearest TADANO distributor or dealer for battery replacement.
[W0106]	Load moment indicator built-in buzzer: beep-beep-beep (Every 2 seconds.)	The elevation slow stop function is activated and boom elevating operation is decelerating.	The crane is approaching the stop position. Operate with care.
[W0108]		The swing stop function is activated and swing operation is decelerating.	

Error code	Buzzer	Cause	Remedy
[W0271]	<p>AML built-in buzzer: beep-beep-beep (Every 1 second for 5 seconds)</p> <p>Alarm buzzer: Intermittent sound (Every 0.4 seconds)</p>	<p>All conditions below has occurred at the same time.</p> <ul style="list-style-type: none"> - Jib set status or jib lift status is registered to the AML. - Boom is not fully retracted. - Boom angle is 10° or lower. 	<p>Before mounting/stowing the jib, fully retract the boom.</p>

(*1): For serial No. 548186 or later

Other Functions

There are other 6 functions as shown below.

- (1) Work range limit function
- (2) TARE Function
- (3) Fuel consumption display function
- (4) Mute Alarm Function
- (5) Preset menu (ECO mode selection, Winch drum rotation buzzer selection, Fuel consumption history display, Selection of the winch to be used, Adjustment of display panel contrast, Transmission of Telematics data, Setting of Anemometer Alarm Threshold Value)
- (6) Back light On (Off) Function

Each function is as follows:

(1) Work Range Limit Function

NOTICE

If the work range limit is registered too close to an obstacle, the machine can hit the obstacle depending on the crane configuration and operation methods. Consider a sufficient allowance when you register the limit.

The work range limit function restricts the operation of the crane to the pre-registered boom angle (upper limit, lower limit), lifting height, load radius, and swing angle (left, right). Use this function when operating the machine in a place where there are obstacles around the machine or when requiring the working range limit of the boom.

When the crane reaches the registered working range, the limit function works as shown below:

Boom angle upper limit
Boom angle lower limit

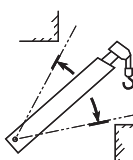

Lifting height limit

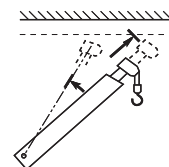

Load radius limit

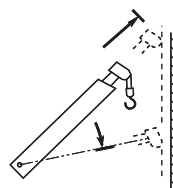

Swing limit

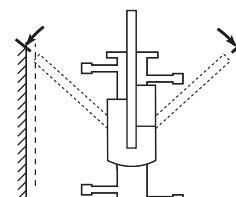

G34021-02E

Work range limit function	Crane state
Boom angle upper limit Boom angle lower limit	• Crane stops automatically.
Lifting height limit Load radius limit	• Load moment indicator built-in buzzer beep-beep-beep
Left swing limit Right swing limit	(Every 1 second for 5 seconds.)

Display of Limit Function State

You can monitor the registered state of the work range limit by the limit indicator lamps on the LED display.

The limit indicator lamp(s) representing the work range limit currently activated lights up.

When the crane reaches the limit and stops automatically, the condition of the limit indicator lamp changes from "staying lit" to "flashing".

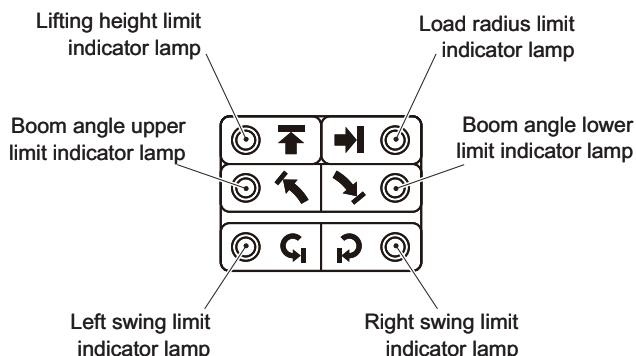

K00695-00E

Registering Boom Angle, Lifting Height, and Load Radius Limit

1. Push the work range limit key to select the item to be registered.

- The pop-up window for work range limit registration appears on the display panel.
- Every time you push the work range limit key, the item to be selected changes in the following sequence.
 1. Lifting height limit
 2. Load radius limit
 3. Boom angle upper limit
 4. Boom angle lower limit
 5. Left swing limit
 6. Right swing limit

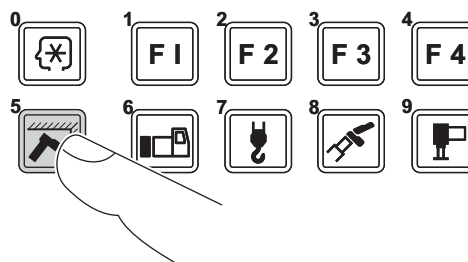

K00696-000

- The illustration on the right shows an example of display where "load radius limit" is registered and "boom angle upper limit" is selected.

☞ Instead of the work range limit key, you can use the F3 (Backward) key or F4 (Forward) key to change the display of the item to be selected.

☞ When you want to stop registration, push the cancel key. The pop-up window closes and the load moment indicator returns to the state before start of the registration.

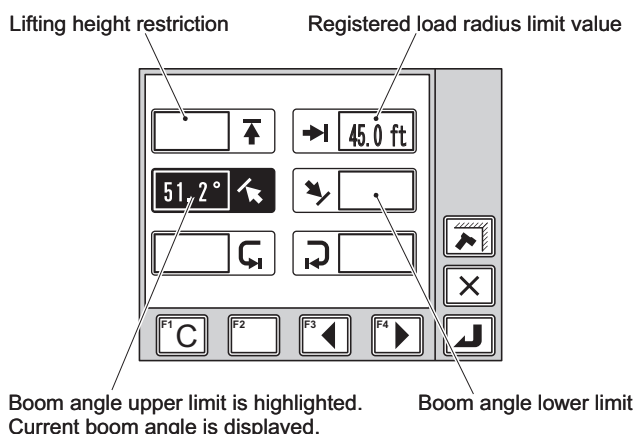

K02568-00E

- 2.** After you operate the boom (jib) to the desired boom angle, height, and load radius, push the set key.
- The corresponding limit indicator lamp flashes in the LED display, and the work range limit is registered.
 - After registration is completed, the pop-up window closes and the load moment indicator returns to the crane operation state.

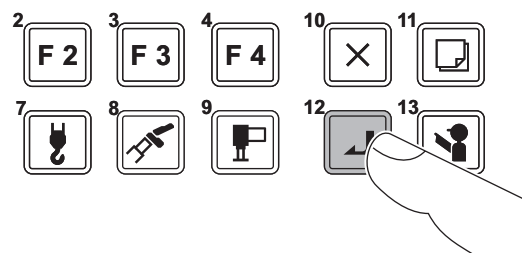

K00678-000

 If you select the item with the limit value already registered, remember that pushing the set key cancels the registration of the work range limit.

- 3.** Move the boom (jib) within the limit range.
- The indicator lamp turns to staying lit.
 - When the state of the crane reaches the registered limit, the indicator lamp flashes. The corresponding operation of the boom (jib) automatically stops, and the error code is shown on the display panel. The load moment indicator built-in buzzer repeats every 1 second for 5 seconds.
- 4.** To cancel the limit function, push the work range limit key to select the item to be canceled.
- The pop-up window for work range limit registration appears on the display panel
- 5.** Push the set key.
- The corresponding limit indicator lamp goes out.
 - The pop-up window closes and the load moment indicator returns to the basic display.

 When you push the F1 (Clear) key, all the work range limits are canceled.

Registration of Swing Range Limit Function

1. Push the work range limit key repeatedly and select the item (left swing limit or right swing limit) to be registered.
 - The symbol for the selected item flashes.
 - Every time you push the work range limit key, the item to be selected changes in the following sequence.
 1. Lifting height limit
 2. Load radius limit
 3. Boom angle upper limit
 4. Boom angle lower limit
 5. Left swing limit
 6. Right swing limit
 - The illustration on the right shows an example of the display where "left swing limit" is selected.

 Instead of the work range limit key, you can use the F3 (Backward) key or F4 (Forward) key to change the display of the item to be selected.

 When you want to stop registration, push the cancel key. The pop-up window closes and the load moment indicator returns to the state before start of the registration.

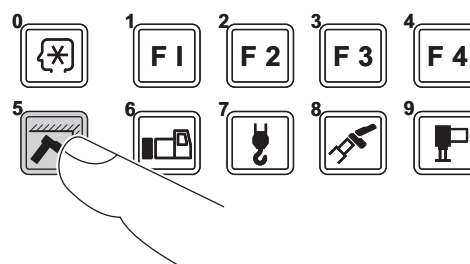

K00696-000

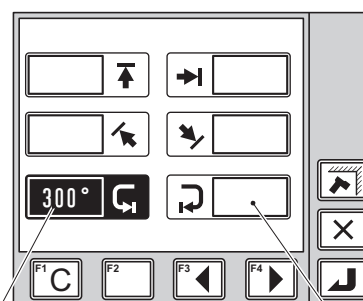

Left swing limit is highlighted.
Current swing angle is displayed.

Right swing limit

K00698-00E

2. After you swing the boom to the desired position where the limit is to be set, push the set key.

- The corresponding limit indicator lamp flashes, and the swing limit is registered.
- After registration is completed, the pop-up window closes and the load moment indicator returns to the crane operation state.

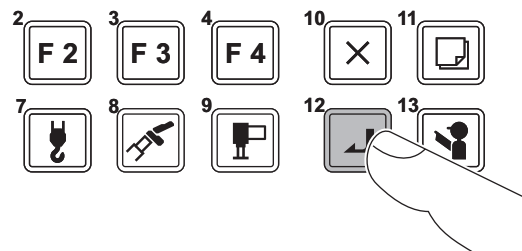

K00678-000

 If you select the item with the limit value already registered, remember that pushing the set key cancels the registration of the work range limit.

- The illustration on the right shows an example of display, in which "swing limit" is registered.

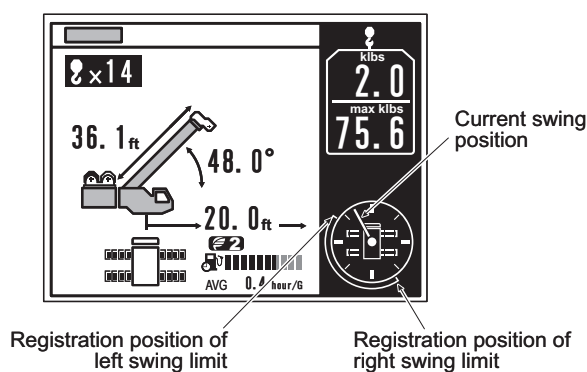

K02996-01E

NOTICE

Registration of swing range limit is the function to set the allowable swing range. Register it for both the left swing and right swing.
If you register the swing range limit only for one side (right or left), the crane does not operate properly.

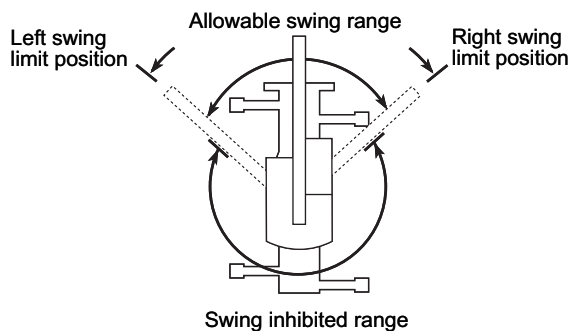

K04519-00E

3. Move the boom (jib) within the limit range.
- The indicator lamp turns to staying lit.
 - When the boom reaches a registered swing limit, the indicator lamp flashes. The swing operation automatically stops, and error code appears on the display panel. The load moment indicator built-in buzzer repeats every 1 second for 5 seconds.

4. To cancel the limit function, push the work range limit key to select the item to be canceled.
 - The pop-up window for work range limit registration appears on the display panel.
5. Push the set key.
 - The corresponding limit indicator lamp goes out.
 - The pop-up window closes and the load moment indicator returns to the crane operation state.

 When you push the F1 (Clear) key, all the work range limits are canceled.

 Even after you turn off the load moment indicator, the registered information is retained for approximately 2 hours.

When the load moment indicator is turned on, the operation starts with the retained information. The registered information is erased approximately 2 hours after the load moment indicator is turned off. In this case, it is necessary to register the operation state from the beginning.

Alarm for Work Range Limit and Recovery Operation

When the crane state reaches the registered limit value, the load moment indicator buzzer sounds, and the error code appears on the display panel. Examine the meaning of the error code, and perform recovery operation.

Error code	Buzzer	Cause	Remedy
[W0026]	Load moment indicator built-in buzzer: beep-beep-beep (Every 1 second for 5 seconds)	The boom angle reaches the upper limit.	Lower the boom.
[W0027]		The boom angle reaches the lower limit.	Raise the boom.
[W0028]		The boom head or jib head reaches the lifting height limit.	Retract or lower the boom.
[W0029]		The load radius reaches the limit.	Retract or raise the boom.
[W0042]		The boom is swung to the swing limit.	Swing the boom in the opposite direction.
[W0043]			

(2) TARE Function

The mass of the load only is shown on the hook load display.

1. Before you lift a load, push the TARE key.
 - The indication of the hook load display turns to "0", and the TARE indicator lamp lights up.

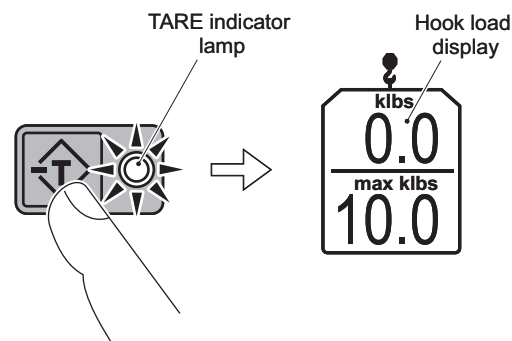

K01258-00E

2. Perform hoist-up operation to lift up the load.
 - The mass of the load is shown on the hook load display.
3. To cancel the TARE function, push the TARE key again.
 - The hook load display returns to the normal hook load display, and the TARE indicator lamp goes out.

(3) Fuel Consumption Indicator

⚠ CAUTION

When you check the fuel consumption indicator, be careful a crane operation is not hindered. Distraction can cause a serious accident.

This function shows the fuel consumption during a crane operation or standby.

Checking the indication enables you to operate a crane in a environmentally friendly way.

The fuel consumption is displayed when the PTO is "ON".

☞ The fuel consumption includes those during on-rubber creep operation.

The following items are shown.

- **Current Fuel Consumption**.....
The current fuel consumption (hour/gallon) during a crane operation is shown as a bargraph.
The max. value in a bargraph is 0.6 hour/gallon.
- **Average Fuel Consumption**.....
The average fuel consumption (hour/gallon) during a crane operation is shown.
The average fuel consumption is reset during standby or when PTO switch is turned to "OFF".
- **Fuel Consumption during Standby**....
The fuel consumption (gallon) during standby is shown.
- **Standby Period**
The crane standby period (min) is shown.

During crane operation

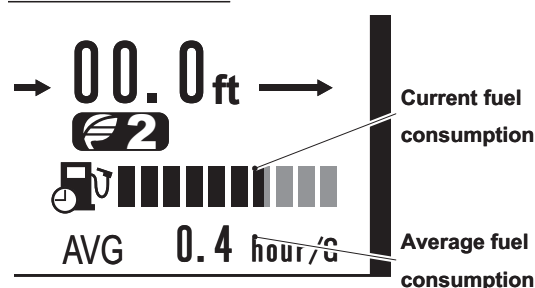

During standby

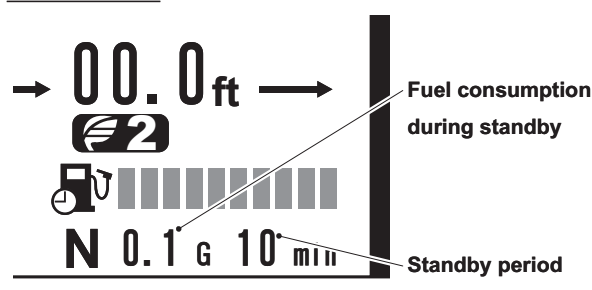

K03066-03E

☞ The crane standby period is the period when each operation lever and pedal are in neutral position.

☞ Fuel Consumption during Standby and Standby Period are displayed when a crane has been in standby mode for a specified period.

☞ The displayed data may be different from the actual data depending on work conditions. Check the fuel gauge to see the remaining fuel amount.

☞ The fuel consumption history during a crane operation and standby is displayed. Refer to "Preset Menu" (page 171).

☞ Refer to "Accessories in Cab" (page 106) to see the fuel consumption ratio at traveling.

(4) Mute Alarm Function

NOTICE

If the mute alarm function is activated, only the error code(s) and warning lamp indicate an error, and the buzzer does not sound. Be sure to deactivate the mute alarm function.

The following alarm buzzers can be muted.

- Alarm buzzer that sounds when the moment load ratio reaches or exceeds 90% (intermittent sound)
- Alarm buzzer that sounds when the moment load ratio reaches or exceeds 100% (continuous sound)

To activate the function, push the mute alarm key while the alarm buzzer sounds.

- The mute alarm warning lamp lights up, and the buzzer stops sounding.

To deactivate the function, push the mute alarm key again.

- The mute alarm warning lamp goes out, and the alarm buzzer sounds.

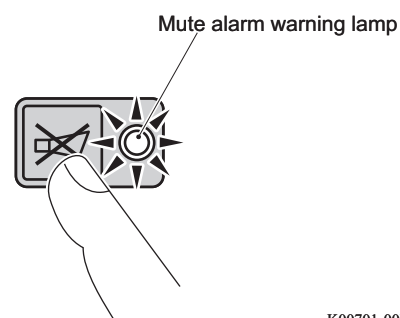

K00701-00E

 In the cases below, the mute alarm function is automatically deactivated.

- The load moment indicator is turned off.
- The alarm buzzer is necessary for other causes.
- The causes to sound buzzer no longer exist.

(5) Preset Menu

CAUTION

**Do not operate the preset menu during a crane operation.
Distraction can cause a serious accident.**

The functions below are available as the preset menu.

- ECO mode selection
- Winch drum rotation buzzer selection
- Fuel consumption history display
- Selection of the winch to be used
- Adjustment of display panel contrast
- Transmission of Telematics data
- Setting of Anemometer Alarm Threshold Value

Preset Menu

1. Push the preset menu key.
 - The pop-up window for the preset menu selection appears on the display panel.

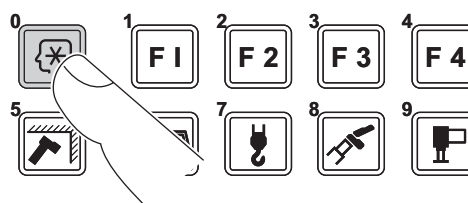

K00702-000

2. Push the F3 (Backward) key or F4 (Forward) key to select the preset icon.
 - The selected preset icon is highlighted.

 Push cancel key to exit the preset menu.
The pop-up window closes, and the crane operation state before the adjustment is restored.

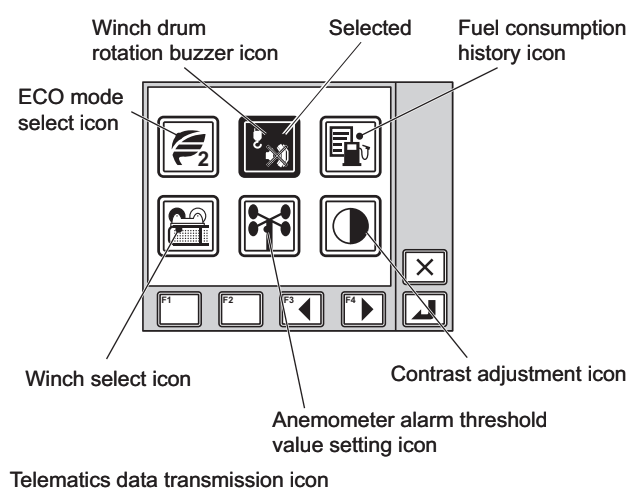

3. Push the set key.
 - The selected preset screen appears.

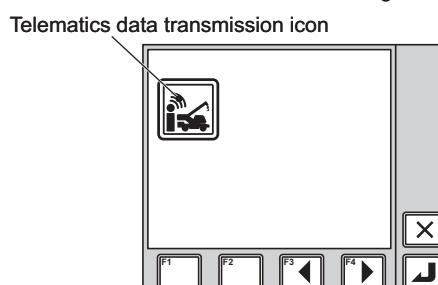

K03071-03E

ECO mode selection

Select a crane operation mode when ECO mode switch is "ON".

- ECO mode 1: In this mode, a crane restricts the maximum engine speed, consumes less fuel and makes less noise compared with when ECO mode is "OFF".
- ECO mode 2: In this mode, a crane consumes further less fuel and makes further less noise compared with when ECO mode 1 is selected.

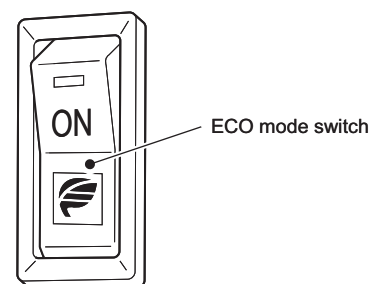

K03532-00E

 A crane operation becomes slower by restricting the maximum engine speed. Select a suitable ECO mode depending on crane operation.

1. Select the ECO mode selection icon, and then push the set key.
 - The pop-up window for ECO mode selection appears on the display panel.
2. Push the F3 (Backward) or F4 (Forward) key to select one of the ECO mode icons.
 - The selected icon is highlighted.

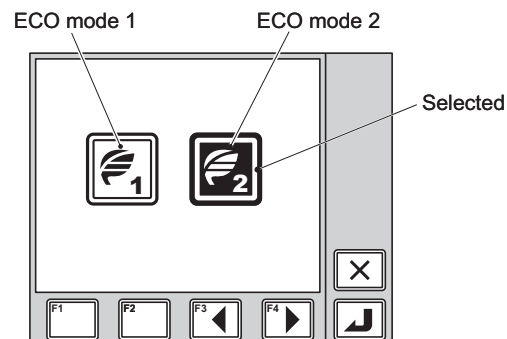

K03072-02E

3. Press the set key.

- After the registration is completed, the pop-up window closes and the load moment indicator returns to the crane operation state.
- When ECO mode switch is turned "ON", ECO mode indicator (ECO mode 1 or ECO mode 2) is displayed.

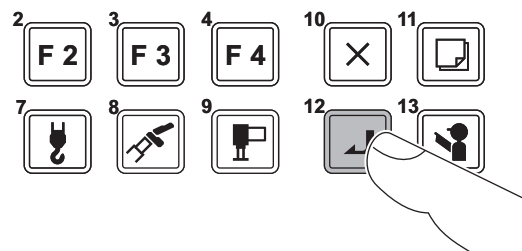

K00678-000

When you want to cancel the selection, push the cancel key.

The pop-up window closes and the load moment indicator returns to the crane operation state without changing registration.

Even after the load moment indicator is turned off, the registered information is retained.

When the load moment indicator is turned on, the operation starts with the retained information.



K03533-02E

Activating/Deactivating the Winch Drum Rotation Buzzer Function

This is the function to sound the buzzer according to the rotation speed of the winch drum. Select whether or not to sound the buzzer.

 The buzzer sounds only while the winch drum turns at a low speed. When the winch drum rotation speed increases, the buzzer stops sounding.

1. Select the winch drum rotation buzzer selection menu icon, and push the set key.
 - The pop-up window for winch drum rotation buzzer selection appears on the display panel.
2. Press the F3 (Backward) or F4 (Forward) key to select one of the rotation buzzer icons.
 - The selected icon is highlighted.

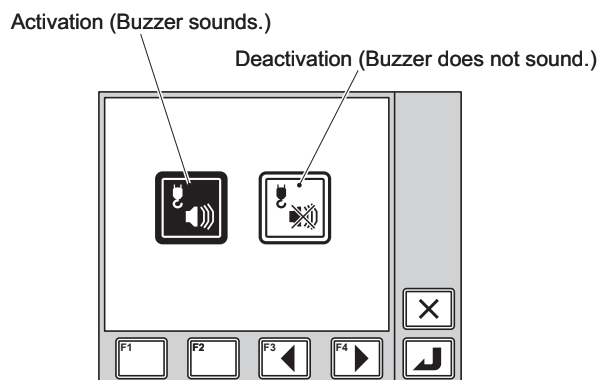

3. Press the set key.
 - After the registration is completed, the pop-up window closes and the load moment indicator returns to the crane operation state.

 When you want to cancel the registration, push the cancel key. The pop-up window closes and the load moment indicator returns to the crane operation state without changing registration.

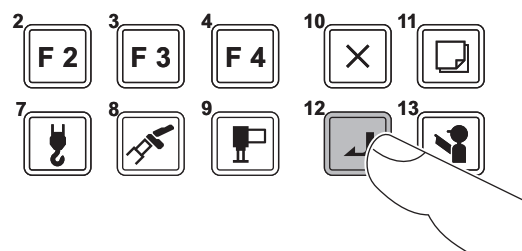

 Even after the load moment indicator is turned off, the registered information is retained. When the load moment indicator is turned on, the operation starts with the retained information.

Fuel Consumption History Display

The fuel consumption history is displayed.

1. Hoist down a load and set each operation lever and pedal to the neutral position.
2. Select the fuel consumption history icon, and then push the set key.
 - The screen for fuel consumption history appears.

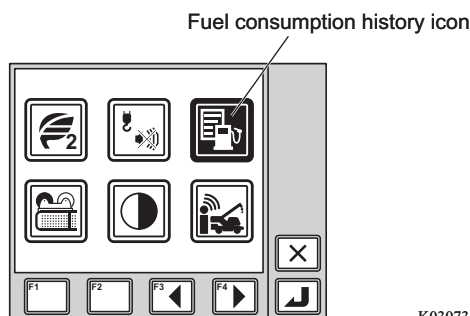

K03073-01E

3. The display changes when the display change key is pushed.
 - The fuel consumption history is shown in either a bargraph or number.
 - The items shown on the numeric display screen are as follows.

G (N) Fuel consumption during standby (gallon)

G (D) Fuel consumption during crane operation (gallon)

h/G Fuel consumption ratio during crane operation (hour/gallon)
 You can change the unit of fuel consumption ratio in h/G (hour/gallon) or G/h (gallon/hour) by pressing F2 (unit change) key.

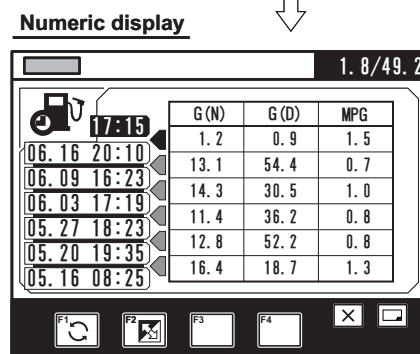
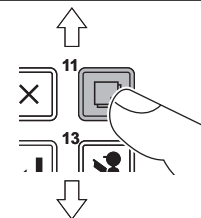
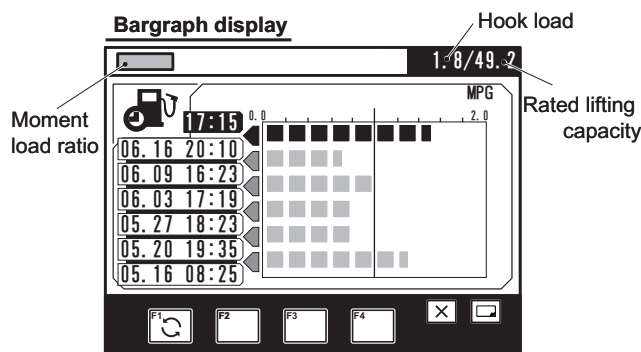

K03074-02E

-  The measurements restart when F1 (reset) key is pushed.
The previous records are moved down by pushing F1 (reset) key. 6 previous records including the current rate are displayed.
You can reset the histories both for traveling and crane operation at the same time by pushing F1 (reset) key and hold it for a while.

-  Press cancel key to exit the history display.
The pop-up window closes and the load moment indicator returns to the crane operation state.

-  G (N) and G (D) includes the fuel consumption during on-rubber creep operation.

Selection of Winch to be used

⚠ WARNING

If the selection of the winch to be used does not agree with the actual state of the crane, the load moment indicator does not indicate the correct value of the load. If you operate the crane in this state, the crane may overturn or be damaged, resulting in an accident. Make sure that the state of actual crane operation and the selection of the winch for use agree before starting operation.

NOTICE

The crane operations other than those shown in the illustrations below are prohibited. Use the specified combinations only.

Select the winch (main winch/auxiliary winch) to be used.

Although the main winch is used in the standard procedure, the auxiliary winch can be selected for single top lift or jib lift. The load lifting capacity differs in accordance with the state of crane operation.

- ☞ When boom lift is registered, only the main winch can be selected.
- ☞ For the rated capacity when the auxiliary winch is selected, follow the description in "Reduction of Rated Lifting Capacity Chart" (page 135).

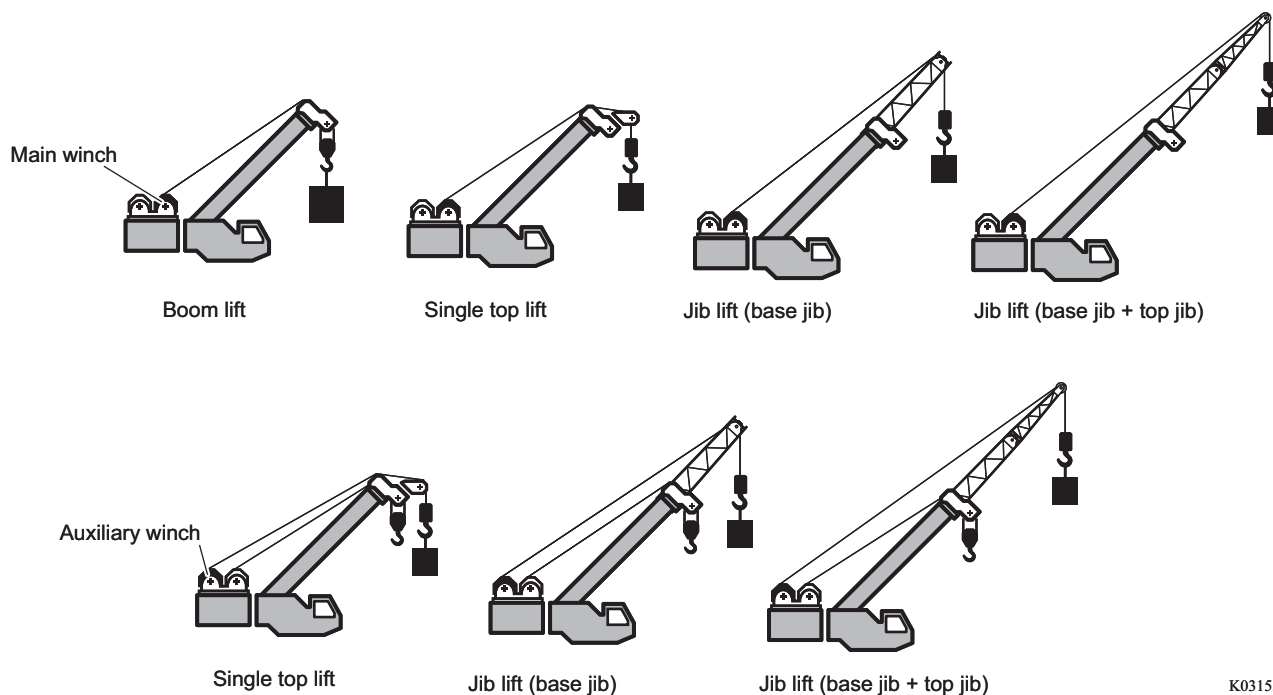

K03155-00E

1. Select the winch select icon, and then press the set key.

- The pop-up window for winch selection appears on the display panel.

2. Press the F3 (Backward) or F4 (Forward) key to select one of the winch icons.

- The selected icon is highlighted.

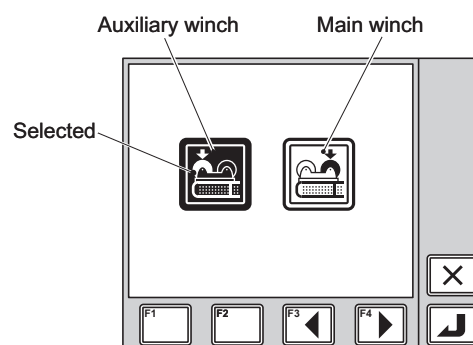

K03158-01E

3. Press the set key.

- When registration is completed, the pop-up window closes and the load moment indicator returns to the crane operation state.

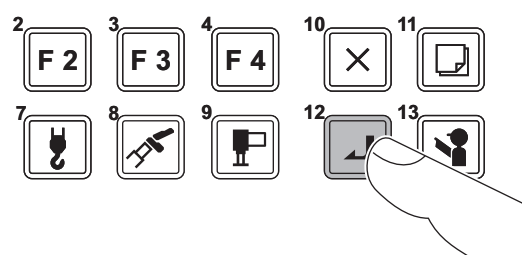

K00678-000

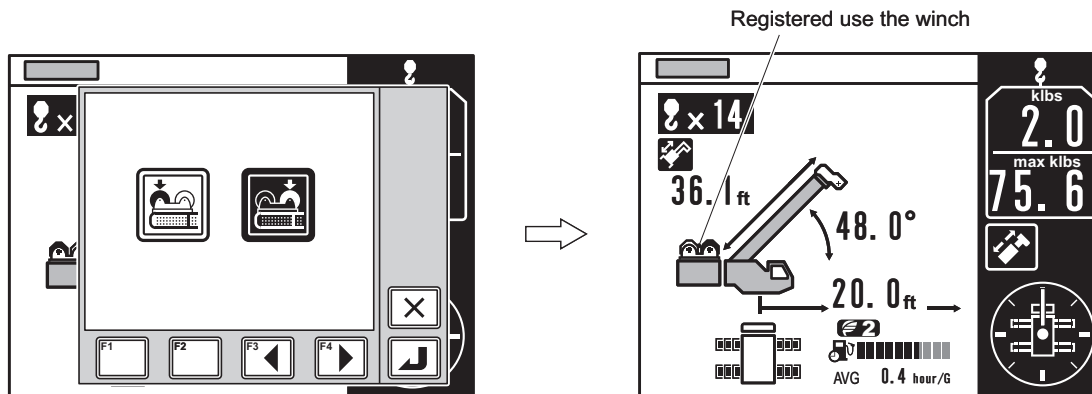

K02997-01E

☞ When you want to cancel the registration, push the cancel key. The pop-up window closes and the load moment indicator returns to the crane operation state without changing registration.

☞ When the load moment indicator is turned off, the registered information is not retained. When the load moment indicator is turned on, the operation starts with "main winch".

Adjustment of Display Panel Contrast

1. Select the contrast adjustment menu icon, and push the set key.
 - The pop-up window for contrast adjustment appears on the display panel.

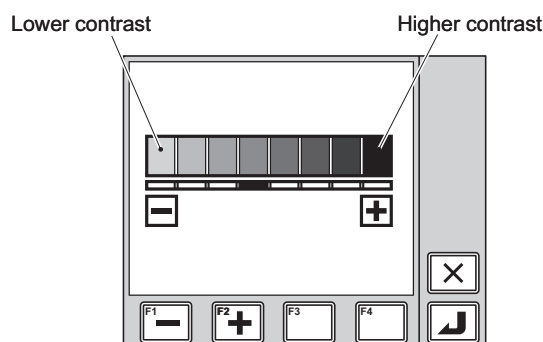

K00711-00E

2. Push the F1 (-) key or F2 (+) key to adjust the contrast.
 - Push the F2 (+) key to increase contrast and the F1 (-) key to decrease contrast.
3. Push the set key.
 - When registration is completed, the pop-up window closes and the load moment indicator returns to the crane operation state.

 When you want to stop registration, push the cancel key. The pop-up window closes and the load moment indicator returns to the crane operation state without changing registration.

 If you push the cancel key for 3 seconds or more, the contrast returns to the initial setting.

 Even after the load moment indicator is turned off, the registered information is retained. When the load moment indicator is turned on, the operation starts with the retained information.

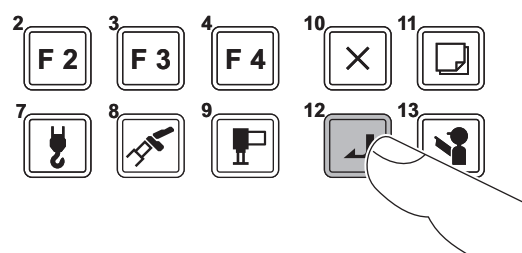

K00678-000

Transmission of Telematics Data

The crane condition can be transmitted to the HELLO-NET server using the communication system mounted on the machine.

If there is any machine trouble etc., use this function by following the instruction from a TADANO distributor or dealer.

1. Select the telematics data transmission menu and press the set key.

- The pop-up window for the telematics data transmission menu appears on the display panel.

 When there is an error in the machine, the details of the alarm (error) are transmitted.

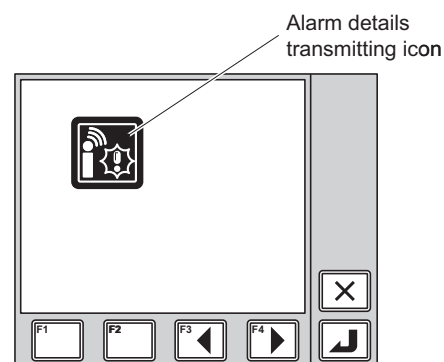

K09717-00E

2. Press the set key.

- After the registration for data transmission is completed, the pop-up window closes, and the load moment indicator returns to the crane operation status.

 There will be a time lag before the data is actually transmitted after the transmission data is registered.

The required time for transmitting varies depending on the communication environment.

 The data cannot be transmitted from inside tunnels or indoors where radio waves are hard to reach. Move to an open-air location, where communication environment is good.

 During transmitting data, the Telematics data icon in the preset menu is faded, and new data transaction cannot be accepted. For transmitting another data, wait until the icon returns to the normal status.

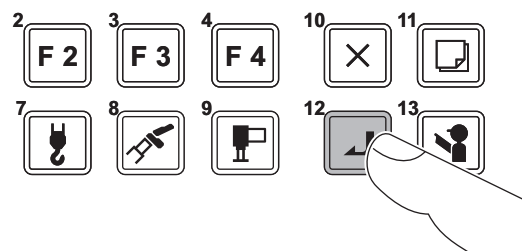

K00678-000

Setting of Anemometer Alarm Threshold Value

While the anemometer (option) is used, if the detected wind speed exceeds the threshold value, an alarm sounds.

Follow the procedure below to register the threshold value.

 When the wind speed measured by the anemometer exceeds the registered threshold value, an alarm sounds, and the error code "W0097" is shown on the load moment indicator.

1. Select the anemometer alarm threshold value setting menu icon, and press the set key.
 - The pop-up window for wind speed alarm threshold value setting is shown on the display panel.

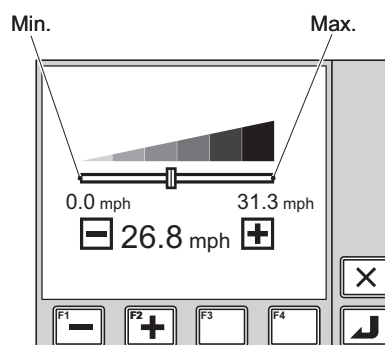

K08782-00E

2. Press the F1 (-) key or F2 (+) key to adjust the threshold value.

Press the F2 (+) key to increase the threshold value and the F1 (-) key to decrease it.

 You can set the threshold value between 0.0 mph (0.0 m/s) and 31.3 mph (14.0 m/s).

3. Press the set key.
 - When registration is completed, the pop-up window closes and the load moment indicator returns to the crane operation state.

 To abort the registration, press the cancel key. The pop-up window closes and the load moment indicator returns to the crane operation status before registration.

 Even after the load moment indicator is turned off, the registered information is retained. When the load moment indicator is turned on, the operation starts with the retained registered information.

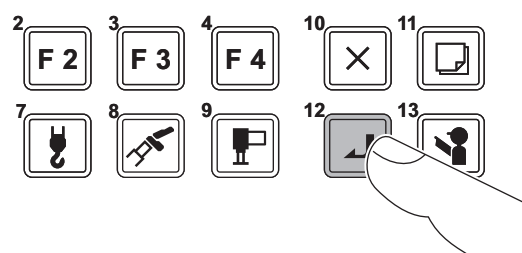

K00678-000

(6) Back light On (Off) Function

You can turn on (or off) the back light for the load moment indicator while the light switch is "OFF".

The load moment indicator back light turns on by pushing and holding the F2 key.

The load moment indicator back light goes out by pushing and holding the F2 key again.

Backlight off status

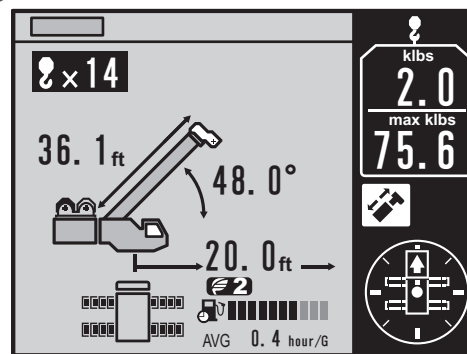

Backlight on status

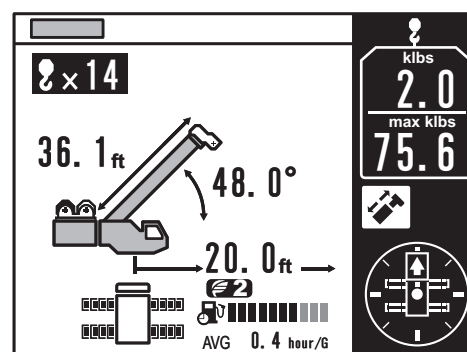

K09767-00E

Action Against Load Moment Indicator System Errors

If the cases listed below occur, an error in the load moment indicator system is the likely cause.

- Even after a recovery operation corresponding to the error code, the error code remains.
- An error code other than given in the error code list is shown.
- The crane stops and you cannot operate it.

In these cases, refer to "If an Error Occurs in the load moment indicator System" (page 432) and stow the crane.

Other Safety Devices

Anti-Twoblock Device

This device prevents the hook block from colliding with the boom, jib, or single top as a result of winch overwinding.

If the hook block touches the weight for the anti-twoblock device (an overwind status), the operation toward the critical side stops.

An alarm (in tremolo) sounds as soon as the crane movement stops. The error code "W0024" is shown on the load moment indicator.

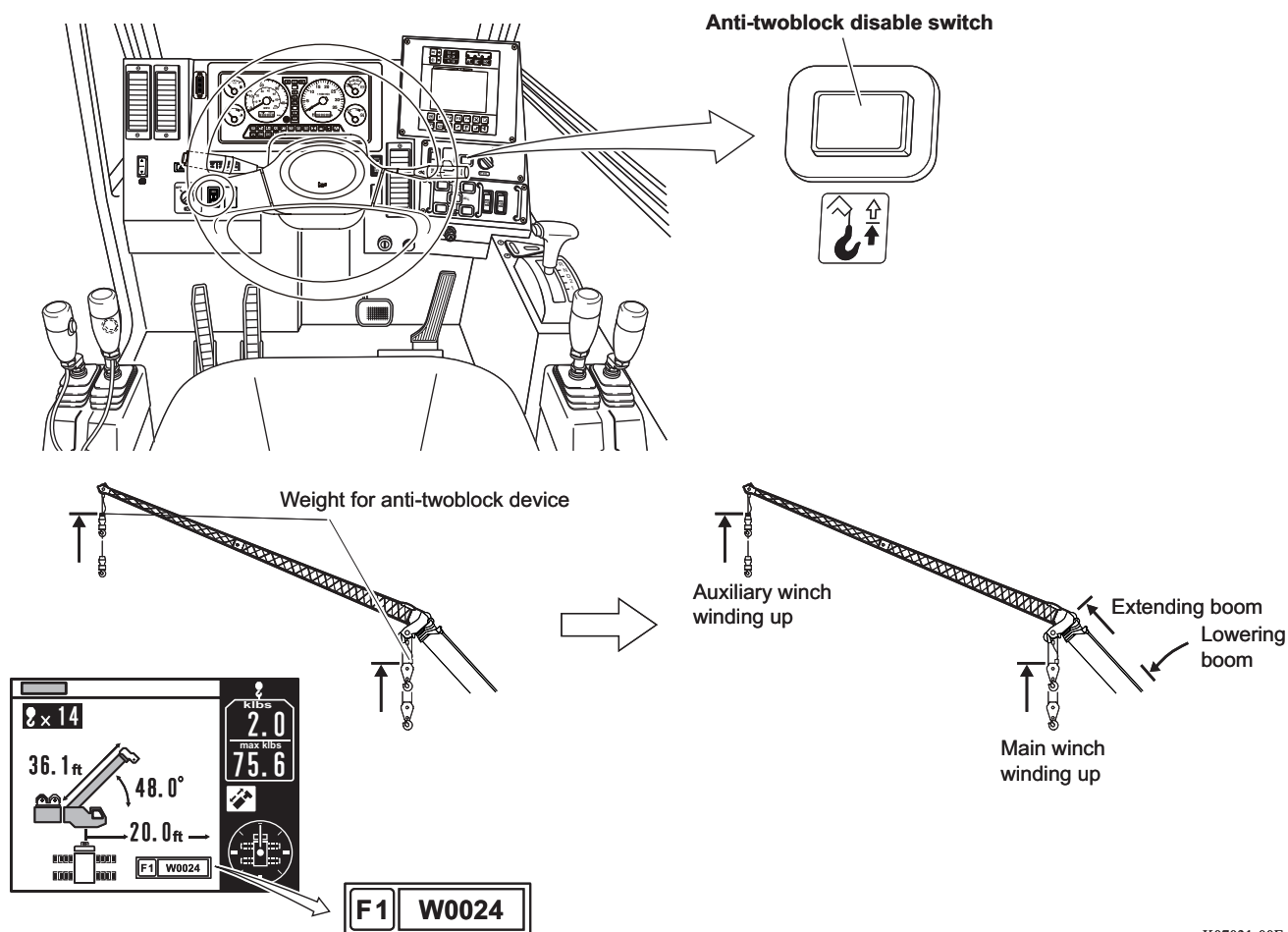

K07031-00E

When the crane reaches the twoblocking status, unwind the winch or retract the boom to move the hook block away from the weight for anti-twoblock device.

When the hook block is moved away from the weight for anti-twoblock device, you can resume the crane operation. The alarm sound (in tremolo) stops and the error code on the load moment indicator disappears.

Canceling Anti-twoblock Function

WARNING

Never operate the crane with the anti-twoblock function canceled. Otherwise, the hook block can collide with the boom, jib, or single top to make a lifted load fall. It can cause a serious accident.

If the anti-twoblock function obstructs operations such as stowing of a hook block, push the anti-two block disable switch.

While you push and hold the switch, the anti-twoblock function is canceled.

 The anti-twoblock function is canceled while a jib set status is registered on the load moment indicator (AML).

Load Moment Indicator External Warning Lamps

These lamps inform the work director and persons around the crane of the present status of the crane.

The lamp of red or yellow lights up according to the status of the crane.

The lighting status of the lamp is linked with the moment load ratio displayed on the load moment indicator (AML).

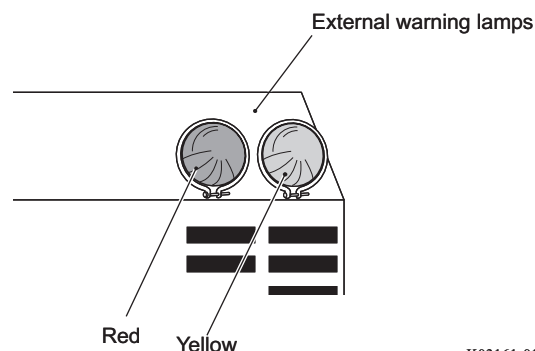

K03161-01E

Lamp status	Cause
Red	Dangerous status (operation toward the critical side automatically stops) <ul style="list-style-type: none"> • Moment load ratio is 100% or more. • The anti-twoblock disable switch is pushed and the anti-twoblock function is disabled. • The override key switch is turned to "ON" and the PTO switch is turned to "OVERRIDE".
Yellow	A status that is not dangerous, but attention is required. <ul style="list-style-type: none"> • Moment load ratio is 90% or more, and less than 100%.
Not lit	Safe status <ul style="list-style-type: none"> • Moment load ratio is less than 90%.

Load Moment Indicator External Warning Lamps (option)

These lamps inform the work director and persons around the crane of the present status of the crane.

The lamp of red, yellow, or green lights up according to the status of the crane.

The lighting status of the lamp is linked with the moment load ratio displayed on the load moment indicator (AML).

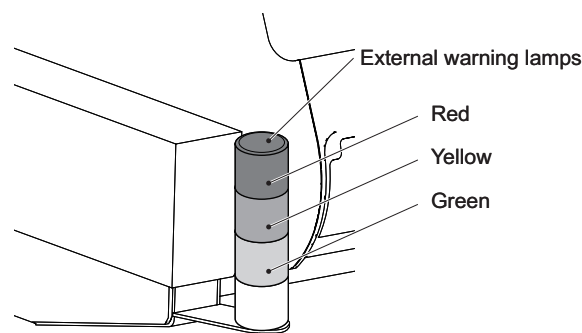

K03517-00E

Lamp status	Cause
Red	Dangerous status (operation toward the critical side automatically stops) <ul style="list-style-type: none"> • Moment load ratio is 100% or more. • The anti-twoblock disable switch is pushed and the anti-twoblock function is disabled. • The override key switch is turned to "ON" and the PTO switch is turned to "OVERRIDE".
Yellow	A status that is not dangerous, but attention is required. <ul style="list-style-type: none"> • Moment load ratio is 90% or more, and less than 100%.
Green	Safe status <ul style="list-style-type: none"> • Moment load ratio is less than 90%.

Anemometer (Option) (For Serial No. 548535 or later)

⚠ WARNING

A strong wind sways the lifted load. This is dangerous to workers and surrounding structures, and can damage the boom and overturn the machine. Note that the longer the boom is, and the larger the area of the load is, the more the wind affects the machine. The rated lifting capacity does not include the effect of the wind on the load, boom or jib. If you find it difficult to control the load because of the wind, stop crane operation. During boom lift, when the wind speed is between 20 mph (9 m/s) and 27 mph (12 m/s), reduce the rated lifting capacity by 50%, and when the wind speed is between 27 mph (12 m/s) and 31 mph (14 m/s), reduce it by 70%. Stop operation when the wind speed exceeds 31 mph (14 m/s). During jib lift, stop operation when the wind speed exceeds 20 mph (9 m/s).

NOTICE

If the display of the wind speed on the load moment indicator is not correct, check the connections of the electric cables.

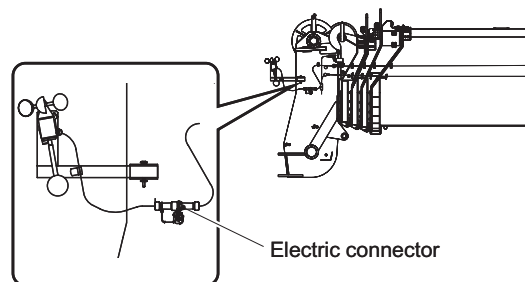

K09697-00E

The anemometer measures the wind speed at the boom or jib head in order to prevent damages to the crane or an overturning accident caused by a strong wind.

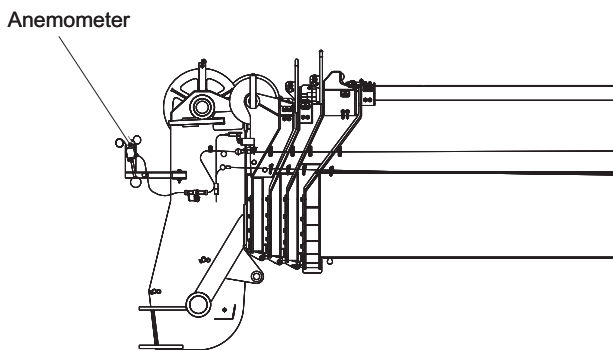

Load moment indicator

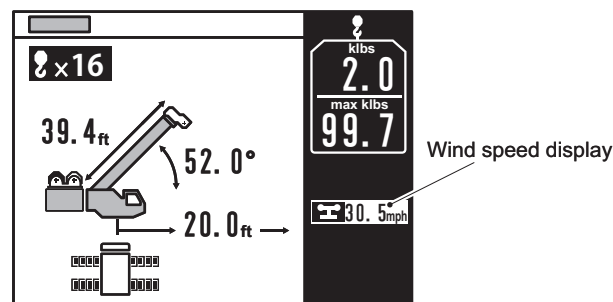

K09698-00E

☞ To display the wind speed, press the display change key on the load moment indicator. Refer to the "Selecting the Display" (page 144).

☞ The anemometer threshold value for alarm can be set according to the situation. Refer to the "Setting of Anemometer Alarm Threshold Value" (page 181).

☞ When the wind speed measured by the anemometer exceeds the registered threshold value, an alarm sounds, and the error code "W0097" is shown on the load moment indicator.

Installing Anemometer

Mounting on boom

1. Turn the starter switch to "OFF".
2. Install the anemometer to the mounting support on the head of the boom and fix with the fixing pin.

⚠ WARNING

To prevent the anemometer from falling, make sure that the fixing pins are mounted securely.

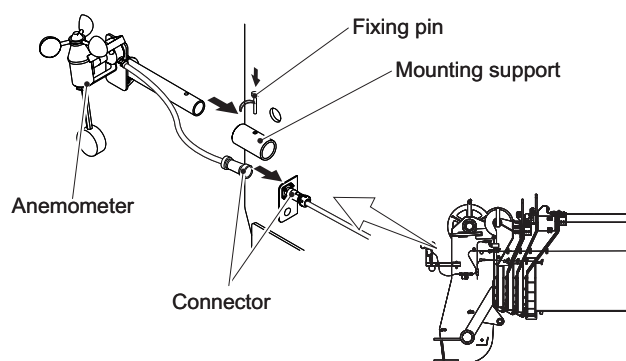

3. Connect the electric cable.

⚠ WARNING

After the connectors are connected, fix the removed caps of the connectors to the stowing support. If the caps are not fixed to the support securely, they can fall, resulting in an accident.

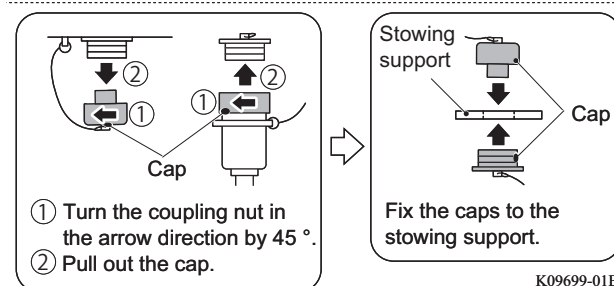

K09699-01E

Mounting on jib

1. Turn the starter switch to "OFF".
2. Install the anemometer to the mounting support on the head of the jib and fix it with the fixing pin.

⚠ WARNING
To prevent the anemometer from falling, make sure that the fixing pins are mounted securely.

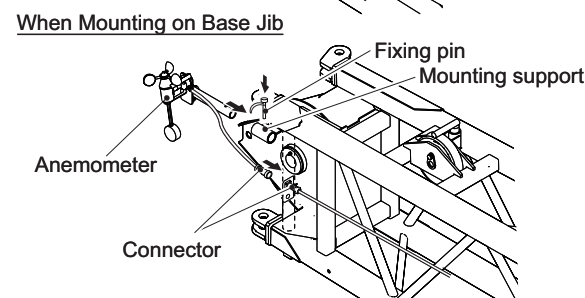
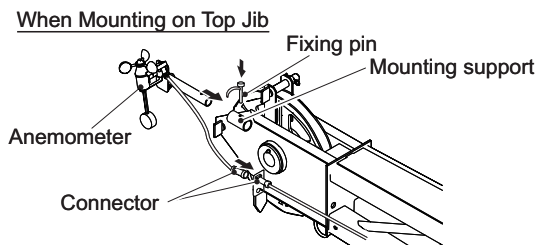

3. Connect the electric cables at the jib head and boom head.

⚠ WARNING
After the connectors are connected, fix the removed caps of the connectors to the stowing support. If the caps are not fixed to the support securely, they can fall, resulting in an accident.

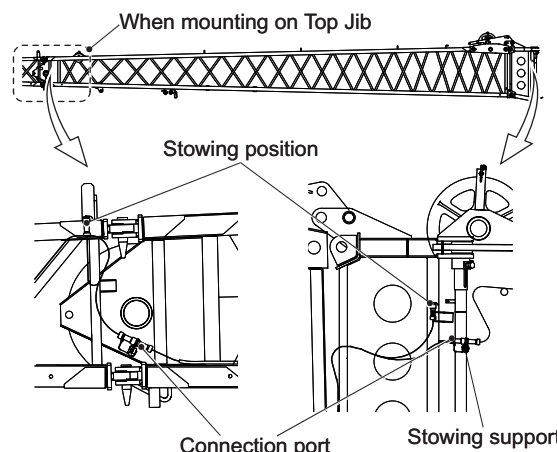

☞ When mounting on the top jib, connect the electric cables between the top jib and base jib as well.

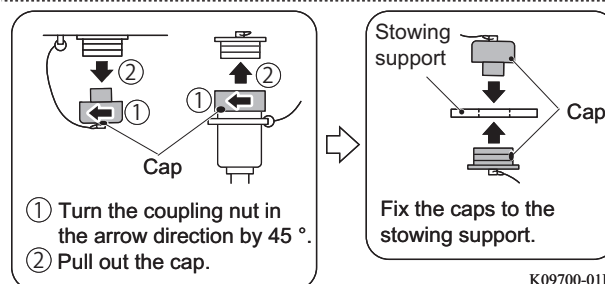

K09700-01E

Removing Anemometer

NOTICE
Do not travel with the anemometer being mounted. The anemometer can be broken. Remove the anemometer before traveling or machine being transported.

Remove the anemometer following the installing procedure in reverse.
 After the anemometer is removed, attach caps on the removed electric connectors.

PTO

When you operate the outrigger and crane, turn the PTO switch to "ON".

When you drive on a road, turn the PTO switch to "OFF".

PTO "ON" Operation

1. Run the engine at idle.
2. Make sure that the control devices are in the conditions as shown in the illustration.

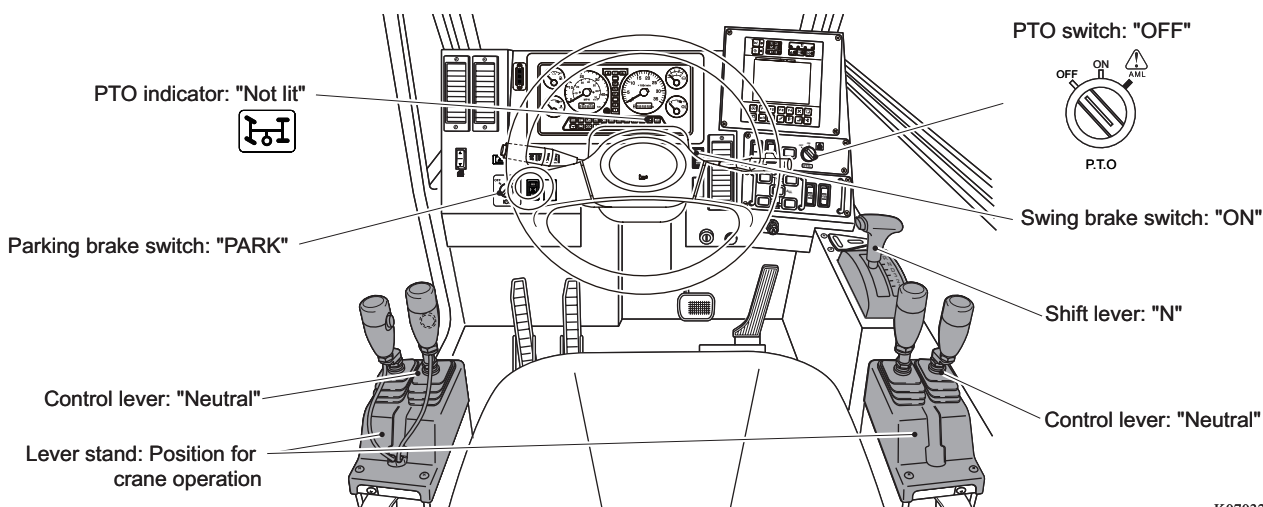

K07032-00E

☞ For adjustment of the control lever stands, refer to the "Adjustment of the Control Lever Stand" (page 72).

3. Turn the PTO switch to "ON".
 - The PTO indicator lights up.
 - The hydraulic pump is driven.
 - Power of the load moment indicator is turned on.
 - The suspension lock is completed, and the suspension lock indicator lights up.

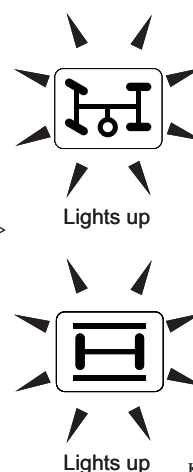
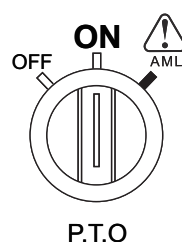

K02998-00E

NOTICE

To prevent failure of the PTO, run the engine at idle before you turn the PTO switch to "ON".

☞ In cold season, warm up the machine according to the ambient temperature.

PTO "OFF" Operation

1. Run the engine at idle.
2. Turn the PTO switch to "OFF".
 - The PTO indicator goes out.
 - The hydraulic pump stops.
 - Power of the load moment indicator is turned off.
 - The suspension lock is released, and the suspension lock indicator goes out.

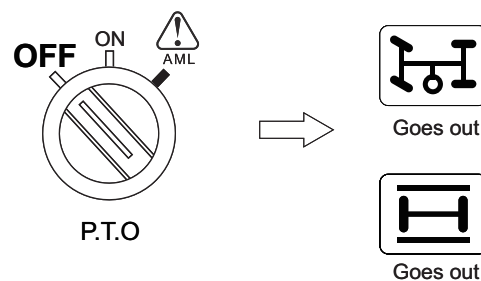

K02999-00E

Outriggers

Inside the Cab

(1) Outrigger switch out-of-neutral icon

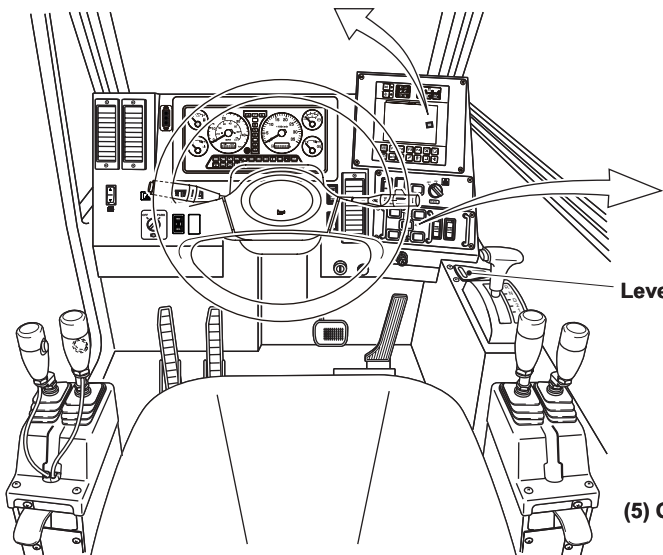

(6) Outrigger control switch (left front)

(8) Outrigger control switch (right front)

(2) Extend/retract selector switch

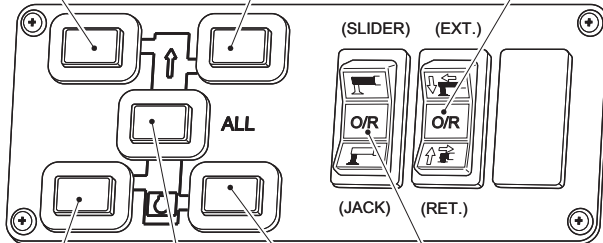

Level

(4) Central control switch

(3) Jack/slide selector switch

(5) Outrigger control switch (left rear)

(7) Outrigger control switch (right rear)

K07033-00E

(1) Outrigger Switch Out-of-neutral Icon

Flashes when an extend/retract selector switch or jack/slide selector switch is out of the neutral position. It reminds you to return the switch (es).

(2) Extend/Retract Selector Switch

Select "EXT." to perform an extending operation, and select "RET." to perform a retracting operation.

(3) Jack/Slide Selector Switch

Select "JACK" to operate the jack(s), and select "SLIDER" to operate the beam (s).

(4) Central Control Switch

Push this switch to operate all beams or jacks simultaneously.

(5) Outrigger Control Switch (Left Rear)

Push this switch to operate the rear left beam or jack.

(6) Outrigger Control Switch (Left Front)

Push this switch to operate the front left beam or jack.

(7) Outrigger Control Switch (Right Rear)

Push this switch to operate the rear right beam or jack.

(8) Outrigger Control Switch (Right Front)

Push this switch to operate the front right beam or jack.

 The alarm buzzer in the cab sounds if an outrigger is not operated approx for 10 seconds or more while the extend/retract selector switch or jack/slide selector switch is not in neutral (the "outrigger switch out of neutral icon" flashes on the load moment indicator).

Extension Width of Outriggers and Appearance Marks on the Side of Outrigger Beams

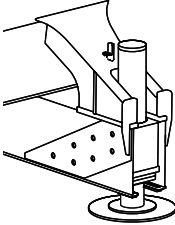
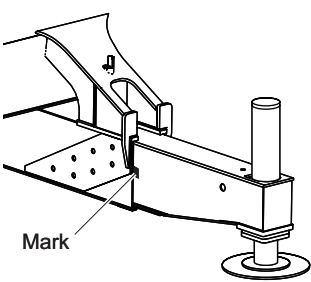
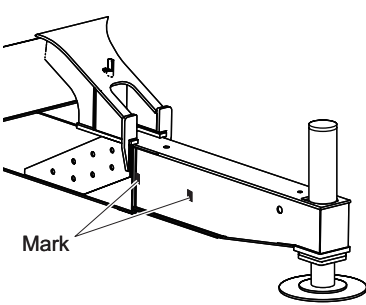
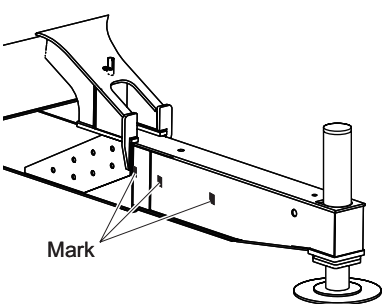
Extension width of outriggers	Marks on outrigger
Minimum extension	
Middle extension 1	
Middle extension 2	
Maximum extension	

K03150-01E

Outrigger Set-up

⚠ WARNING

- If the outrigger is set up on unsuitable ground, the ground can collapse and cause the machine to overturn. Set up the machine on a firm and level ground.
- On an inclined ground, make sure that stoppers are set to the tires before operating the outriggers. If the machine moves, it can result in an accident.
- If the machine is not set up horizontally, the load radius increases when the boom is swung to the lower side of inclination. This can cause the machine to overturn. When you set up the outriggers, use the bubble level to make sure that the machine is set up horizontally.
- If any tire is in contact with the ground when the outriggers are set up, the stability of the machine is reduced due to the reaction force of the tires, and it can cause the machine to overturn. If you cannot make the tires come off the ground, set the pads under the outriggers to make sure that all tires are off the ground.
- When the outrigger extension width is small, the stability of the machine decreases, and it can cause the machine to overturn. As a rule, extend the outrigger beams to the maximum.

It is essential to set up the outriggers on a firm and level ground which can support the weight of the lifted load and machine body to operate the crane safely.

On a soft, inclined, or rough ground, make sure that the ground is treated with the procedures below and has sufficient strength before you set up the outriggers.

- The ground is leveled so that the machine can be set up horizontally.
- The pads (standard equipment) with sufficient coverage and strength that suit ground conditions are set under the outrigger float.

In some cases, the ground that seems to be rigid enough cannot support the machine, depending on the internal condition of the ground. Be careful when you set up the machine on the ground listed below.

- Road surfaces paved with blacktop
- Stone-paved road surfaces such as a sidewalk
- Backfilled site after excavating work
- Reclaimed land
- Shoulder of a road or periphery of an excavated hole

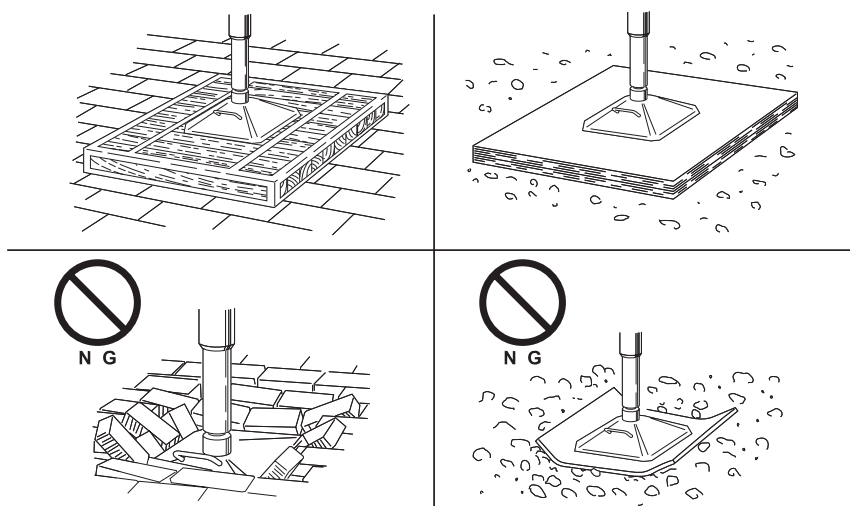

G37004-00E

Extending the Outriggers

⚠ WARNING

Before operation, check that no one is around the outriggers or under the machine. Otherwise, a person can be hit by the outrigger or crushed by the machine.

Adjust the operating speed with the accelerator pedal.

1. Make sure that the shift lever is set to "N", and the parking brake switch is set to "PARK".

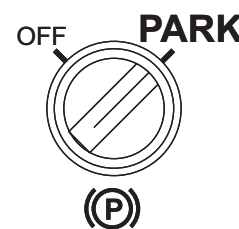
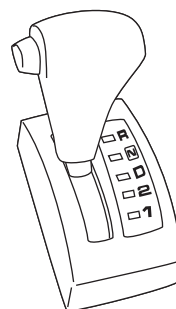

K02925-000

2. If the machine is parked on an inclined ground, apply stoppers to the downward side of each wheel before you operate the outriggers from outside of the cab. Place the stopper against each wheel.

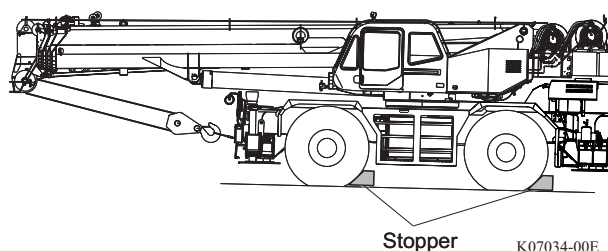

K07034-00E

3. Pull out all four lock pins.

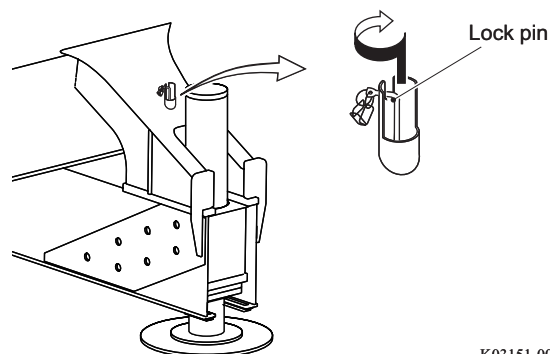

K03151-00E

4. Set the jack/slide selector switch to "SLIDER", and set the extend/retract selector switch to "EXT".

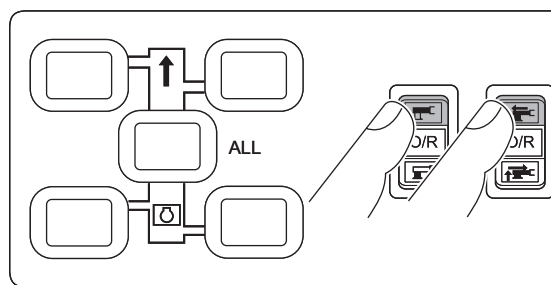

K01595-000

5. When extending the outriggers to maximum extension:

Push the central control switch to extend all outrigger beams completely.

When extending the outriggers to middle or minimum extension:

Push the central control switch or the individual outrigger control switch to extend the outrigger beams.

Refer to "Extension Width of Outriggers and Appearance of Marks on the Side of the Outrigger Beam" (page 194).

 For minimum extension, extend the jacks only, without extending the outrigger beams.

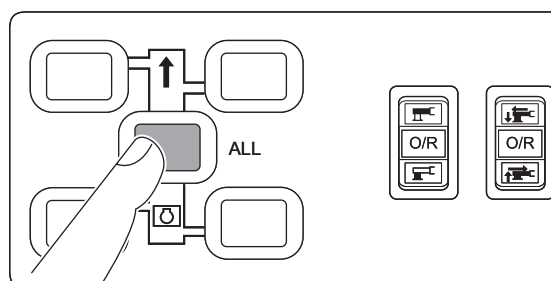

K01596-000

6. Insert all the four lock pins into the pin-holes to lock the outrigger beams.

WARNING

Make sure that all the lock pins are inserted before you operate the crane. Otherwise, the outrigger beams can retract during operation, causing an overturning accident. After extending the outrigger beams, be sure to insert the lock pins.

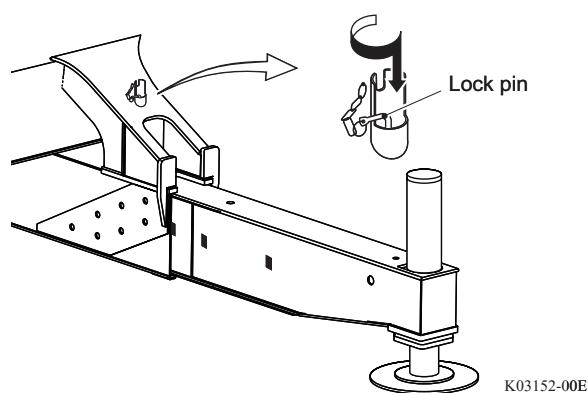

K03152-00E

7. Set the jack/slide selector switch to "JACK" and set the extend/retract selector switch to "EXT".

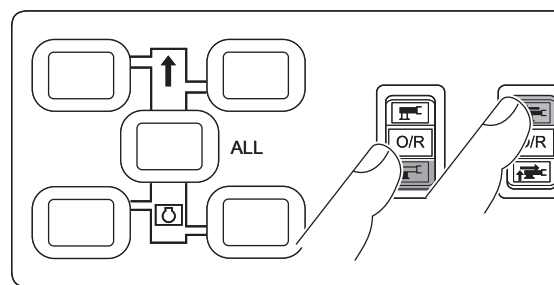

K01597-000

8. Push the central control switch to extend all the jack cylinders completely.

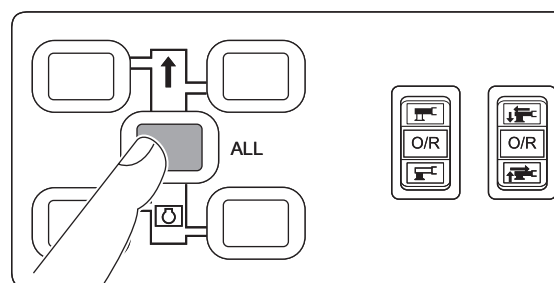

K01596-000

9. Check that the machine is set up horizontally using the bubble level. If it is not set up horizontally, refer to "Horizontal Set-up" (page 201) to set the machine up horizontally.
- When the bubble in the level is between the marking lines, the machine is horizontal.

⚠ WARNING

Sometimes, the machine can be supported horizontally only by 3 jack cylinders. If you operate the crane in this state, an overturning accident can occur. Check that all the outrigger floats are firmly in contact with the ground. If any of the floats are off the ground, adjust them into proper seating on the ground.

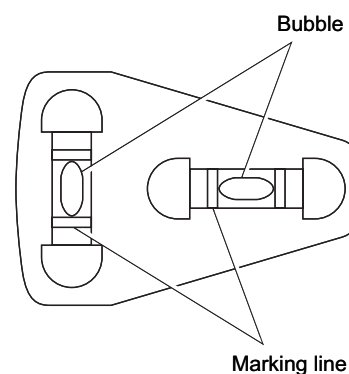

G37011-01E

- 10.** Return the jack/slide selector switch and the extend/retract selector switch to the neutral positions.
- Check that the indicator of the outrigger switch out of neutral icon on the load moment indicator is not lit.

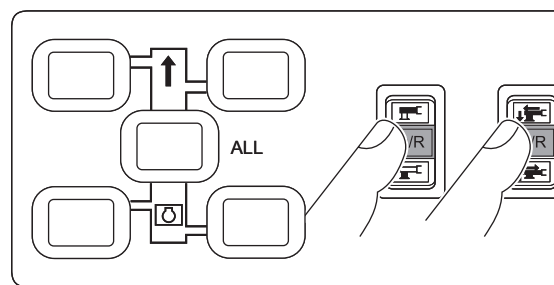

K01598-000

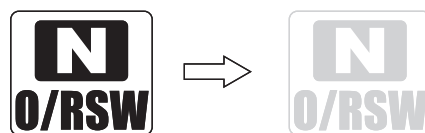

Goes out

K00538-00E

Horizontal Set-up

How to Read the Bubble Level

The horizontal set-up is attained when the machine is set-up with the bubbles in the bubble levels coming in between the marking lines.

Check the horizontal set-up of the machine while the boom is directed toward the front.

- Example: Left side of the vehicle is higher -

The bubble in the level moves to the left.

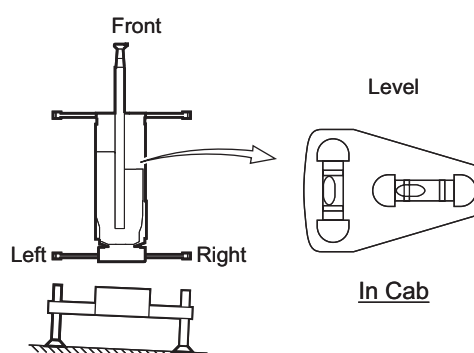

K01751-00E

Operation

Retract the jacks on the higher side to set the machine horizontally. The following describes an example in which the left side of the machine is higher.

1. Set the jack/slide selector switch to "JACK" and set the extend/retract selector switch to "RET".

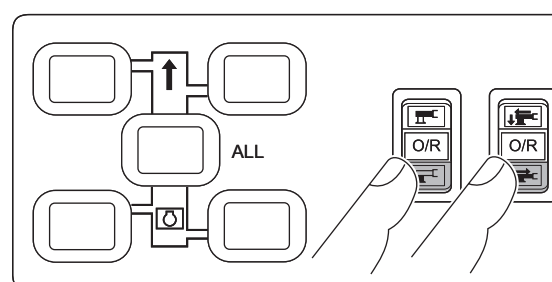

K01599-000

2. While checking the bubbles in the level, push the "LEFT FRONT" and "LEFT REAR" outrigger control switches repeatedly to retract the left jack cylinders and set the machine horizontally.
 - When the bubbles in the level are between the marking lines, the machine is set up horizontally.

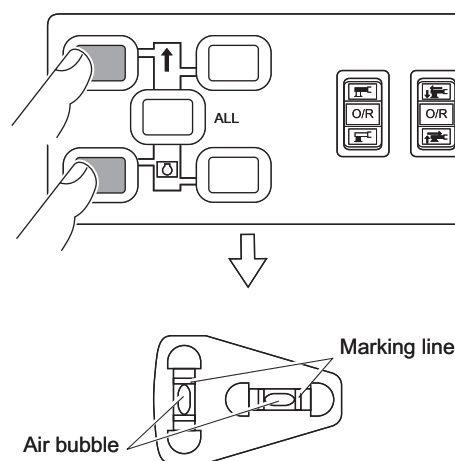

K01600-00E

3. Return the jack/slide selector switch and the extend/retract selector switch to the neutral positions.

Stowing the Outriggers

⚠ DANGER

If the outriggers are stowed while the boom is extended or raised, the machine overturns. Before stowing the outriggers, retract the boom fully, and set the machine into the traveling configuration.

⚠ WARNING

Before operation, check that no one is around the outriggers or under the machine. Otherwise, a person can be hit by the outrigger or crushed by the machine.

Adjust the operating speed with the accelerator pedal.

1. Set the machine into the traveling configuration, and check that the parking brake switch is set to "PARK".

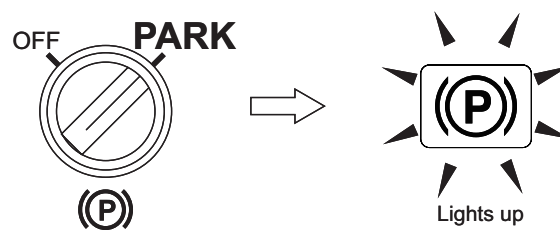

K01229-00E

2. Set the jack/slide selector switch to "JACK" and set the extend/retract selector switch to "RET".

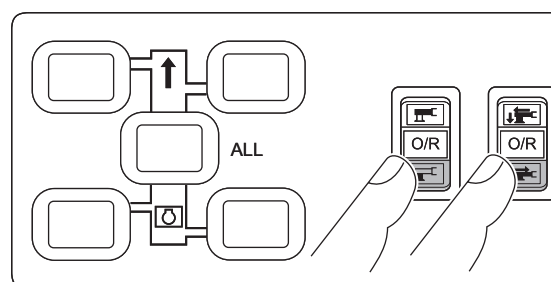

K01599-000

3. Push the central control switch to retract all jacks fully.

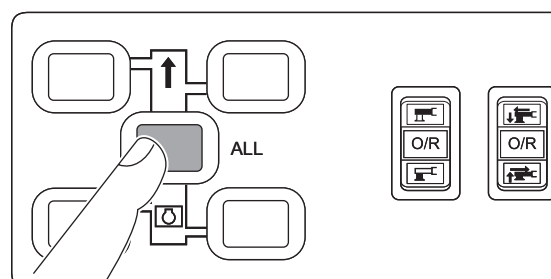

K01596-000

4. Remove all four lock pins.

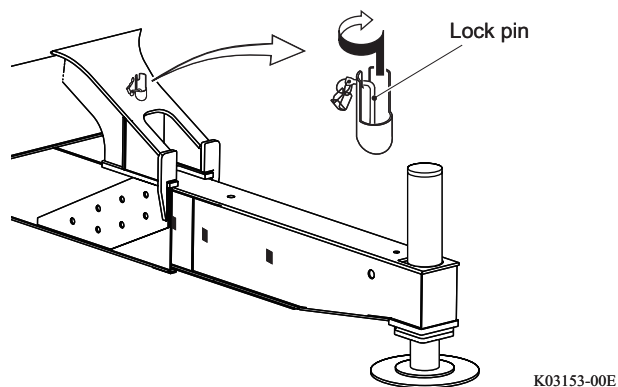

5. Set the jack/slide selector switch to "SLIDER" and set the extend/retract selector switch to "RET".

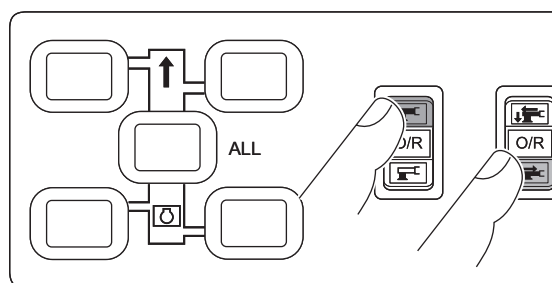

6. Push the central control switch to retract all outrigger beams fully.

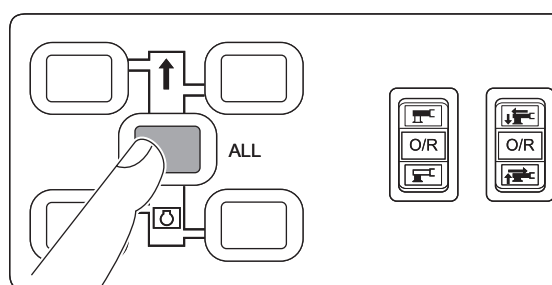

7. Return the jack/slide selector switch and the extend/retract selector switch to the neutral positions.
- Check that the outrigger switch out-of-neutral icon on the load moment indicator has gone out.

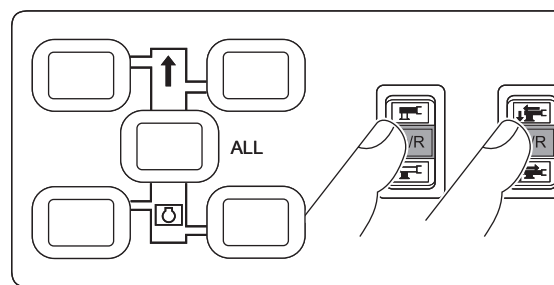

K01598-000

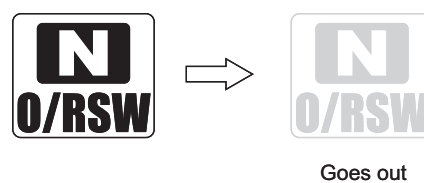

K00538-00E

8. Insert all four lock pins into the pinholes to lock the outrigger beams.

⚠ WARNING

Do not travel without the lock pins being inserted. Otherwise, the outrigger beam can extend and hit passersby or passing vehicles during traveling. After you stow the outrigger beams, always insert the lock pins.

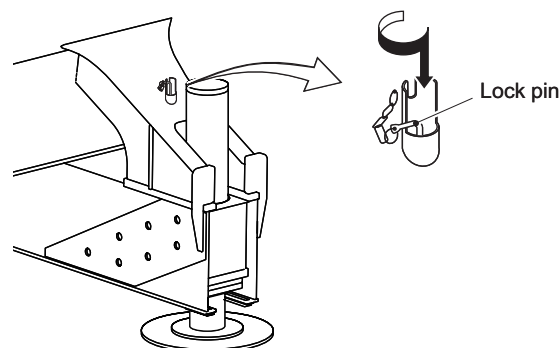

K03154-00E

Hoisting

Boom telescoping/auxiliary hoist control selector switch

Selects the control mode (telescoping or auxiliary hoist) for the boom telescoping/auxiliary hoist control lever.

Boom telescoping/auxiliary hoist control lever

Drum indicator

Auxiliary hoist control icon

Displayed when the boom telescoping/auxiliary hoist control selector switch is set to "auxiliary winch".

Main hoist control lever

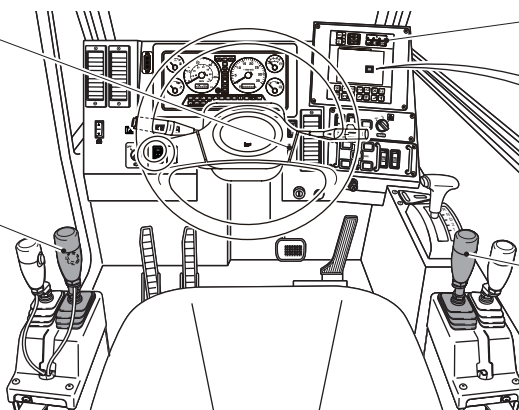

K07035-00E

Hoisting Up/Down

⚠ WARNING

Never drag a load sideways, or pull-in the load by hoisting operation. Otherwise, the machine can be damaged and an overturning accident can occur.

NOTICE

When the load is lifted just clear of ground, the load radius can increase due to the deflection of the boom, and this can cause an overloading. In this case, decrease the load, or move the machine to a place where the load radius can be decreased.

Hoisting up/down operation is performed by operating the winch lever.

Winch speed is adjusted by operating amount of the winch lever and accelerator operation.

Main Winch

Operate the main hoist control lever to hoist up/down a load.

- Hoisting down Push the lever forward.
- Stop Return the lever to the neutral position.
- Hoisting up Pull the lever backward.

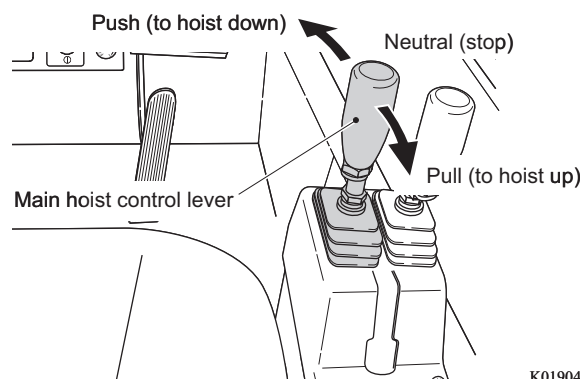

K01904-00E

⚠ WARNING

Abrupt lever operation can cause the load to bounce or sway, resulting in an accident causing injury or death, or machine damage. Operate the lever slowly.

Auxiliary Winch

⚠ WARNING

Before you operate the auxiliary winch, check that the auxiliary hoist control mode is selected.

If you attempt to operate the winch while the boom telescoping control mode is selected, an accident can occur.

1. Push the "auxiliary winch" side of the boom telescoping/auxiliary hoist control selector switch.
 - The auxiliary hoist control icon is highlighted.

 Push down and hold the lock knob, and push the "auxiliary winch" switch.

Boom telescoping/auxiliary hoist control selector switch

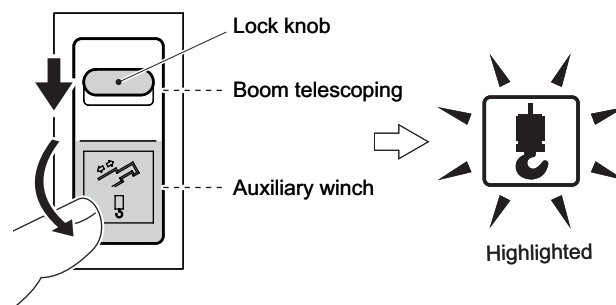

K01905-00E

2. Operate the boom telescoping/auxiliary hoist control lever to hoist up/down a load.
 - Hoisting down ... Push the lever forward.
 - Stop Return the lever to the neutral position.
 - Hoisting up Pull the lever backward.

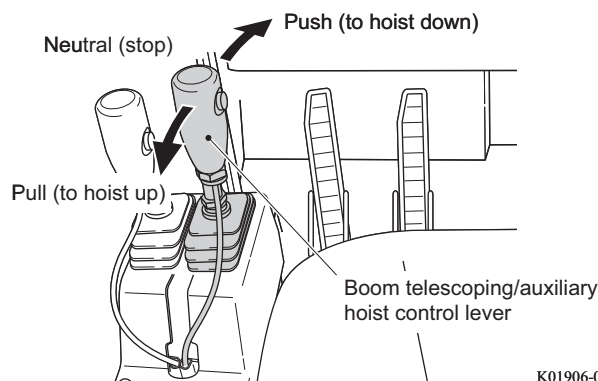

K01906-00E

⚠ WARNING

Abrupt lever operation can cause the load to bounce or sway, resulting in an accident causing injury or death, or machine damage. Operate the lever slowly.

Drum Indicator (Visual Type)

When the winch drum rotates, the four drum indicators flash sequentially, and show that the drum is rotating.

The moving distance of the hook block per one flash of the indicator is approximately 0.8 in. to 1.2 in. (20 mm to 30 mm).

The winch to be indicated is as shown below, according to the winch selection on the load moment indicator winch selection menu, or the lift status registered to the load moment indicator.

- Main winch is selected Main winch
- Auxiliary winch is selected,
 Boom lift is registered Main winch
 Single top/jib lift is registered Auxiliary winch

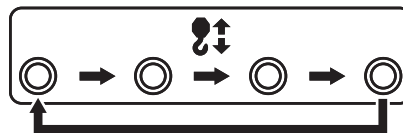

K00542-000

Drum Indicator (Vibration Type) (Option)

When the winch drum rotates, the pulsating section of the winch lever vibrates.

 The winch lever vibrates only when the winch drum turns at a low speed.

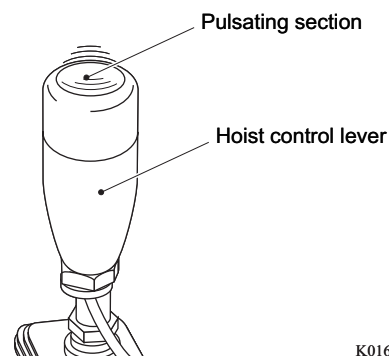

K01662-00E

Boom Telescoping Control

Boom telescoping/auxiliary hoist control selector switch

Selects the control mode (telescoping or auxiliary hoist) for the boom telescoping /auxiliary hoist control lever.

Boom telescoping/auxiliary hoist control lever

Head/end boom extension switch

In the boom telescoping mode I, the switch is used to extend the 3rd/4th/top boom sections by pressing it after the 2nd boom section is fully extended.

In the boom telescoping mode II, the switch is used to extend the 2nd boom section by pressing it after the 3rd/4th/top boom sections are fully extended.

Boom telescoping control pedal



Boom telescoping icon
Displayed when the boom telescoping/auxiliary hoist control selector switch is set to "boom telescoping".

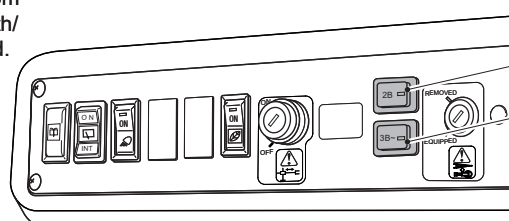

2nd boom emergency telescoping switch

3rd/4th/top boom emergency telescoping switch

K07036-01E

Boom Telescoping Control

⚠ WARNING



- Abrupt lever operation can cause the load to bounce or sway, resulting in an accident causing injury or death, or machine damage. Operate the levers and pedals slowly.
- Do not push or pull in a load by telescoping operation. The machine can be damaged, resulting in an accident.

- ☞ The boom may not be telescoped depending on the weight of the load, boom angle, and lubrication between the boom sections.
- ☞ If the boom is left extended for a long time, the extended boom telescope cylinder may retract gradually due to a temperature change of the hydraulic oil. This is caused by the reduced volume of the hydraulic oil, and not a malfunction. The retracting amount varies depending on the state of the boom telescoping, boom angle, and lubrication between the boom sections.

The boom is a 5-section telescoping type. The boom telescoping is controlled by operating the boom telescoping/auxiliary hoist control lever, boom telescoping control pedal, and head/end boom extension switch. You can adjust the telescoping speed by the operating amount of the boom telescoping/auxiliary hoist control lever and boom telescoping pedal, and the accelerator pedal.

Boom Telescoping Mode

There are 2 boom telescoping modes, "Telescoping mode I" (2nd boom section extends first) and "Telescoping mode II" (3rd/4th/top boom sections extend first). Register one of these telescoping modes to the load moment indicator in the lift state registration process.

-  Before registering the boom telescoping mode, fully retract the boom.
-  For the boom registration, refer to "Registration of Operating State and Load Moment Indicator (AML) Function Check" (page 147).

Boom Telescoping Mode I (2nd Boom Section Extends First)

Compared to the boom telescoping mode II, the capacity increases in the strength capacity zone, but it decreases in the stability zone.

Extend: The 2nd boom is extended to a required length first, then the 3rd, 4th, and top boom sections are fully extended simultaneously.

Retract: The 2nd boom section is retracted to a required length, after the 3rd, 4th, and top boom sections are fully retracted.

Boom Telescoping Mode II (3rd/4th/Top Boom Sections Extend First)

Compared to the boom telescoping mode I, the capacity increases in the stability zone, but it decreases in the strength capacity zone.

Extend: The 3rd, 4th, and top boom sections are fully extended simultaneously, then the 2nd boom section is extended to a required length.

Retract: The 2nd boom section is fully retracted, then the 3rd, 4th, and top boom sections are retracted to a required length.

Telescoping mode I (2nd boom section extends first.)

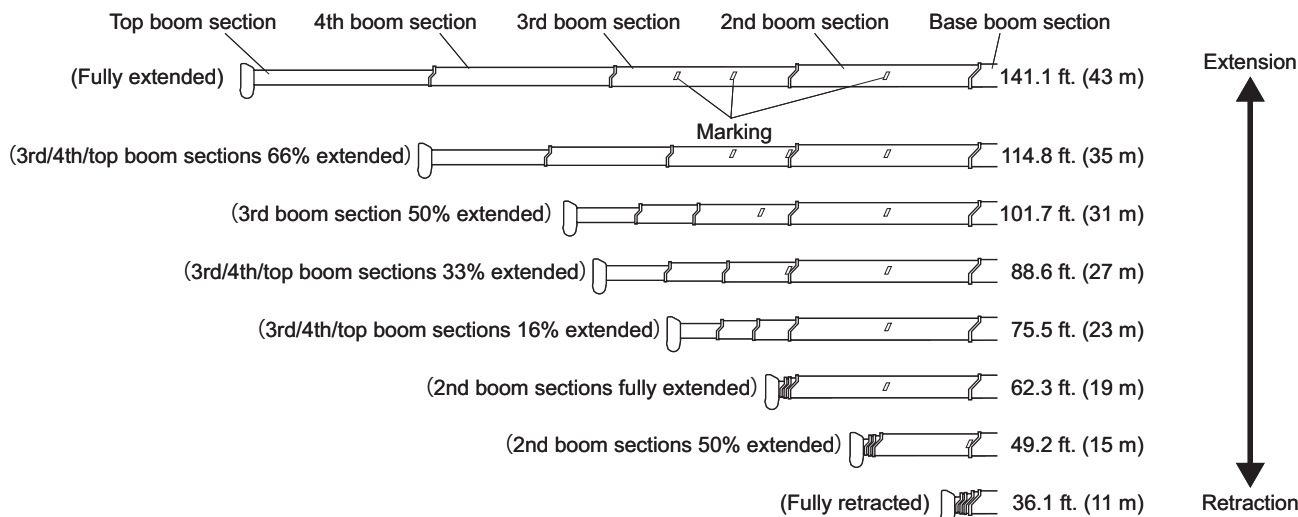

Telescoping mode II (3rd/4th/top boom sections extend first.)

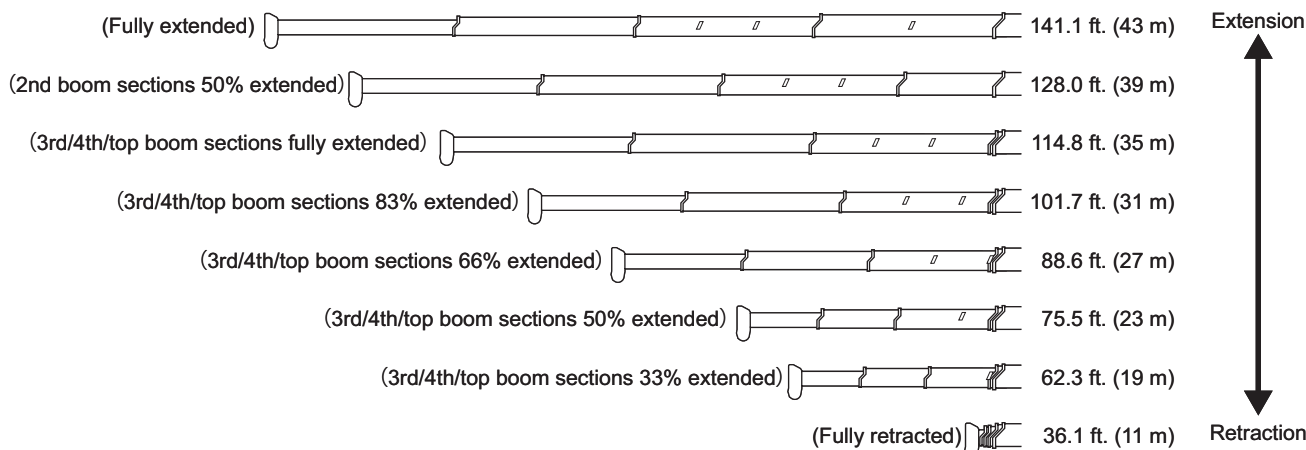

K02929-01E

GR-750XL-2_OM2(U)-17E

Extending the Boom

⚠ WARNING

Before you operate the boom, make sure that the boom telescoping operation mode is selected.

If you operate the lever while the auxiliary hoist control mode is selected, the machine makes an unexpected movement and an accident can occur.

Boom Telescoping Mode I (2nd Boom Section Extends First)

1. Push the "boom telescoping" side of the boom telescoping/auxiliary hoist control selector switch.

- The boom telescoping control icon is highlighted.

 Push down and hold the lock knob, and push the "boom telescoping" switch.

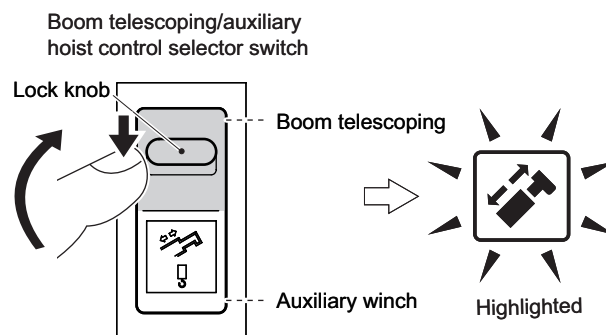

K01909-00E

2. In the pop-up window for operation state registration on the load moment indicator, select "Telescoping mode I". For the boom telescoping mode registration, refer to "Registration of Operating State and Load Moment Indicator Function Check" (page 147).

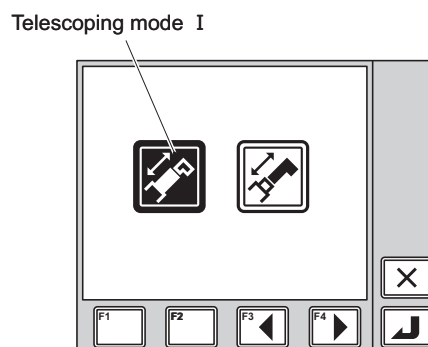

K01415-00E

3. Push the boom telescoping/auxiliary hoist control lever forward, and fully extend the 2nd boom section.
4. While pushing the lever forward, push the head/end boom extension switch.
 - The 3rd, 4th, and top boom sections extend simultaneously.

 Once the 3rd/4th/top boom sections start extending, the extension continues even if the head/end boom extension switch is released.

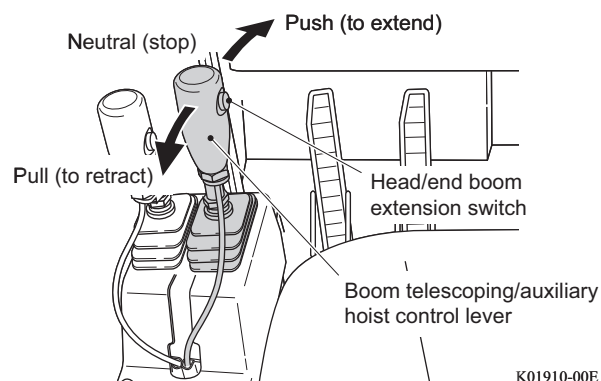

K01910-00E

5. When the boom has extended to a necessary length, pull back the lever to the neutral position.

Boom Telescoping Mode II (3rd/4th/Top Boom Sections Extend First)

1. Push the "boom telescoping" side of the boom telescoping/auxiliary hoist control selector switch.

- The boom telescoping control icon is highlighted.

 Push down and hold the lock knob, and push the "boom telescoping" switch.

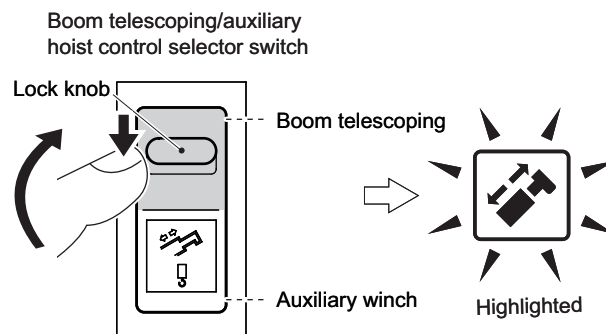

K01909-00E

2. In the pop-up window for load moment indicator operation state registration, select "Telescoping mode II". For the boom telescoping mode registration, refer to "Registration of Operating State and Load Moment Indicator (AML) Function Check" (page 147).

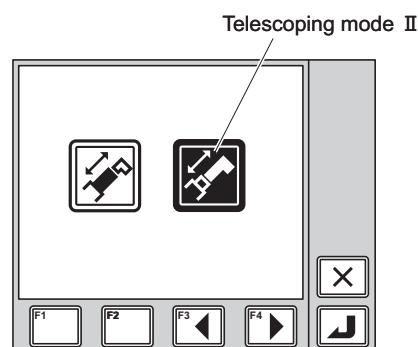

K01416-00E

3. Push the boom telescoping/auxiliary hoist control lever forward, and fully extend the 3rd, 4th and top boom sections.
4. While pushing the lever forward, push the head/end boom extension switch.
 - The 2nd boom section extends.

 Once the 2nd boom section starts extending, the extension continues even if the head/end boom extension switch is released.

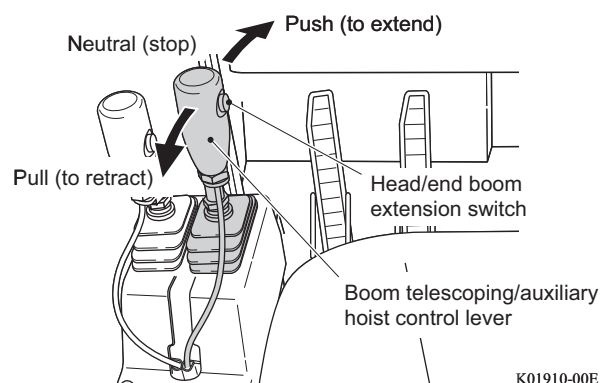

K01910-00E

5. When the boom has extended to a necessary length, pull back the lever to the neutral position.

Retracting the Boom

Boom Telescoping Mode I (2nd Boom Section Extends First)

1. Pull the boom telescoping/auxiliary hoist control lever backward, and fully retract the 3rd, 4th and top boom sections.
 - After the 3rd, 4th, and top boom sections are fully retracted, the 2nd boom section is retracted.
2. When the boom has retracted to a necessary length, push back the lever to the neutral position.

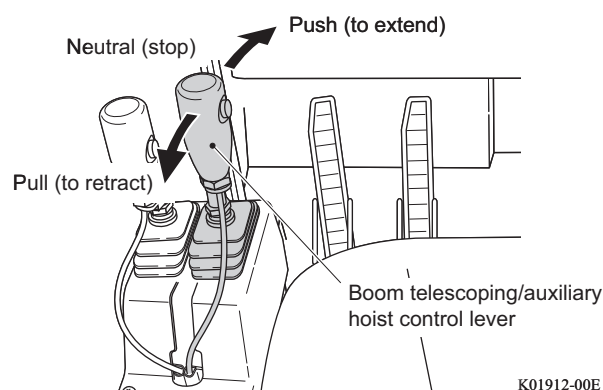

Boom Telescoping Mode II (3rd/4th/Top Boom Sections Extend First)

1. Pull the boom telescoping/auxiliary hoist control lever backward, and fully retract the 2nd boom section.
 - After the 2nd boom section is fully retracted, the 3rd, 4th, and top boom sections are retracted.
2. When the boom has retracted to a necessary length, push back the lever to the neutral position.

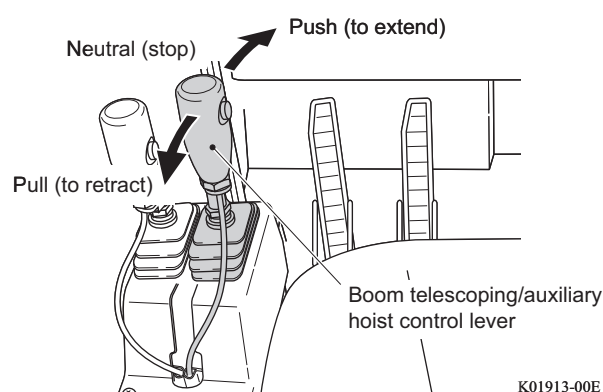

Boom Telescoping Control Pedal

This pedal is used to extend and retract the boom.

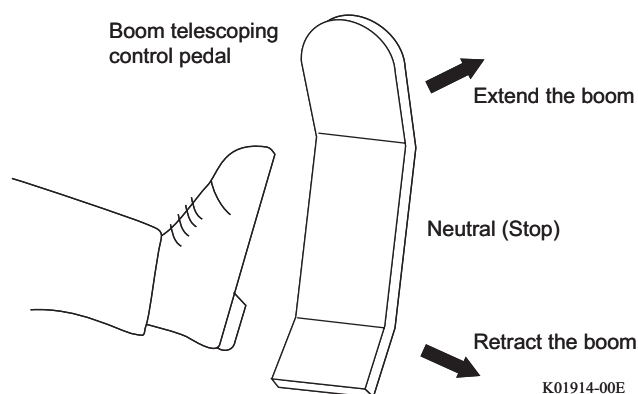

Elevating the Boom

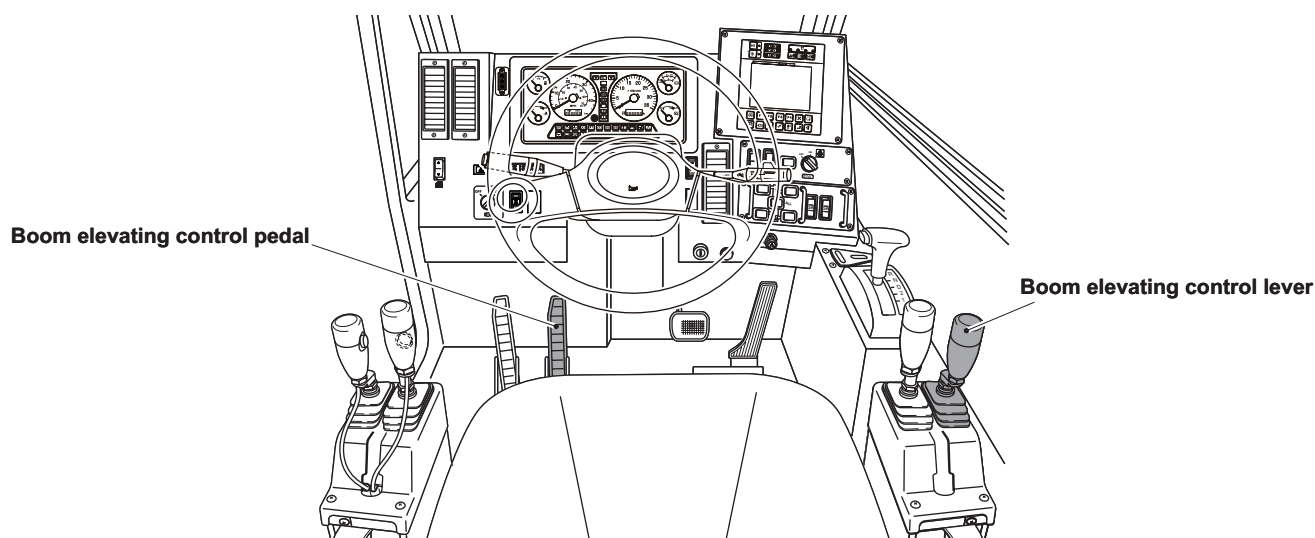

K07037-00E

Boom Raising/Lowering Operation

⚠ DANGER

Do not put your arm or head out of the window during crane operation. You can be caught between the boom and the cab, resulting in a fatal and serious accident.

⚠ WARNING

- Abrupt lever operation can cause the load to bounce or sway, resulting in an accident causing injury or death, or machine damage. Operate the levers slowly.
- Never lift a load off the ground or pull in a load by boom raising operation. The machine can overturn or be damaged. Lift a load off the ground by the hoisting up operation.

The boom elevating is controlled by operating the boom elevating control lever and boom elevating control pedal.

The boom elevating speed is adjusted by the operating amount of the boom elevating control lever and boom elevating control pedal, and the accelerator operation.

- Boom lowering … Push the lever forward.
- Stop …………… Pull back the lever to the neutral position.
- Boom raising …… Pull the lever backward.

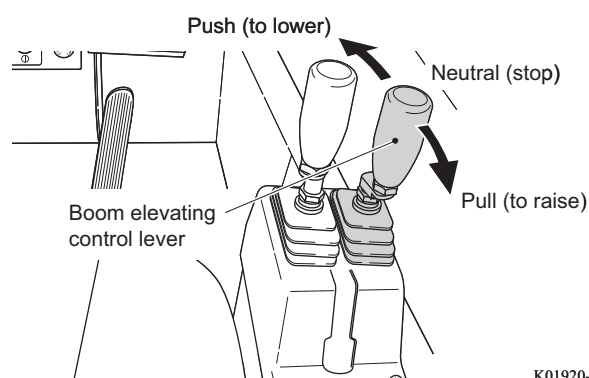

K01920-00E

NOTICE

Note that when the boom angle is steep, abrupt boom elevation can cause the hook block or the lifted load to hit the boom elevating cylinder, boom, or jib. This can result in a machine damage.

Boom Elevating Control Pedal

This pedal is used to raise or lower the boom.

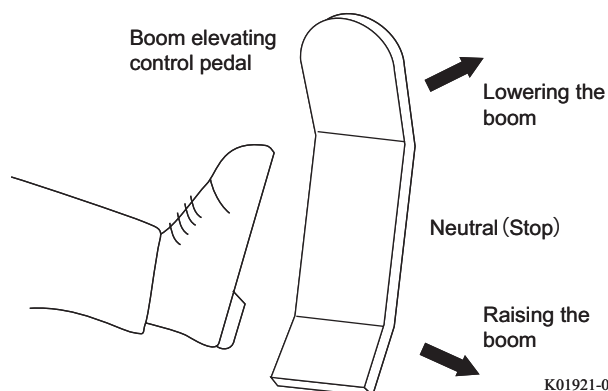

K01921-00E

Elevation Slow Stop Function

This function reduces the load sway by decelerating the boom elevating speed before the boom elevation is stopped.

Swinging the Boom

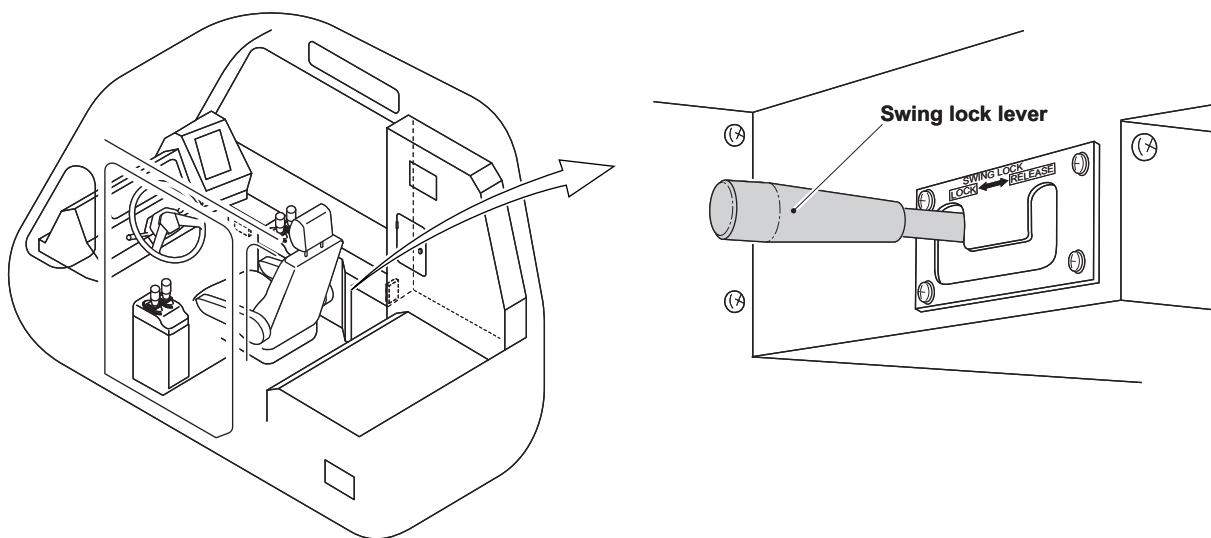
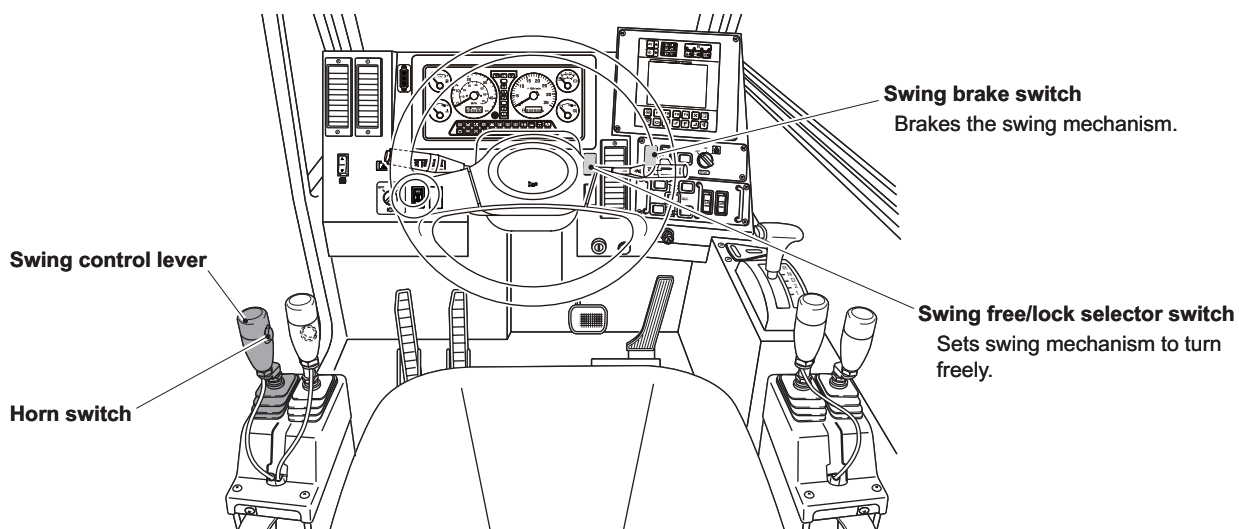

K07038-00E

Swinging the Boom

⚠ WARNING

- Never drag a load sideways by swing operation. The machine can be damaged, resulting in an accident.
- Before swinging the boom, push the horn switch to alert the people around the machine to prevent an accident.

The swing operation is performed by operating the swing lever.

The swing speed is adjusted by the travel amount of the swing lever and the accelerator.

1. Set the swing lock lever to "RELEASE."

- The swing lock pin is released.

 If the swing lock pin does not come out, swing the boom slightly, and then operate the swing lock lever again.

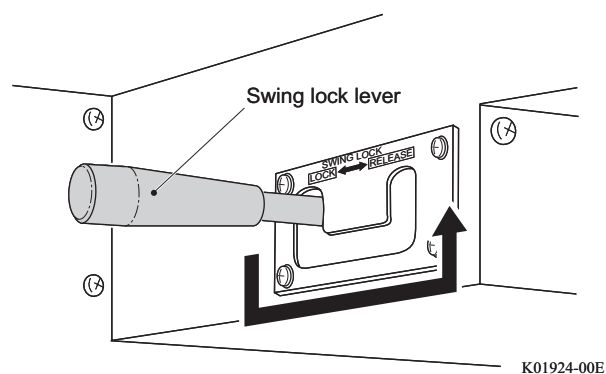

2. Push the "OFF" side of the swing brake switch to release the swing brake.

- The swing brake switch lamp goes out.

Swing brake switch

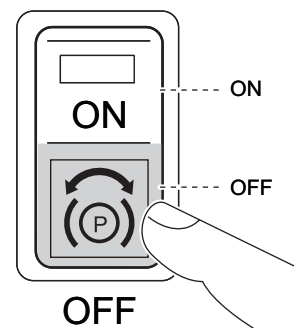

3. Before you operate the swing control lever, push the horn switch to sound the horn, and alert the people around the machine.

4. Operate the swing control lever to swing the boom.

- Left swing Pull the lever backward.
- Stop Push back the lever to the neutral position.
- Right swing Push the lever forward.

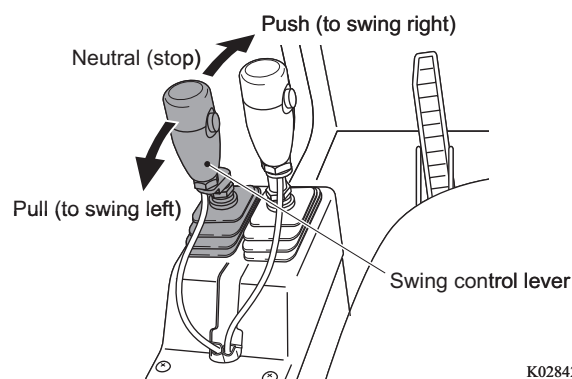

K02842-00E

⚠ WARNING

Abrupt operation can cause the load to bounce or sway, resulting in an accident causing injury or death, or machine damage. Operate the levers slowly.

NOTICE

Do not set the swing lock lever to "LOCK" during swing operation. The machine can be damaged.

5. After the swing operation, push the "ON" side of the swing brake switch.

- The swing brake switch lamp lights up.

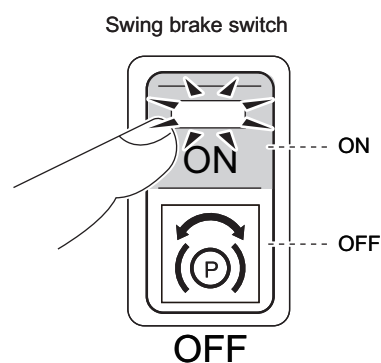

K01926-01E

Swing Free/Lock Selector Switch

NOTICE

- Do not operate the swing free/lock selector switch during the swing operation. The machine can be damaged.
- Be careful about the swing speed while the swing free function is enabled. The swing does not stop immediately because of the inertia force even if you return the swing control lever to the neutral position.

This switch is used to activate the swing free function.

- "ON": Free The swing free function is enabled.
- "OFF": Lock The swing free function is disabled.

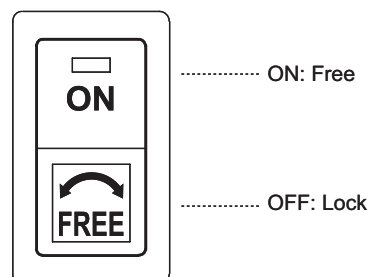

K01927-01E

You can perform the operations below while the swing free function is enabled.

- (1) When a load is hoisted up, the superstructure turns in the direction of the load and becomes aligned with the load.
- (2) When the boom is swung with a load lifted and the control lever is returned to the neutral position, the boom continues swinging by the inertia force.

 The swing free function can be locked by retracting the operation lever stand while the swing free/lock selector switch is on.

The swing lock is released by placing the operation lever stand back to the operation position.

Automatic Swing Stop Function

WARNING

Automatic swing stop function does not work during on-rubber operation. If overload occurs during swinging, the machine can overturn or be damaged. During on-rubber operation, be careful when you swing the machine not to cause overloading.

This function automatically halts the swing movement to prevent overturning of the machine.

This function works in the cases below:

- The extension width of the outriggers is unequal and a swinging operation causes overloading.
- The swing range limit for the work range limit function is registered on the load moment indicator.

 When this function works, only swing operation slows down to a stop and other movements continue.

On-rubber Operation

⚠ WARNING

To prevent overturning of and damage to the machine, observe the following procedures:

- Check that air pressure in the tires is at the specified value (refer to "Service Data" [page 455]). If the machine is operated while the air pressure is out of specification, the tires can burst.

- The swing automatic stop function does not work. If an overload occurs during swinging, the machine can overturn. When lifting a load in the over-front area and swing it to the side or rear, check that an overload does not occur.

The over-front area in the rated lifting capacity table is specified as within approximately 2° in front of the machine.

And when the boom is in this area, the front position symbol appears on the load moment indicator.

When a boom is swung from the over-front area to the over-side area, the rated lifting capacity decreases. When you swing the boom with a load lifted, make sure that the load is limited within the rated lifting capacity for 360-degree area.

- The rated lifting capacity for on-rubber operation assumes that the machine is set up on a level and rigid ground. Never perform the crane operation on an inclined or soft ground.

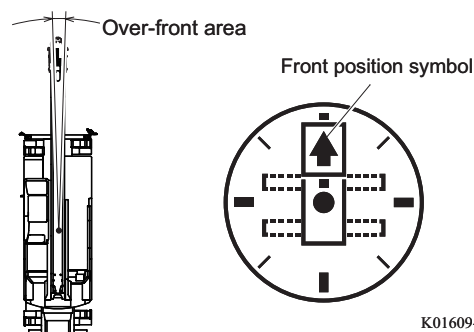

K01609-00E

NOTICE

The machine is supported by the tires in on-rubber operation. The load sways easily by the deflection of the tires. Operate the crane slowly and safely.

On-rubber Stationary Operation

1. Direct the boom to the over-front.
2. Register the on-rubber stationary operation status to the load moment indicator.

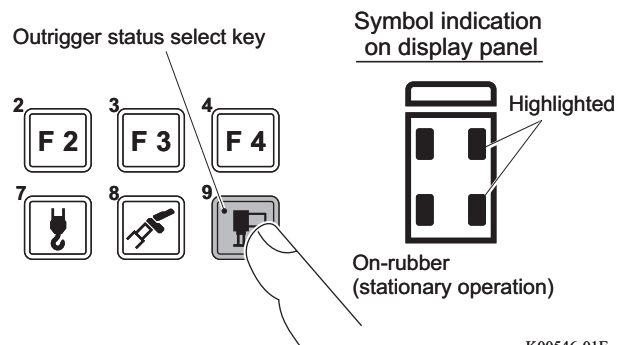

3. Register the lift status (single top/boom) to the load moment indicator.

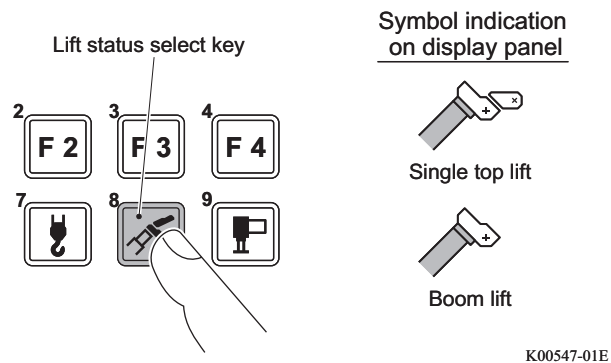

Now the machine is ready for on-rubber stationary operation.

On-rubber Creep Operation

⚠ WARNING

Observe the following in order to prevent the machine from overturning over or being damaged.

- For safety, keep the lifted load close to the ground, and support it with an auxiliary rope, etc. to restrain the swaying of the load during traveling.
- Keep the PTO switch "ON" so that the crane can be immediately operated during traveling in order to prevent danger.
- Never operate the crane during on-rubber creep operation with a load lifted. Stop traveling before operating the crane.
- Travel at a speed of 1 mph (1.6 km/h) or less (very slow speed), and restrict the moving distance to 200 ft. (60 m) or less per 30 minutes.
- Avoid rough operations such as sudden start/stop, abrupt steering, etc. Such actions cause the load to sway.

1. Direct the boom toward the over-front.
2. Register the on-rubber creep operation to the load moment indicator.

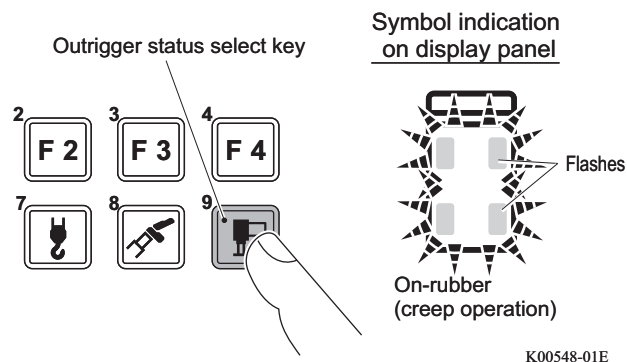

3. Register the lift status (single top/boom) to the load moment indicator.

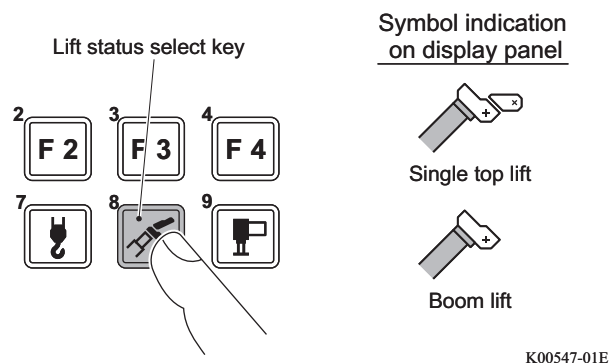

4. Lift a load.

5. Set the swing brake switch to "ON".
- The swing brake is applied.

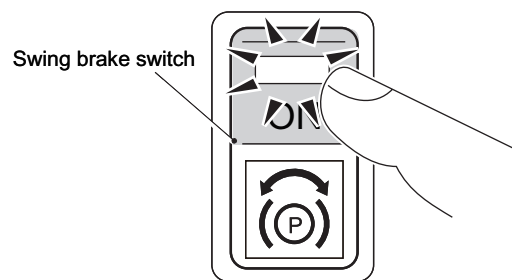

K01286-00E

6. Set the parking brake switch to "OFF".
- The brake warning goes out.

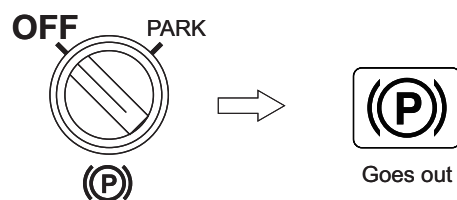

K01288-01E

Now the machine is ready for on-rubber creep operation.

Taking Out and Stowing the Hook Block

Taking Out the Main Hook Block

1. Extend the outriggers, and set up the machine horizontally.

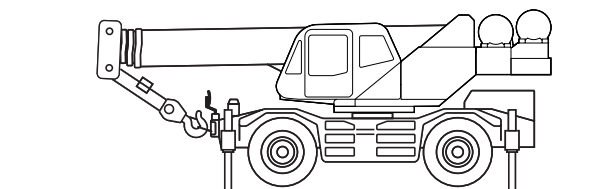

K02868-000

2. Raise the boom and unwind the main winch simultaneously until the boom head comes right above the main hook block.

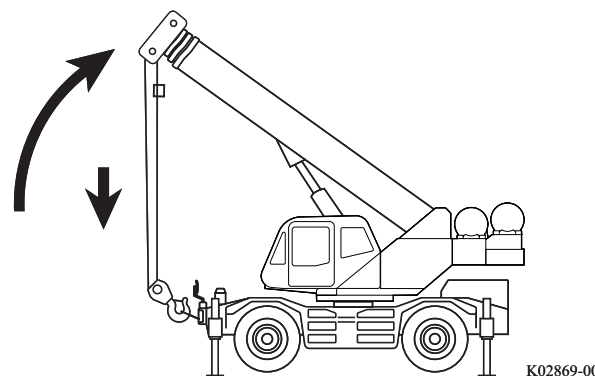

K02869-000

3. Detach the hook retaining rope from the main hook block.

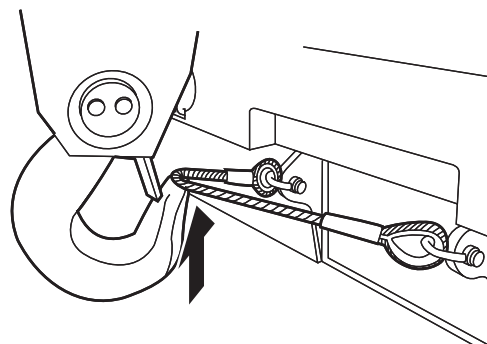

K00550-000

4. Make sure that the wire rope is not disorderly wound on the drum.

Stowing the Main Hook Block

1. Fully retract the boom.
2. Raise the boom and unwind the main winch simultaneously until the main hook block comes to the stowing position.

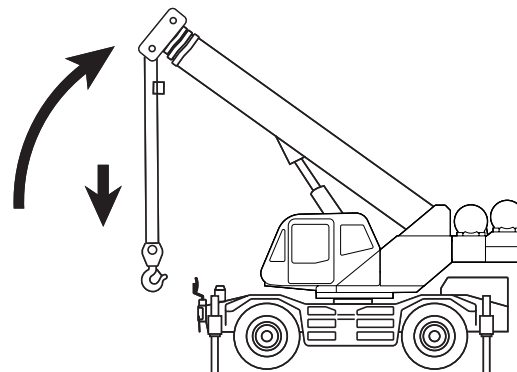

K02870-000

3. Attach the hook retaining rope on the main hook block.

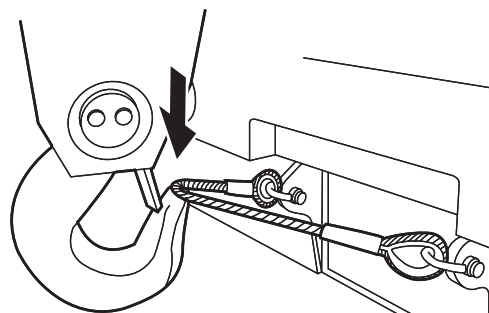

K01614-000

4. While lowering the boom and winding up the main winch simultaneously, set the boom into the traveling configuration.

 If you cannot stow the hook block because of the activation of anti-twoblock device, press and hold the anti-twoblock disable switch to stop the function, and stow the hook block.

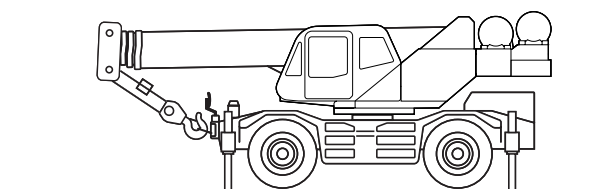

K02868-000

5. Wind the main wire rope until it is tensioned slightly.

NOTICE

It you wind the wire rope excessively, the wire rope and the hook retainer rope can be damaged.

Reeving the Wire Ropes

Standard Number of Parts of Line

⚠ WARNING

- If the crane is operated with more number of parts of line than the standard, the wire rope length can become insufficient. If the entire length of wire rope on the winch drum is reeled out, the load will be then applied to the end of the wire rope. This can break the wire rope and cause an accident. Or the wire rope can be wound up in the opposite direction. In this situation, the hook block is hoisted up during winch hoist-down operation, this also can cause an accident. Select the number of parts of line so that 3 or more dead turns of rope always remain on the winch drum.

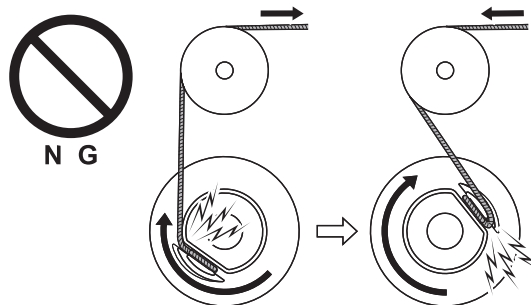





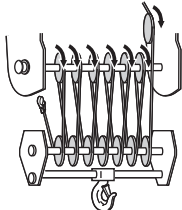
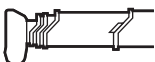
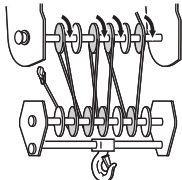
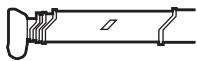
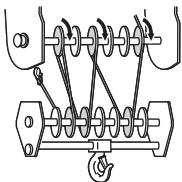

G45012-00E

- If the number of parts of line used is less than the standard, the load cannot be lifted as specified in the rated lifting capacity table. If a load heavier than the allowable load is lifted up, the wire rope can break and cause an accident. Make sure that the allowable load per one wire rope (12,300 lbs [5,600 kg] or less for both main and auxiliary wire ropes) is not exceeded.

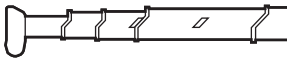
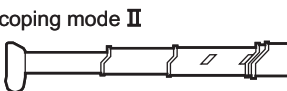
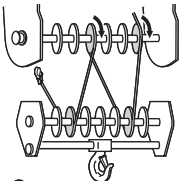
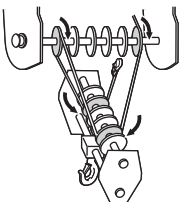

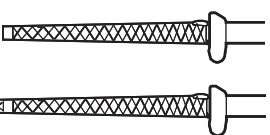

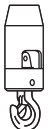

Select an optimum number of parts of line according to the boom length, lifting capacity, and hoisting speed.

On-outrigger Operation

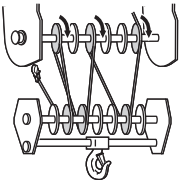
Boom length and standard number of parts of line	Reeving pattern	Hook block to be used, hook mass	Allowable load of rope
<p>36.1 ft. (11.0 m); 14 parts of line</p> 	<p>14 parts of line Mount the single top.</p> 		
<p>36.1—49.2 ft. (11.0—15.0 m); 8 parts of line Telescoping mode I</p> 	<p>8 parts of line</p> 		
<p>49.2—62.3 ft. (15.0—19.0 m); 6 parts of line Telescoping mode I</p> 	<p>6 parts of line</p> 	<p>Main hook block 75 short tons (68.0 metric tons) : 7 sheaves</p> 	<p>12,300 lbs (5600kg) /part of line</p>
<p>62.3—141.1 ft. (19.0—43.0 m); 4 parts of line Telescoping mode I</p>  <p>49.2—141.1 ft. (15.0—43.0 m); 4 parts of line Telescoping mode II</p> 	<p>4 parts of line</p>  <p>Or</p> 	<p>1,300 lbs (590 kg)</p>	
<p>Single top lift.: 1 part of line</p>  <p>Jib lift.: 1 part line</p> 		<p>Auxiliary hook block 6.2 short tons (5.6 metric tons)</p>  <p>330 lbs (150 kg)</p>	<p>12,300 lbs (5600kg) /part of line</p> <p>K02935-03E</p>

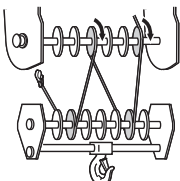
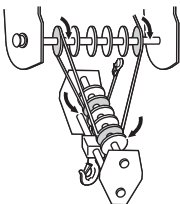
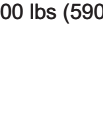
GR-750XL-2_OM2(U)-17E

On-rubber Operation

Boom length and standard number of parts of line	Reeving pattern	Hook block to be used, hook mass	Allowable load of rope
<p>36.1 ft. (11.0 m); 6 parts of line</p> 	<p>6 parts of line (Over-front area)</p> 	<p>Main hook block 75 short tons (68.0 metric tons) : 7 sheaves</p> 	
<p>36.1—88.6 ft. (11.0—27.0 m); 4 parts of line</p> <p>Telescoping mode II</p> 	<p>4 parts of line (360-degree area capacity)</p>  <p>Or</p> 	<p>1,300 lbs (590 kg)</p> 	<p>12,300 lbs (5600kg) /part of line</p>
<p>Single top lift.: 1 part of line</p> 		<p>Auxiliary hook block 6.2 short tons (5.6 metric tons)</p>  <p>330 lbs (150 kg)</p>	<p>12,300 lbs (5600kg) /part of line</p>

K02936-03E

Reeving Procedure

CAUTION

- Do not stand in the direction to which the hook block may tumble down. A tumbling hook block can cause an injury. When you work, always stand in a direction in which the hook block does not tumble.
- When reeving the wire rope, wear thick leather gloves. Otherwise, you may suffer an injury.



G45002-00E

1. Set up the outriggers, and slew the boom in a direction where operation can be easily performed.
2. Raise the boom, and reel out the wire rope by the winch wind-down operation.

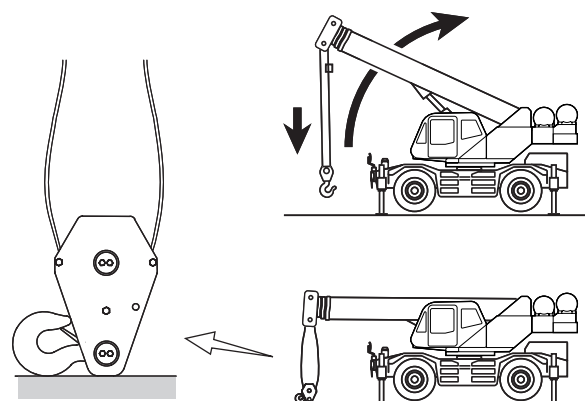

K02871-000

3. Set the boom horizontally, and stand the hook block on the ground as shown in the illustration.
4. Remove the weight for the anti-twoblock device from the wire rope.

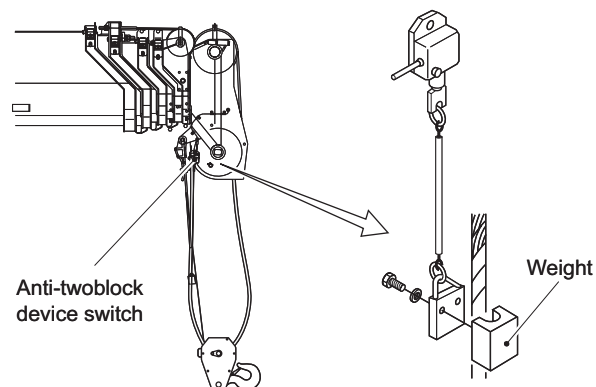

K02587-00E

5. Remove the snap pins, and pull out the two rope guide pins.

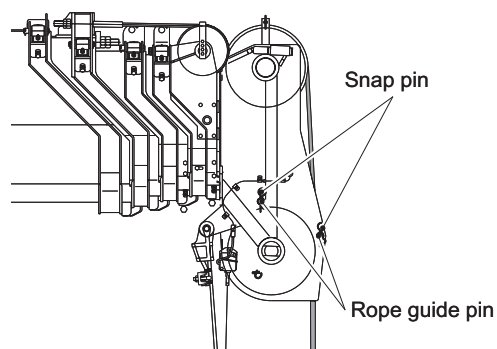

K03079-00E

6. Remove the bolts from the main hook block.

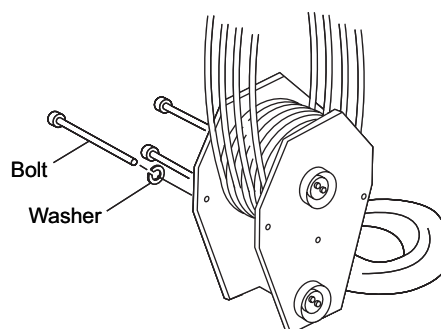

K04050-00E

7. Remove the rope socket from the boom.

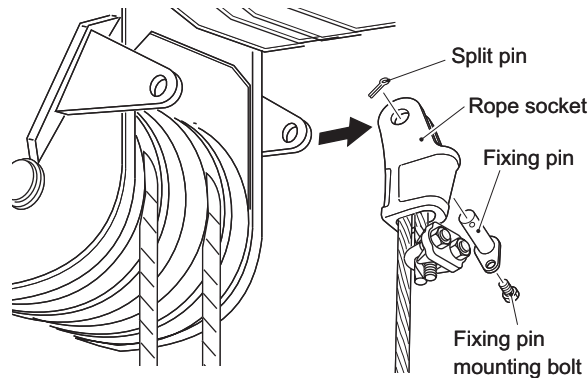

K03080-00E

8. Refer to the "Standard Number of Part Line" (page 227), and reeve the wire rope again.

For using a 75 short tons (68.0 metric tons) hook block with a 14 part line pattern, refer to the "Single Top" section (page 235) and mount the single top. After reeving the wire rope on the single top, attach the rope guide pin (1 point). Then secure the guide pin using a snap pin.

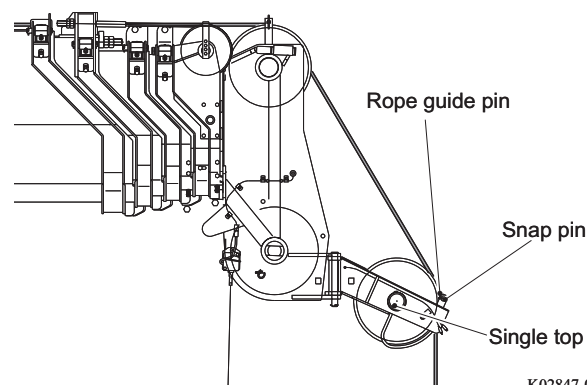

K02847-00E

9. Mount the rope socket as shown in the illustration.

⚠ WARNING

Securely tighten the fixing pin mounting bolt for the rope socket using a wrench. After attaching the fixing pin, secure it using a split pin so that the fixing pin does not come out.

Improper installation can cause the rope socket to come off and the lifted load to fall, resulting in an accident.

- ☞ Install the rope socket to the right or left side of the boom according to the "Standard Number of Parts of Line" (page 227).

To attach the rope socket to the right of the boom

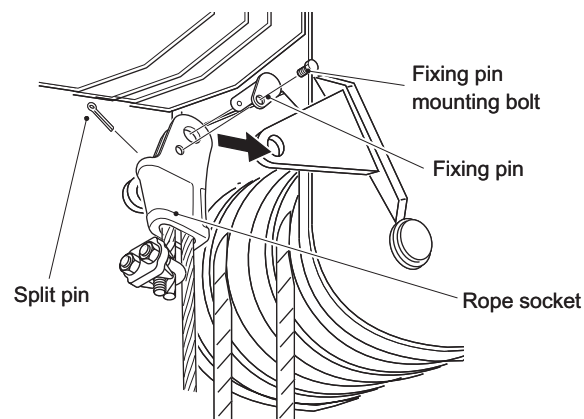

To attach the rope socket to the left of the boom

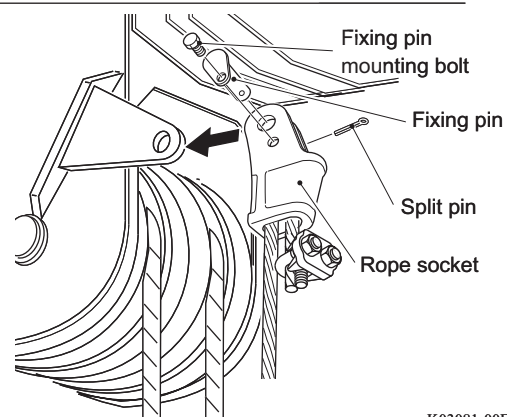

K03081-00E

10. Install the weight for the anti-twoblock device to the wire rope on the rope socket side.

⚠ WARNING

Tighten the bolt securely using a wrench. Improper installation can cause the weight to fall, resulting in an injury.

☞ If it is necessary to attach a rope socket to the left side of the boom, interchange the anti-twoblock detection switch and connector (a) as shown in the illustration.

When rope socket is installed to the right side of boom

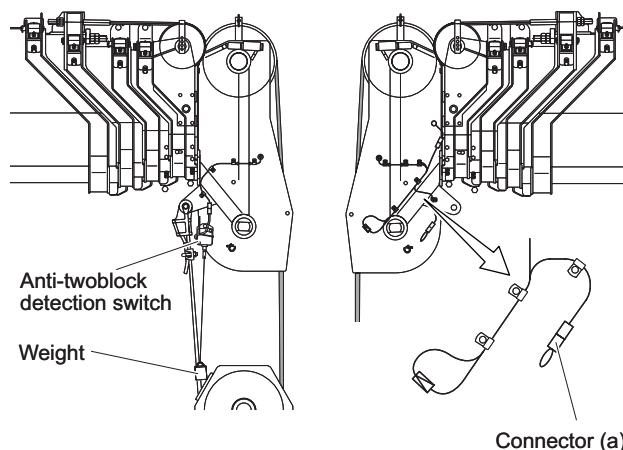

When rope socket is installed to the left side of boom

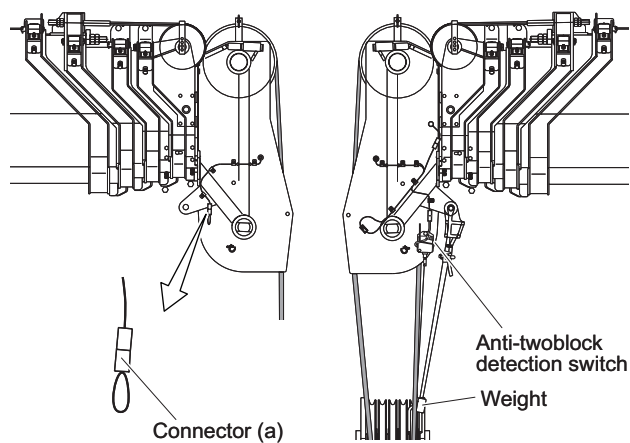

K03534-01E

11. Install the rope guide pins (2 points) to the boom head, and secure them with snap pins.

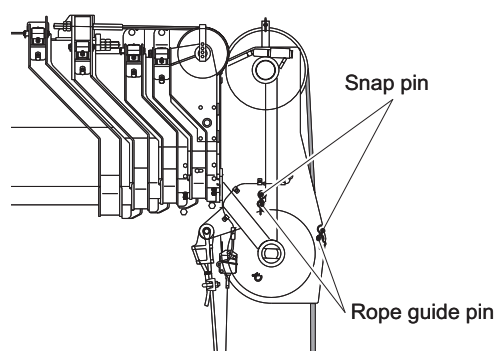

K02846-00E

12. Install the bolts on the main hook block.

⚠ WARNING

Securely tighten the bolts using a wrench. Improper installation can cause the wire rope to come off, resulting in an accident.

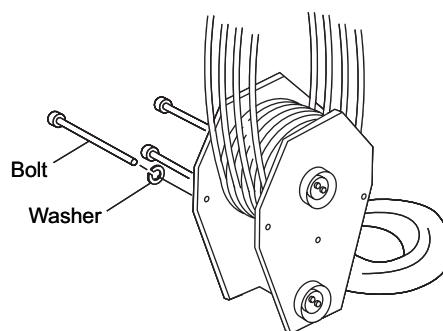

K04050-00E

13. Raise the boom until the load lines become tense, and wind the wire rope on the winch drum by the hoist-up operation.

NOTICE

Disorderly winding can damage the wire rope. When the wire rope is wound up disorderly, rewind it.

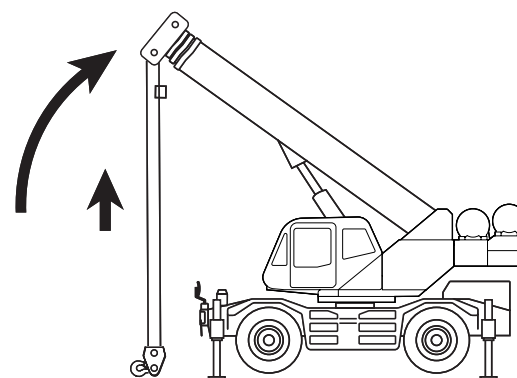

K02872-000

14. Register the boom lift status to the load moment indicator.

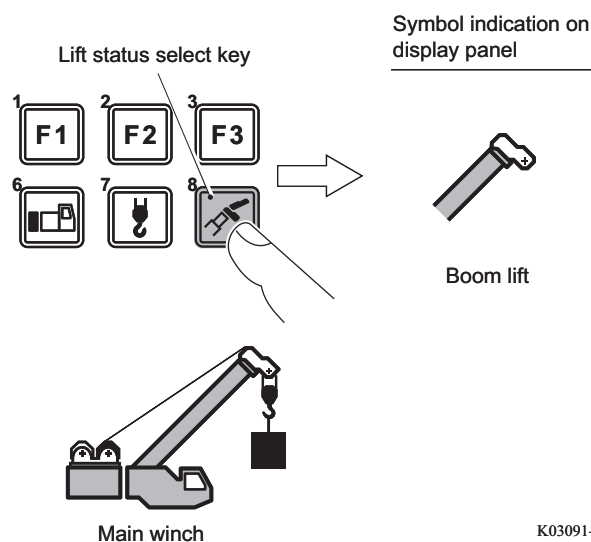

K03091-01E

15. Check that the crane automatically stops when the main hook block is overhoisted.

☞ If the crane does not stop automatically, refer to Step 10 and check that the weight for the anti-two-block device is installed correctly.

Now, the reeving of the wire ropes is completed.

Single Top

The single top is mounted on the boom head. The single top allows quicker hoisting up and down operations, because it works with one part line.

Normally, the single top is operated with the main winch. However, the auxiliary winch can also be used.

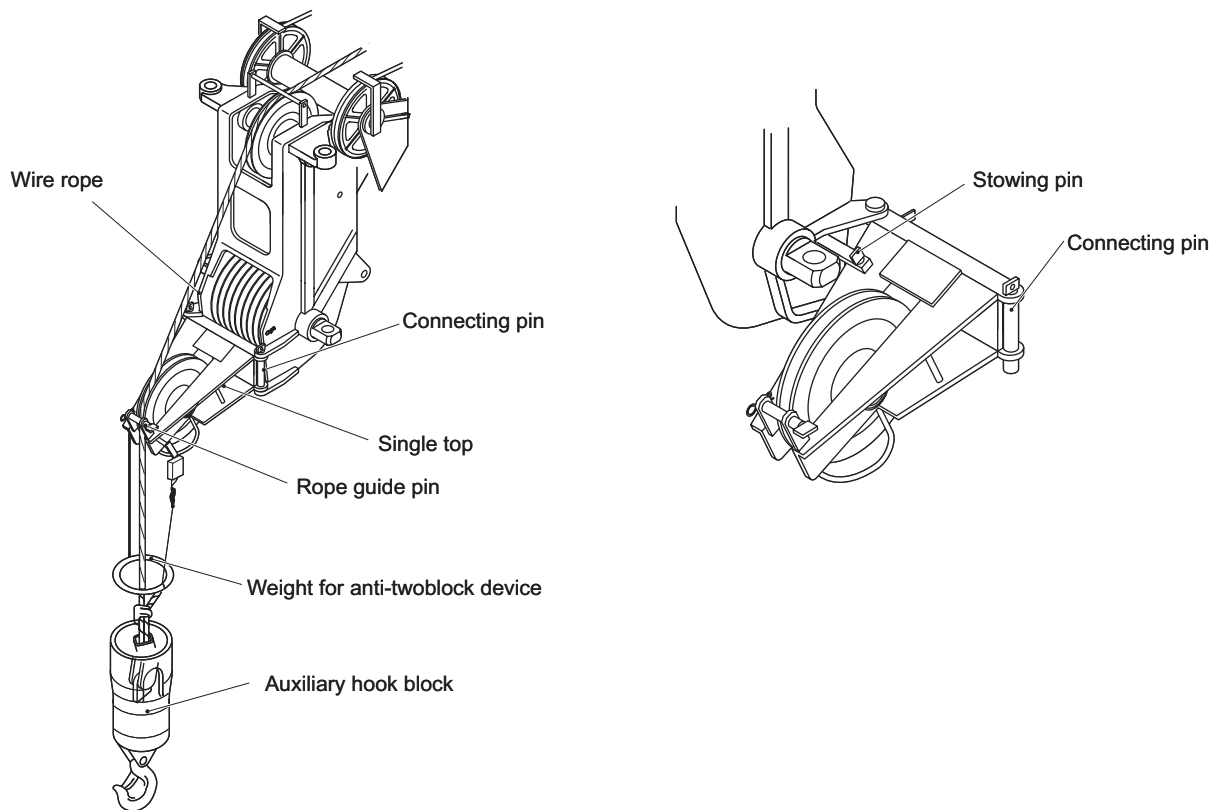

K02948-00E

Mounting Single Top

⚠ WARNING

If you work at an elevated place, use a platform to prevent a falling accident.

1. Extend the outriggers, and set up the crane horizontally.

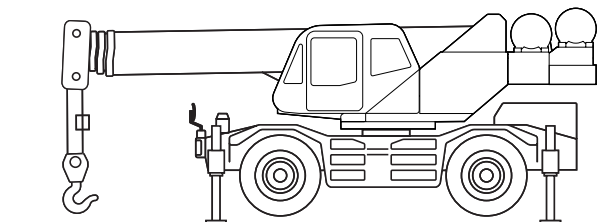

K02850-000

2. Set the boom angle to 0°.

3. Remove the main wire rope from the hook block, and reeve the wire rope through the sheave on the upper side of the top boom section.

☞ For removal of the wire rope, refer to "Reeving the Wire Ropes" (page 227).

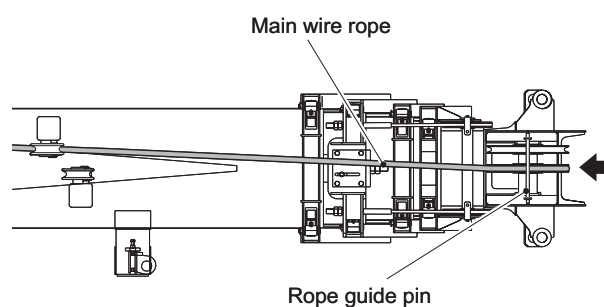

K02851-00E

☞ To carry out a single top lift operation using the auxiliary winch, follow the procedure below.

- (1) Remove the auxiliary wire rope from the rope arrester, and put the wire rope on the top side of the boom.

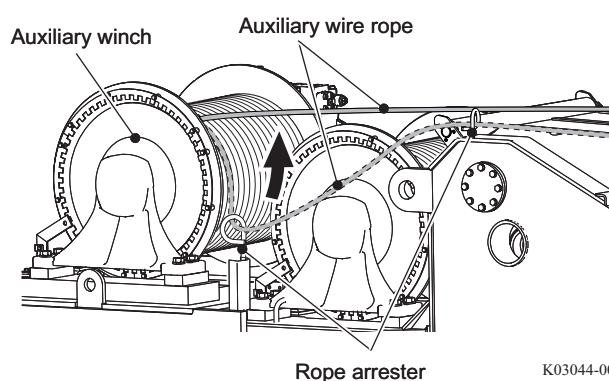

K03044-00E

- (2) Pull out the fixing pin, and remove the rope socket for the auxiliary wire rope from the support on the jib.

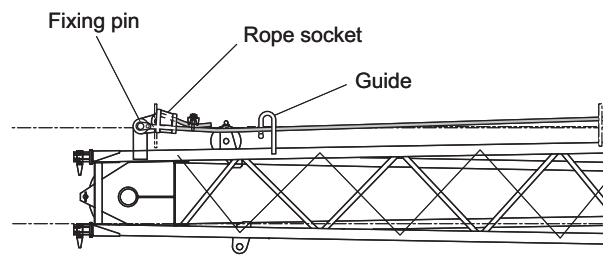

K02853-00E

- (3) Reeve the wire rope through the sheave on the upper side of the top boom section.

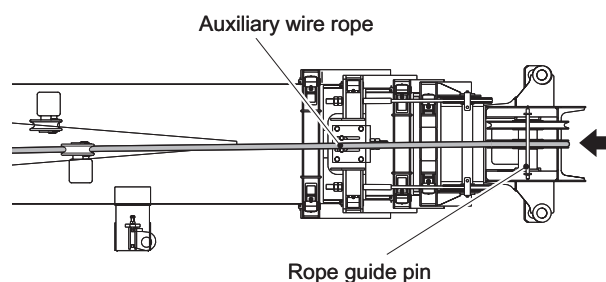

K02854-00E

- 4. Pull out the stowing pin, and rotate the single top toward the front of the boom.

CAUTION
 Do not stand in the direction the single top rotates. The single top can swing suddenly by its own weight. This can cause an injury.

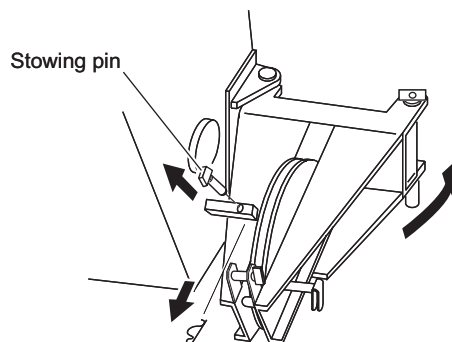

K02855-00E

Insert the stowing pin to the original position.

- 5. Insert the connecting pin to fix the single top to the boom, and insert the snap pin.

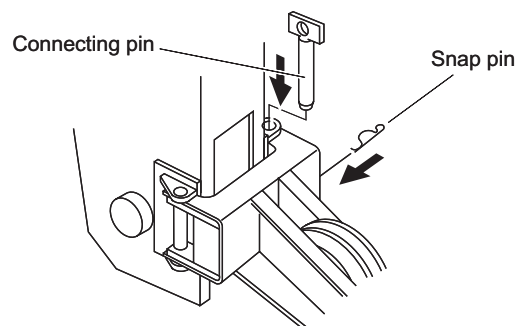

K02859-00E

6. Reeve the wire rope through the sheave of the single top, and then insert the rope guide pin next to the sheave of the single top.

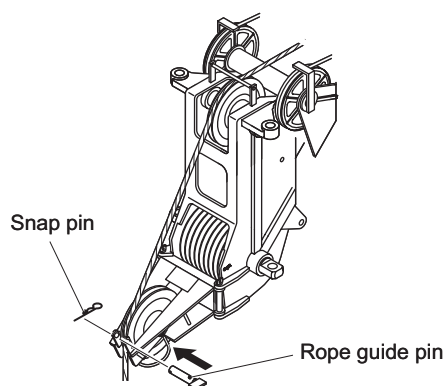

K02856-00E

7. Take out the anti-two block device from the tool box, and reeve the wire rope through the weight for the anti-two block device.

8. Mount the anti-two block device to the single top.

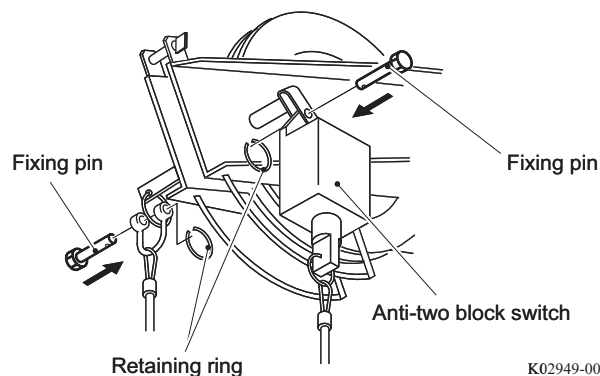

K02949-00E

9. Connect the connectors (4 points) for the anti-two block device.

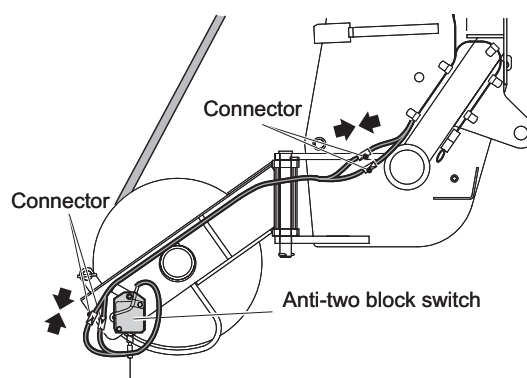

K02950-00E

10. Hang the weight on the support on the boom head, and insert the pin through the rod of the twoblocking detection switch in order that the anti-two block device for boom lift does not activate.

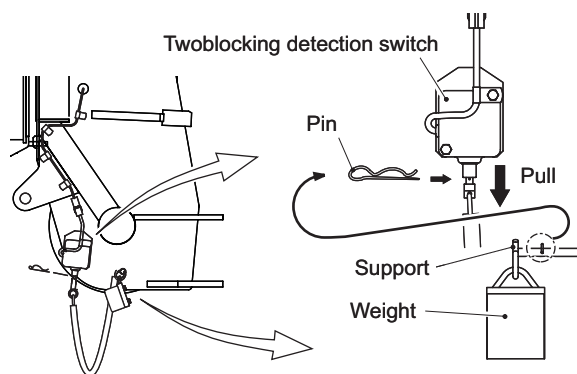

K02951-00E

11. Insert the fixing pin and secure the rope socket to the auxiliary hook block.

⚠ WARNING

Securely tighten the fixing pin mounting bolt for the rope socket using a wrench. Secure the fixing pin by using a split pin so that it does not come out. Improper installation can cause the rope socket to come off and the lifted load to fall, resulting in an accident.

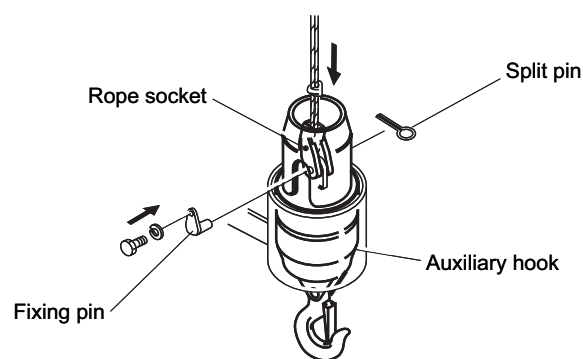

G46010-00E

12. Hoist up the auxiliary hook block and take it out from the stowing position.

13. Register the single top lift status to the load moment indicator.

☞ To use the auxiliary winch, refer to "Registration of Operating State and Load Moment Indicator (AML) Function Check" (page 147), and change the load moment indicator setting accordingly.

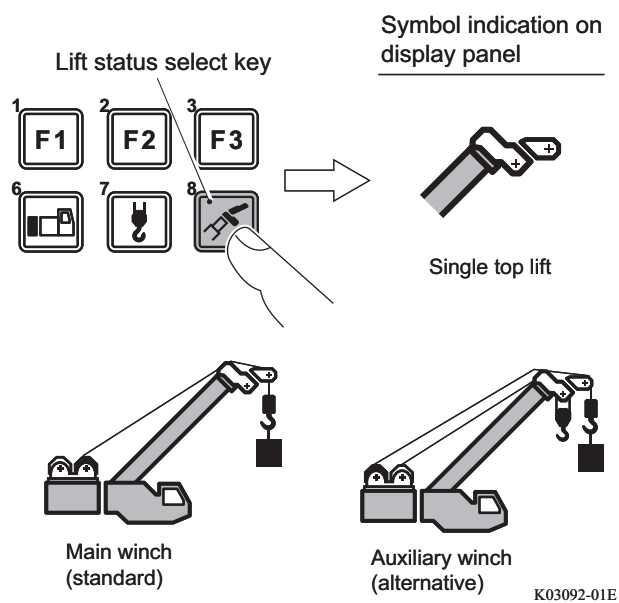

K03092-01E

14. Check that the crane automatically stops when the hook block is overhoisted.

☞ If the crane does not stop automatically, refer to Step 9 and check that the wiring is connected correctly.

Now, the mounting of the single top is completed.

Stowing Single Top

⚠ WARNING

If you work at an elevated place, use a platform to prevent a falling accident.

1. Stow the auxiliary hook block in the stowing position.
2. Remove the fixing pin. And then remove the rope socket from the auxiliary hook block.

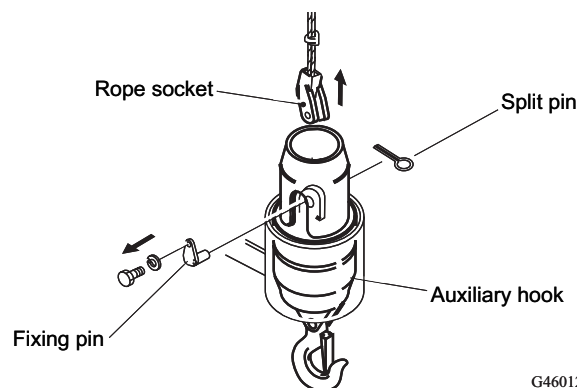

G46012-00E

4. Connect/disconnect the wire for the anti-two block device as shown in the figure.

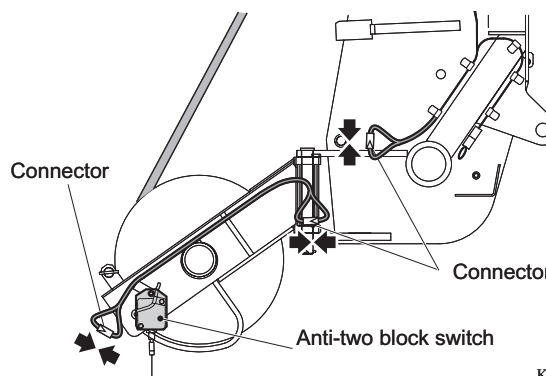

K02952-00E

5. Remove the anti-two block device, and return it to the tool box.
6. Remove the weight from the support on the boom head and remove the pin from the rod for the twoblocking detection switch so that the anti-two block device for boom lift can be activated. Stow the removed pin in the support.

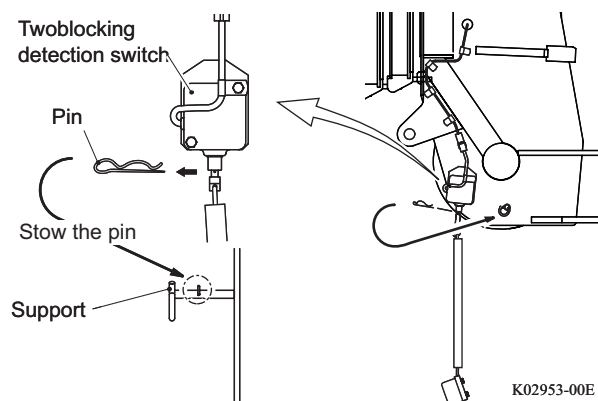

K02953-00E

⚠ WARNING

If the pin inserted in the rod for twoblocking detection switch is not removed, the anti-two block device for the main winch does not function during boom lift. The hook block can collide with the boom and cause the lifted load to fall, resulting in a serious accident. Before the boom lift, make sure that the anti-twoblock device functions correctly.

7. Remove the stowing pin from the sheave of the single top.

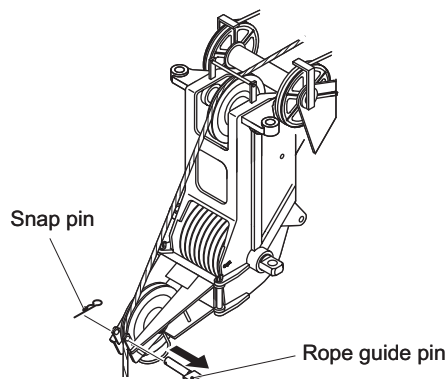

K02861-00E

8. Remove the wire rope from the sheave of the single top.

9. Reeve the main wire rope through the sheave for boom lift.

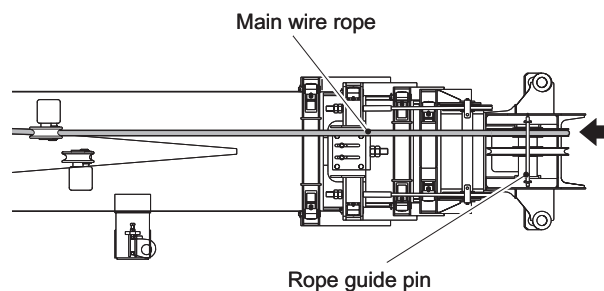

K02862-00E

☞ After the single top lift using the auxiliary winch, follow the procedure below.

(1) Remove the auxiliary wire rope from the boom, and pass the wire rope on the rope arrester.

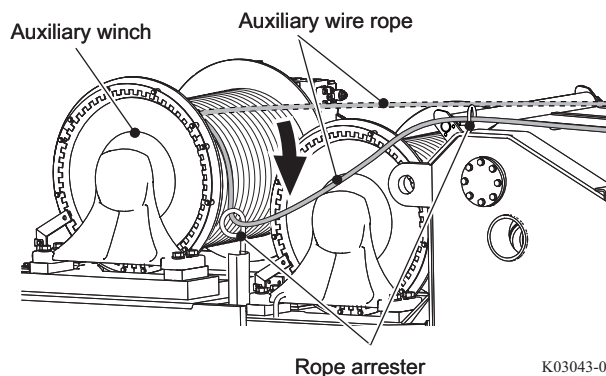

K03043-00E

(2) Mount the rope socket for auxiliary wire rope to the support on the jib.

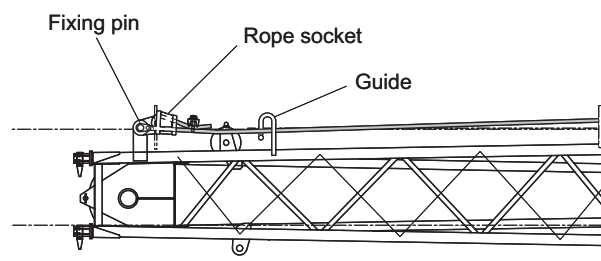

K02853-00E

- (3) Route the auxiliary wire rope as shown in the figure.

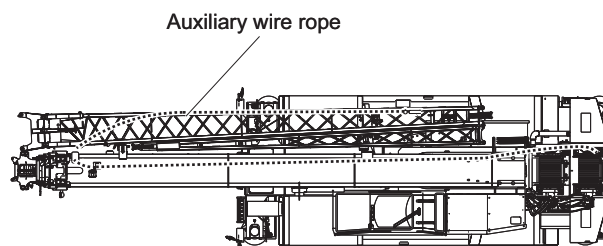

K07056-00E

- (4) Wind up the auxiliary wire rope to loosen the wire rope slightly.

NOTICE

- Do not wind up the auxiliary wire rope excessively. The support on the jib can be damaged.
- Make sure that the auxiliary wire rope is loosened when stowed. If the rope is kept tensioned, the rope arrester can be damaged when the boom is raised.

10. Pull out the connecting pin, and rotate the single top and stow it.

CAUTION

Do not stand in the direction the single top rotates. The single top can swing suddenly by its own weight. This can cause an injury.

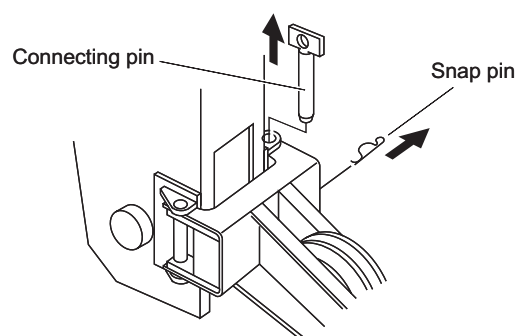

K02864-00E

11. Insert the stowing pin to secure the single top. Insert the connecting pin into the original position, and secure it with the snap pin.

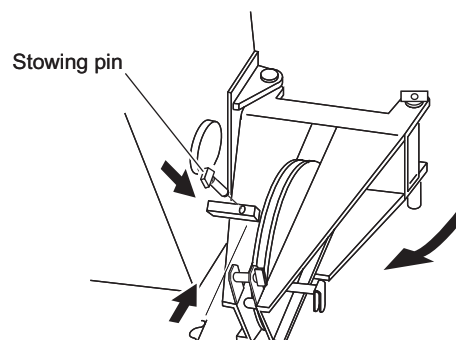

K02865-00E

- 12.** Register the boom lift status to the load moment indicator.

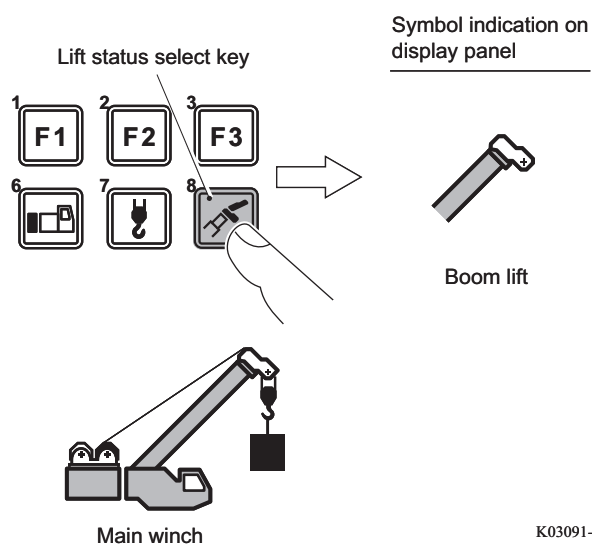

- 13.** Check that the crane automatically stops when the main hook block is overhoisted.

 If the crane does not stop automatically, refer to Step 4 and check that the wiring is connected correctly.

Now, the stowing of the single top is completed.

Jib

You can install the jib to the boom head to use it for an operation at a high place where the boom cannot reach. During traveling or for operations not requiring the jib, stow it on the side of the boom. While the jib is not used, the jib can be dismantled.

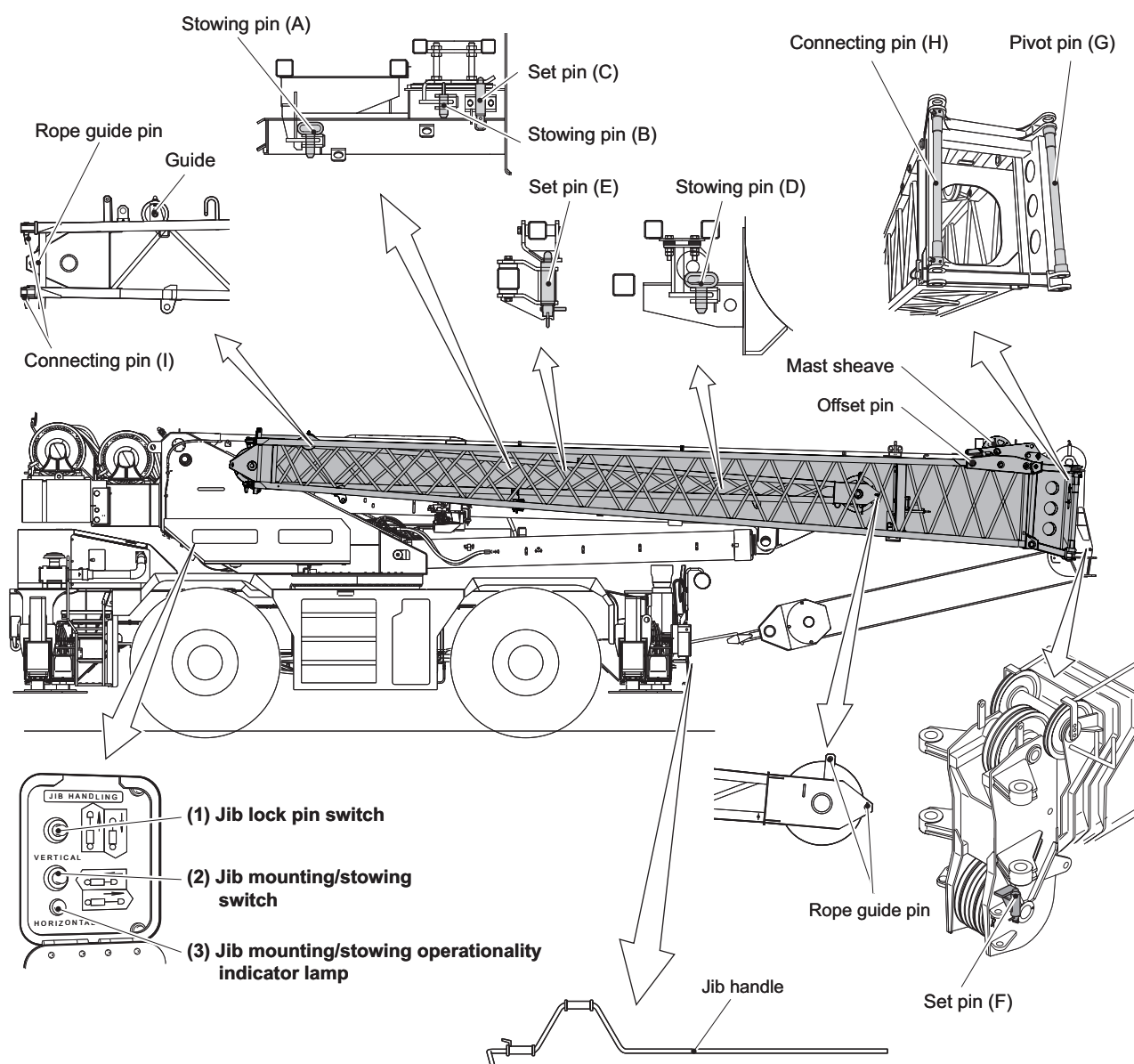

K07055-00E

(1) Jib lock pin switch

Extends/retracts the jib lock pin.

(2) Jib mounting/stowing switch

Swings out/stows the jib.

(3) Jib mounting/stowing operability indicator lamp

Lights up when the jib lock pin is retracted.

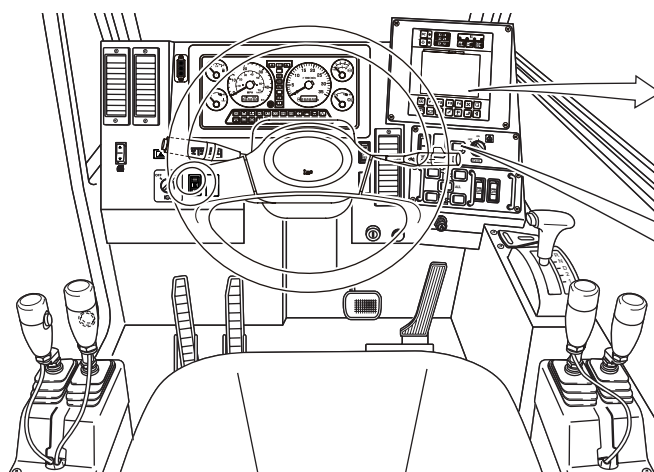

Jib lock icon

During registration of jib set state to the load moment indicator, this icon lights up when the jib mounting/stowing cylinder is extended and the jib is released from the boom. It goes out when the cylinder is fully retracted and the jib is folded to the boom.



Anti-twoblock disable switch

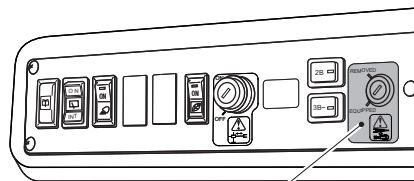
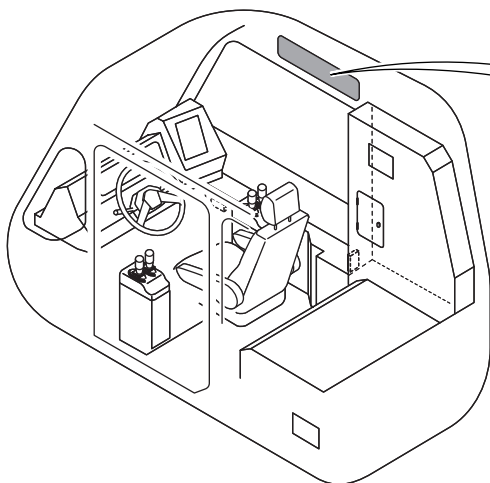

Jib status switch

This switch is used to register the state of the jib (mounted or dismounted) on the Load moment indicator.

K07039-00E

Registration of Jib State

⚠ WARNING

If the switch position does not correspond to the actual jib mounting status, the calculation base of the load moment indicator is incorrect, and the machine can overturn or be damaged.

When the jib is not required for a job, it can be dismantled from the crane.

When the jib is dismantled, the reduction of the mass affects the measurement of the load moment indicator.

You need to set the jib status switch to register the jib state.

“REMOVED”: The jib is dismantled.

“EQUIPPED”: The jib is mounted.

- When the switch is set to "REMOVED", the jib dismantlement icon appears on the display panel of the load moment indicator.

 You can insert or remove the switch key regardless of the key position.

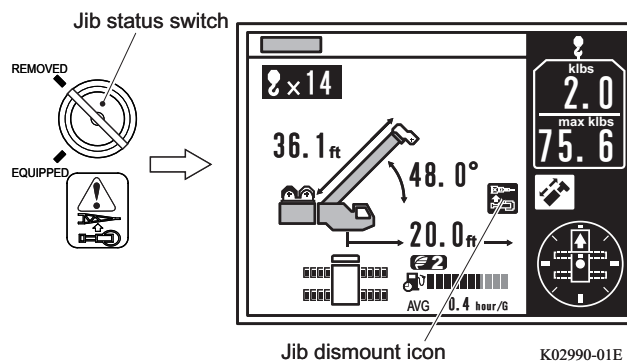

Jib Lift

⚠ WARNING

- Abrupt lever operation can cause the load to bounce or sway, resulting in an accident causing injury or death, or machine damage. Operate the levers slowly.
- Do not perform the base jib lift operation with the top jib mounted, or attached to the side of the base jib. In this state, the load moment indicator does not operate properly and the top jib is not secured completely. This can cause an accident.

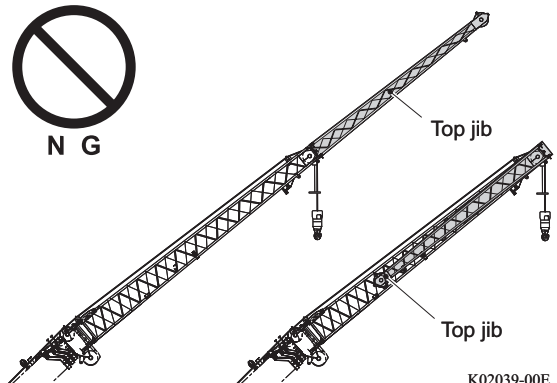

Jib Lift

You can hoist up/down a load with the jib by the main winch operation, using the main wire rope and auxiliary hook block. The operation using the auxiliary winch is also possible.

The operation speed is adjusted by the operating amount of the hoist control lever and accelerator operation.

 The boom telescoping pedal is useful for boom telescoping during the jib lift. The boom can be telescoped regardless of the position of the boom telescoping/auxiliary hoist control selector switch.

Jib Length

The available jib lengths are 33.2 ft. (10.1 m) and 58.1 ft. (17.7 m).

Jib Offset Angle

You can use the jib with three offset angles (3.5°, 25°, and 45°).

Moving in Work Site with Jib Mounted

Avoid moving in a work site with the jib mounted as much as possible. If moving in a work site in this state is necessary, set the boom and jib to the state described below, and refer to "On-rubber Creep Operation" (page 223).

- Boom length: 36.1 ft. (11 m) (fully retracted)
- Boom Angle: 0° to 40°
- Swing angle: Front (The front position symbol in a load moment indicator lights up)
- Jib Length: 33.2 ft. (10.1 m) or 58.1 ft. (17.7 m)
- Jib Offset Angle: 3.5°

If the crane condition is other than above, moving in a work site is prohibited.

Outline of Jib Installation

Outline of the jib installing operation is as follows.

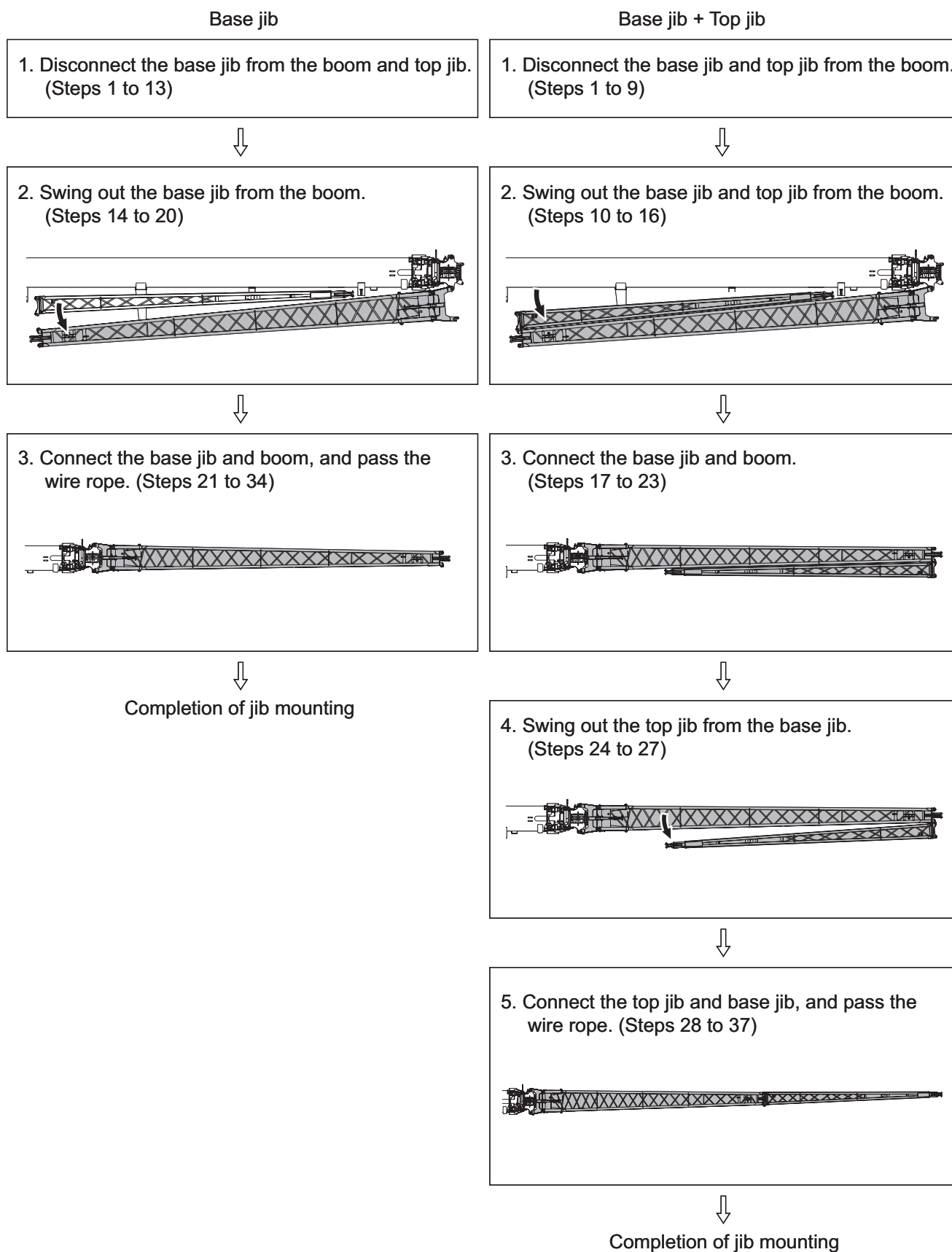

K03041-02E

Mounting of Base Jib

WARNING

- Do not enter the area under and in front of the jib during jib mounting. The jib can move unexpectedly and cause a serious injury.
- When you work on the swing frame, wear a safety belt to prevent a falling accident. Falling from the swing frame can result in a serious injury.
- Securely mount the jib. If it is not securely mounted, it can cause a serious injury.
- Do not operate the crane while the stowing pin and pivot pin are pulled out from the base jib. The jib can fall and cause a serious accident.

NOTICE

- Before mounting the jib, be sure to retract the boom fully. Otherwise, the boom can be damaged.
- If the anemometer (option) is attached to the boom head, remove it. If the jib is mounted without removing it, the machine can be damaged.

1. Fully extend the outriggers and set up the crane horizontally in a place where sufficient space is available for jib installation.
2. Take out the auxiliary hook block from the stowing position, and place it approx. 63 ft. (19m) away from the swing center.

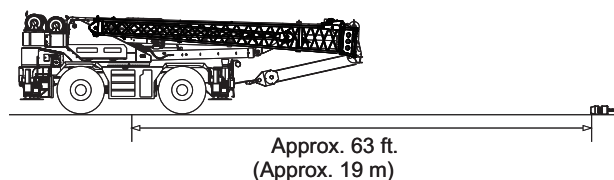

K07040-00E

3. Register the jib set state to the load moment indicator.
 - The jib state indicator symbol flashes.

NOTICE

When the jib set state is registered to the load moment indicator, the automatic stop function does not activate even if the hook block is overwound.

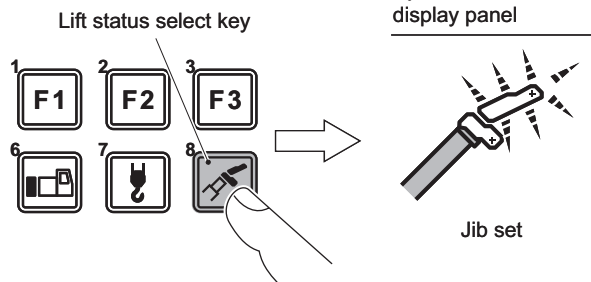

K02043-00E

4. Fully retract the boom, and set the boom angle within the range of 1.5° to 2°.

WARNING

Do not set the boom angle to 1° or less. The jib can fall and cause a serious accident.

5. Remove the main wire rope from the hook block.

 For removal of the wire rope, refer to "Reeving the Wire Ropes" (page 227).

 To perform jib lift using the auxiliary wire rope, follow the procedure below.

- (1) Remove the auxiliary wire rope from the rope arrester, and put the wire rope on the top side of the boom.

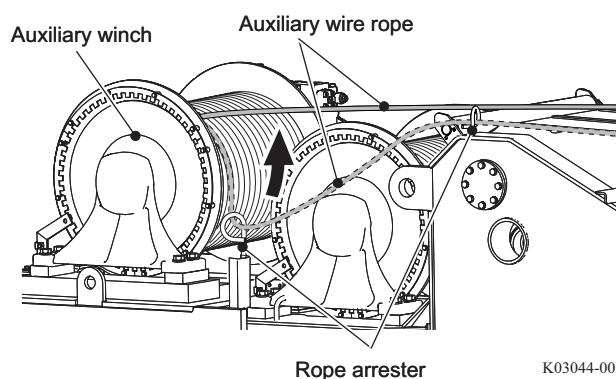

- (2) Pull out the fixing pin, and remove the rope socket for the auxiliary wire rope from the support on the jib.

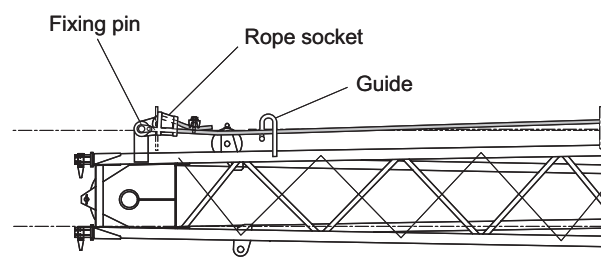

6. Hang the wire rope on the guide on the top left of the 4th boom section.

NOTICE

Be careful not to damage the cable for the boom length detector.

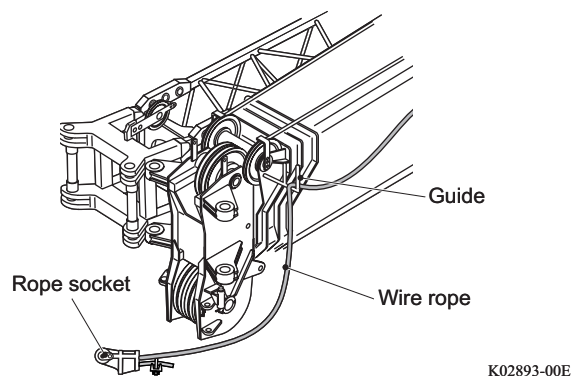

- Attach the guide rope to the top of the base jib.

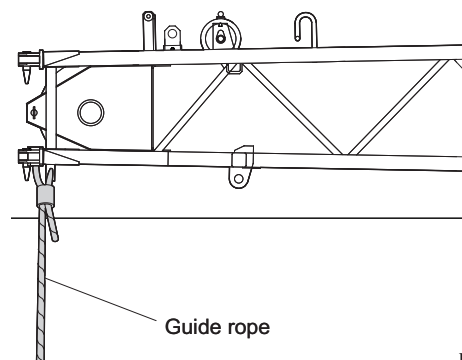

K02046-00E

- Pull out the connecting pins (I), and insert them into the stowage support. And then secure them with the snap pins.

The connecting pin (I) connects the base jib and top jib.

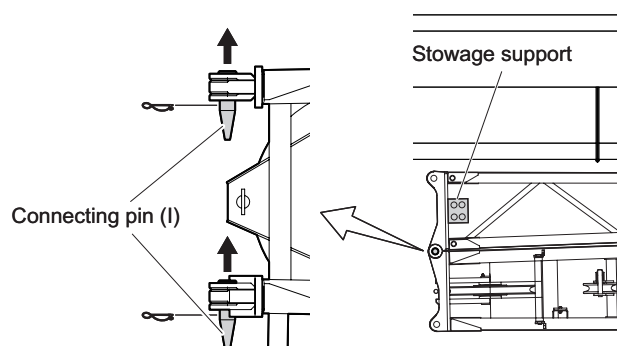

K02047-00E

- Pull out the stowing pin (A) and set pin (E). Insert the stowing pin (A) to the stowing position, and secure it with the snap pin. Rotate the set pin (E) and hitch it on the guide.

⚠ WARNING
 Do not operate the crane with the connecting pin (I), stowing pin (A), or set pin (E) pulled out. The jib can fall and cause a serious accident.

The stowing pin (A) connects the jib and boom.

The set pin (E) connects the base jib and top jib.

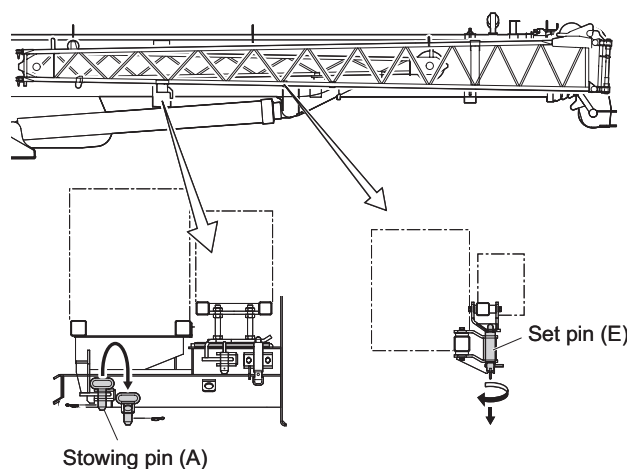

K02048-00E

- Swing the top end of the base jib in the direction away from the boom.

The jib swings about the center support.

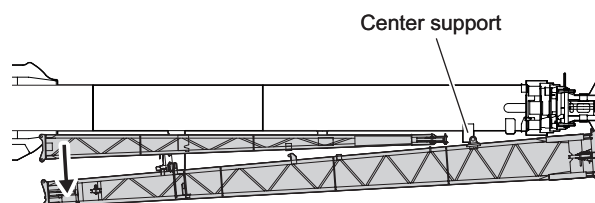

K02049-00E

- 11.** Check that the set pin for the jib mounting/stowing cylinder on the stowage support is inserted into the pin hole on the base jib.

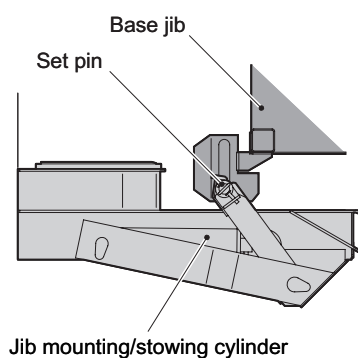

K02050-00E

- 12.** Check that the pivot pin (G) is aligned with the pin hole on the base jib, and insert the pivot pin (G) using the jib handle.

NOTICE

Do not extend the boom while the jib is supported by the two points of the pivot pin and center support. Otherwise, the jib will be damaged.

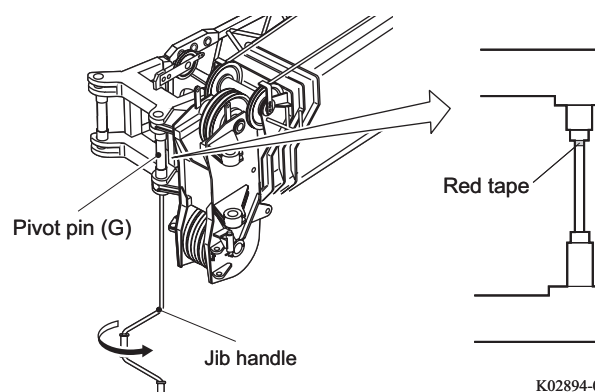

K02894-00E

-  Insert the pivot pin (G) securely until the red tape on the thread appear. When the insertion of the pivot pin (G) is completed, the jib lock pin on the center support can be retracted.

- 13.** Using the jib handle, remove the set pin (F) from the guide to make the pin free.

-  When swung, the jib is locked by the set pin (F).

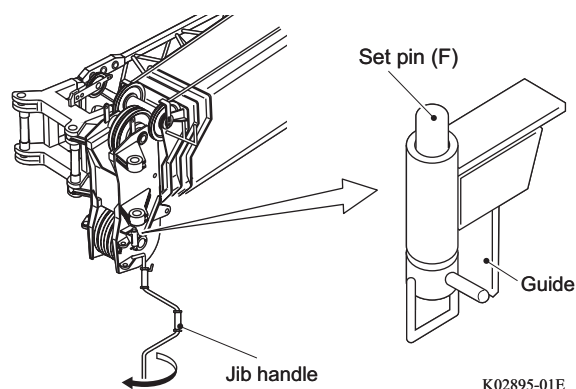

K02895-01E

14. Set the jib lock pin switch to the "retract" side, and retract the jib lock pin.

- The jib is released from the center support.
- When the retraction of the jib lock pin is completed, the jib mounting/stowing operability indicator lamp lights up.

 Full retraction of the jib lock pin is required to operate the jib mounting/stowing cylinder.

 When the jib set state is not registered to the load moment indicator, the jib lock pin switch does not work.

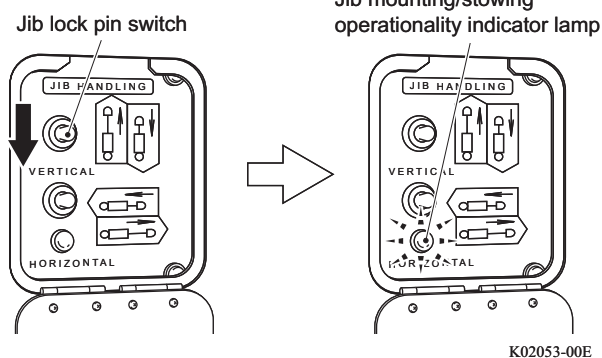

15. Set the jib mounting/stowing switch to the "mounting" side, and swing out the jib outward.

- When the jib mounting/stowing cylinder is extended and the jib is released from the boom, the jib lock icon highlights on the load moment indicator.

 Fully extend the jib mounting/stowing cylinder.

 When the jib set state is not registered to the load moment indicator, the jib mounting/stowing switch does not work.

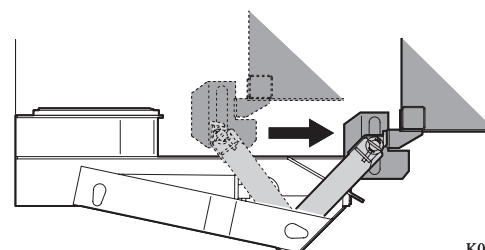
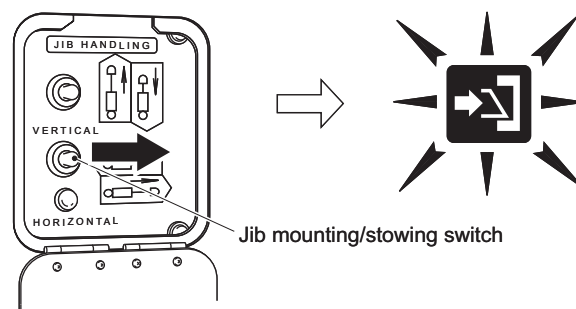

16. Pull out the set pin of the stowage support, and hitch it to the guide.

- The jib is released from the stowage support.

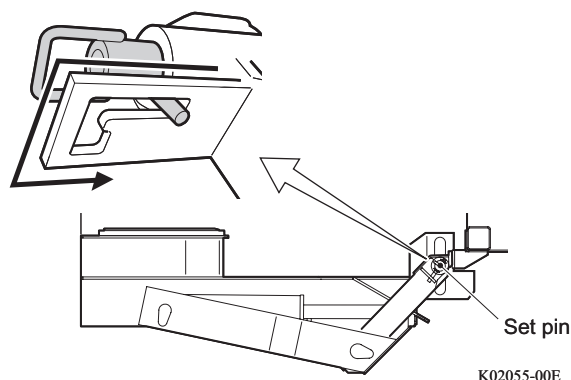

17. Pull the guide rope to swing the jib forward until it is locked by the set pin (F).

WARNING

Do not enter the area where the jib swings or under the jib. The jib can move unexpectedly and cause an injury.

NOTICE

Before swinging the jib, be sure to retract the boom fully. Otherwise, the boom can be damaged.

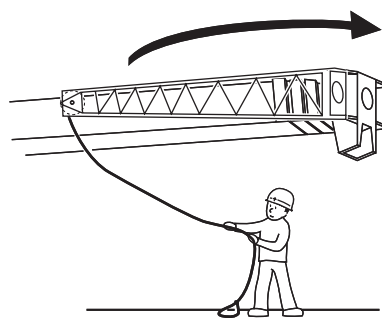

K02057-000

18. Check that the connecting pin (H) is aligned with the pin hole on the lower side of the base jib, and insert the connecting pin (H) using the jib handle.

 The connecting pin (H) is inserted into the pin hole on the lower side of the base jib.

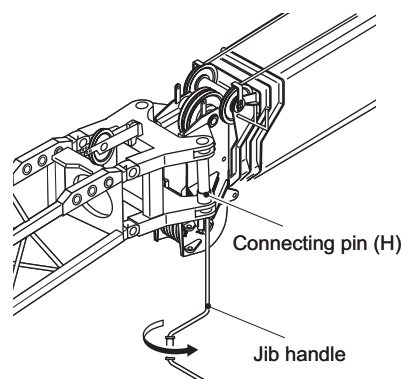

K02429-00E

19. Set the jib mounting/stowing switch to the "stowing" side to return the jib mounting/stowing cylinder to the stowing position.

NOTICE

If the jib mounting/stowing cylinder is left extended, it may obstruct the crane operation and damage the cylinder.

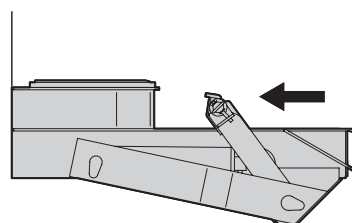

K02056-000

20. Set the boom horizontally, and remove the guide rope from the base jib.

- 21.** Raise the mast sheave on the upper surface of the base jib, and insert the fixing pin and secure it with the snap pin.

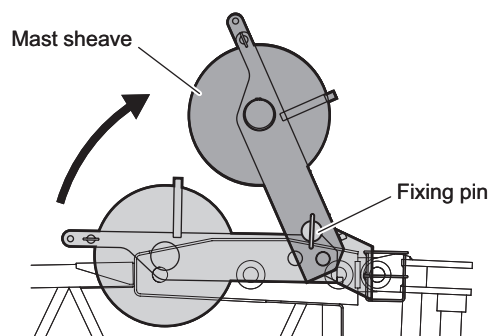

K02430-00E

- 22.** Reeve the wire rope through the sheaves on the upper surface of the base boom section and upper surface of the jib.

NOTICE

Do not reeve the wire rope from the winch used for the jib lift through the sheave on the top boom section. The rope guide pin can be damaged.

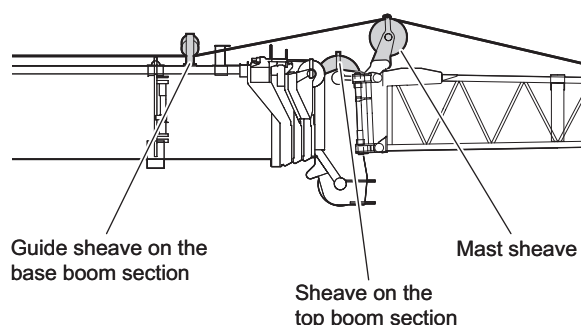

K02060-00E

- 23.** Mount the rope socket to the bracket on the base jib with the fixing pin.

NOTICE

Mount the rope socket always as shown in the illustration. If mounted upside down, the rope socket contacts the lower surface of the jib and can be damaged during hoisting operation.

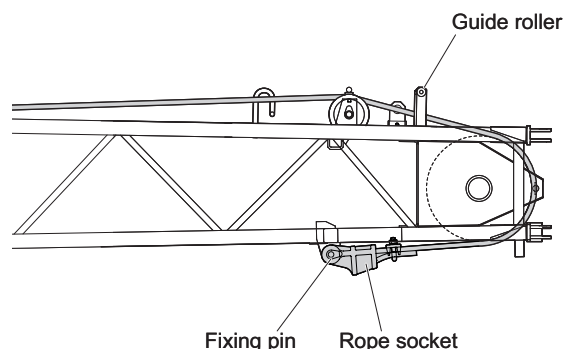

K02584-00E

 Pass the wire rope under the guide roller.

- 24.** Wind up the wire rope slowly, and align the connecting pin (H) with the pin hole on the upper side of the top boom section.

NOTICE

Do not extend or lower the boom. Such operations can cause damage to the jib.

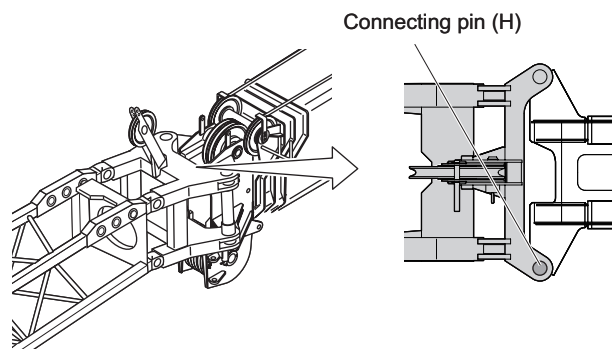

K02896-01E

- 25.** Check that the connecting pin (H) is aligned with pin hole on the upper side of the base jib, and insert the connecting pin (H) using the jib handle.

 Insert the connecting pin (H) securely until the red tape on the thread appears.

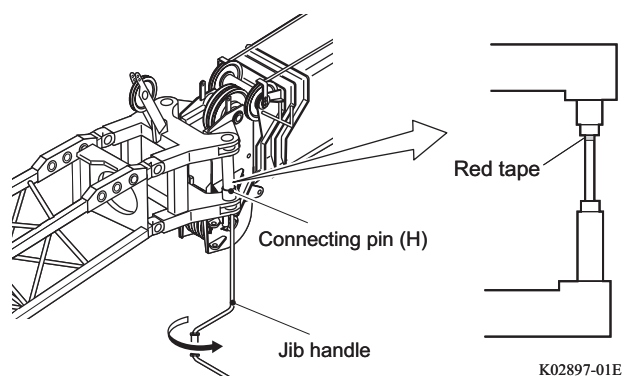

- 26.** Wind down the wire rope to loosen it slightly.

- 27.** Remove the rope socket from the bracket on the jib.

- 28.** Mount the twoblocking detection switch to the top of the base jib.

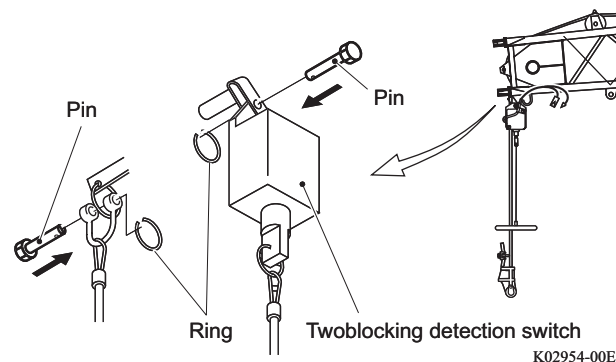

- 29.** Connect the wiring for the anti-two block device as shown in the illustration.

NOTICE

To disconnect the wiring, pull the connector itself and never pull on the cord.
The cord can be broken.

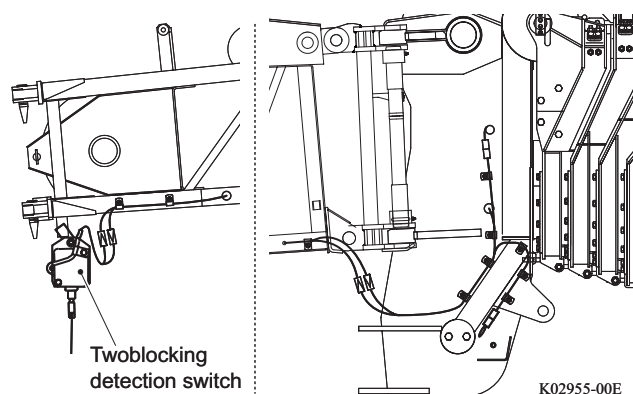

30. Stow the weight to the support on the boom head, and insert the pin through the rod of the twoblocking detection switch, in order that the anti-two block device for boom lift does not activate.

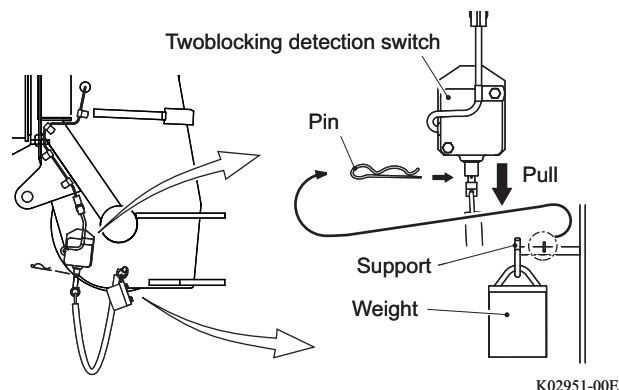

K02951-00E

31. Wind down and reel out the wire rope.

To prevent a disorderly rope winding, pull the wire rope by hand while winding down.

32. Attach the rope socket to the auxiliary hook block.

⚠ WARNING

Securely tighten the fixing pin mounting bolt for the rope socket using a wrench. After the fixing pin is attached, secure it using a split pin so that the fixing pin does not come out. Improper installation can cause the rope socket to come off and the lifted load to fall, resulting an accident.

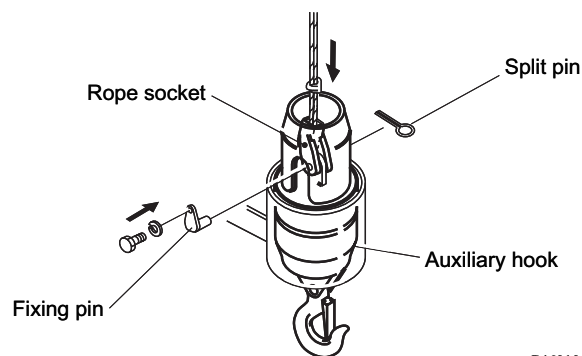

G46010-00E

33. Register the lift state (main winch use, 33.2 ft. (10.1 m) jib, 3.5° offset operation) to the load moment indicator.

To use the auxiliary winch, refer to "Selection of winch to be used" (page 177), and change the load moment indicator setting.

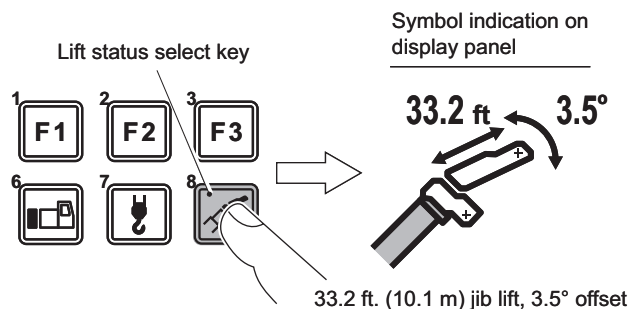

33.2 ft. (10.1 m) jib lift, 3.5° offset

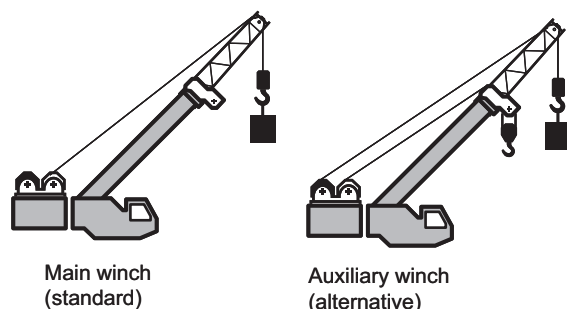

K02956-01E

34. Check that the crane automatically stops when the auxiliary hook block is overhoisted.

 If the crane does not stop automatically, refer to Step 29 and check that the wiring is connected correctly.

Now, the mounting of the base jib is completed.

Mounting of Base Jib + Top Jib

⚠ WARNING

For basic precautions, refer to the previous section "Mounting of Base Jib."
Observe the precautions in the section "Mounting of Base Jib" during operation.

NOTICE

- Be sure to mount the base jib before mounting the top jib.
Incorrect mounting practice can damage the boom.
Mount the jib according to the set procedure.
- If the anemometer (option) is attached to the boom head, remove it.
If the jib is mounted without removing it, the machine can be damaged.

1. Fully extend the outriggers and set up the crane horizontally in a place where sufficient space is available for jib installation.
2. Take out the auxiliary hook block from the stowing position, and place it approx. 88 ft. (27m) away from the swing center.
3. After completing the Steps 3 to 7 of the chapter "Mounting of Base Jib", attach a guide rope to the top of the base jib.

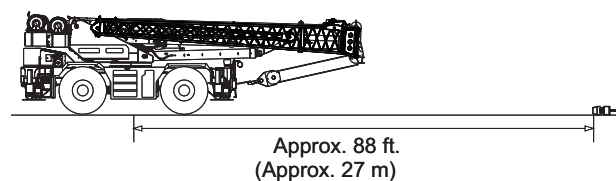

K07041-00E

4. Check that the base jib and top jib are connected by the connecting pins (I) and secured with snap pins.

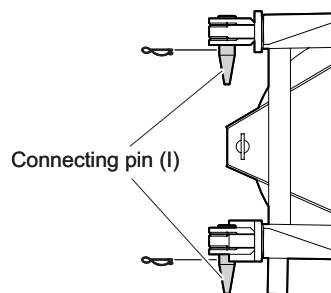

K02069-00E

⚠ WARNING

Do not pull out the stowing pins (B) and (D) when the connecting pins (I) are not inserted. The top jib may fall.

(A), (B), (D): Stowing pin

(C), (E): Set pin

(I): Connecting pin

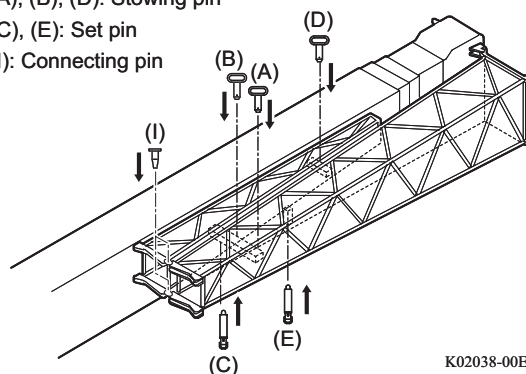

K02038-00E

5. Pull out the stowing pins (A), (B), (D) and the set pin (C). Insert the stowing pins (A), (B), and (D) to the stowing position and secure them with the snap pins.

Rotate the set pin (C), and hitch it on the guide.

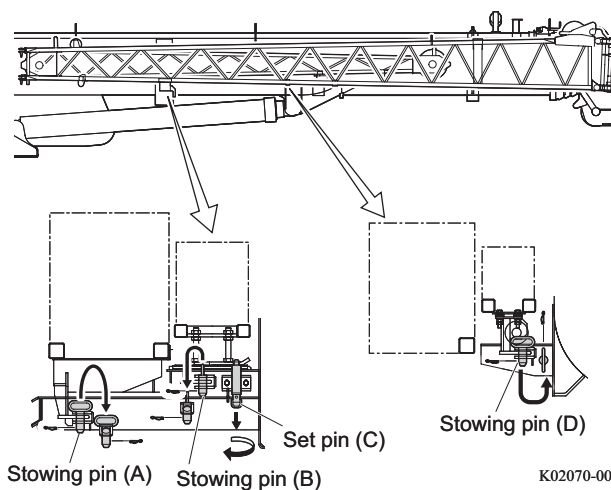

K02070-00E

⚠ WARNING

Do not operate the crane with the stowing pins (A), (B), (D) and the set pin (C) pulled out. The jib can fall and it can cause a serious accident.

☞ The stowing pins (A), (B) and the set pin (C) connect the jib and boom.

☞ The stowing pin (D) connects the top jib and boom.

6. Swing the top of the base jib away from the boom.

 The jib swings about the center support.

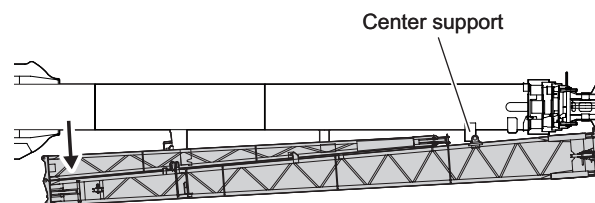

K02071-00E

7. Check that the set pin for the jib mounting/stowing cylinder on the stowage support is inserted into the pin hole on the base jib.

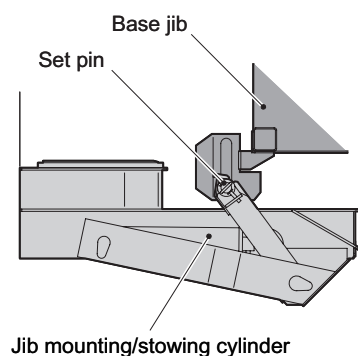

K02050-00E

8. Check that the pivot pin (G) is aligned with the pin hole on the base jib, and insert the pivot pin (G) using the jib handle.

NOTICE
Do not extend the boom while the jib is supported by the two points of the pivot pin and center support. Otherwise, the jib will be damaged.

 Insert the pivot pin (G) securely until the red tape on the thread appears. When the insertion of the pivot pin (G) is completed, the jib lock pin on the center support can be retracted.

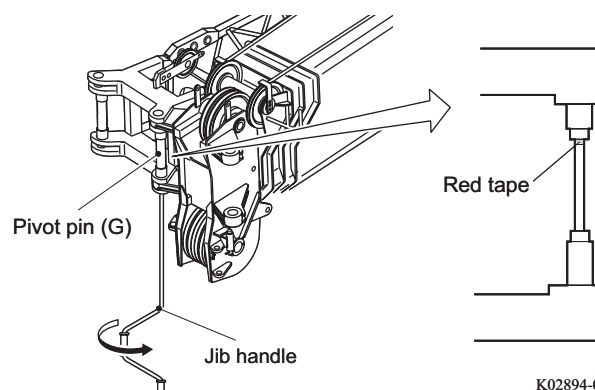

K02894-00E

- 9.** Using the jib handle, remove the set pin (F) from the guide to make the pin free.

 When swung, the jib is locked by the set pin (F).

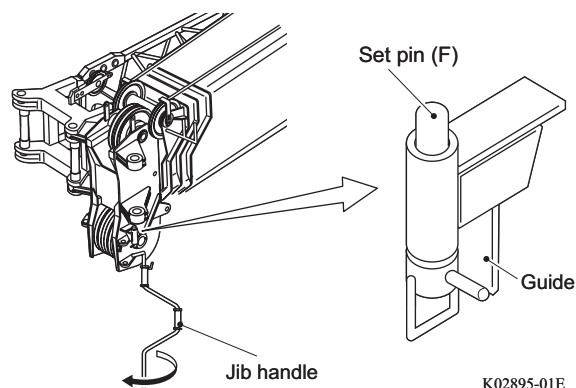

- 10.** Set the jib lock pin switch to the "retract" side to retract the jib lock pin.

- The jib is released from the center support.
- When the retraction of the jib lock pin is completed, the jib mounting/stowing operability indicator lamp lights up.

 Full retraction of the jib lock pin is required to operate the jib mounting/stowing cylinder.

 When the jib set state is not registered to the load moment indicator, the jib lock pin switch does not work.

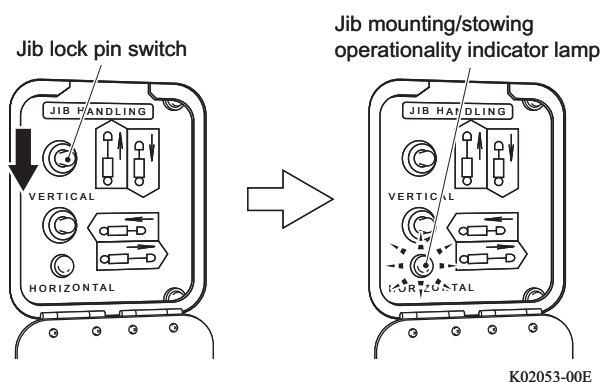

- 11.** Set the jib mounting/stowing switch to the "mounting" side, and swing out the jib outward.

- When the jib mounting/stowing cylinder is extended and the jib is released from the boom, the jib lock icon highlights on the load moment indicator.

 Fully extend the jib mounting/stowing cylinder.

 When the jib set state is not registered to the load moment indicator, the jib mounting/stowing switch does not work.

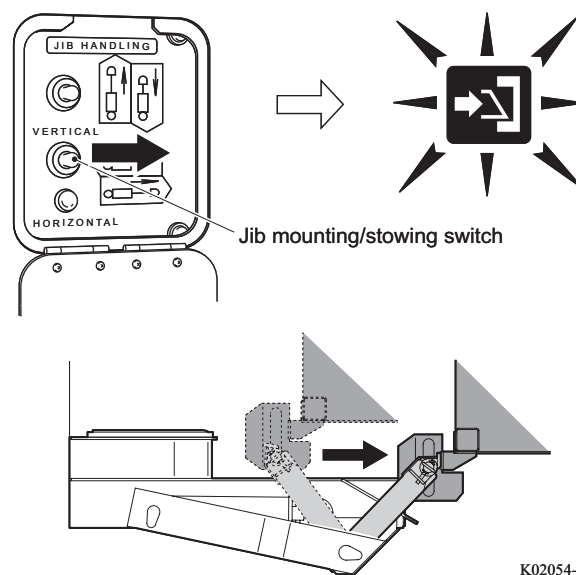

- 12.** Pull out the set pin on the stowage support, and hitch it to the guide.

- The jib is released from the stowage support.

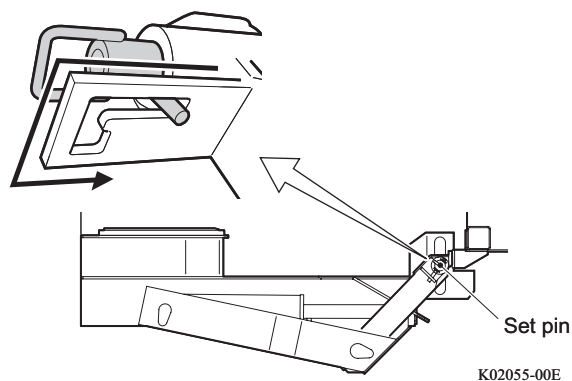

- 13.** Pull the guide rope and swing the jib forward until it is locked by the set pin (F).

⚠ WARNING

Do not enter the area where the jib swings or under the jib. The jib can move unexpectedly and cause an injury.

NOTICE

Before swinging the jib, be sure to retract the boom fully. Otherwise, the boom can be damaged.

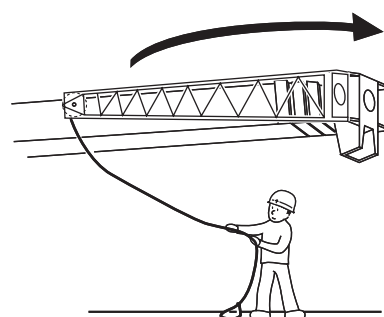

- 14.** Check that the connecting pin (H) is aligned with the pin hole on the lower side of the base jib, and insert the connecting pin (H) using the jib handle.

- ☞ The connecting pin (H) is inserted into the pin hole on the lower side of the base jib.

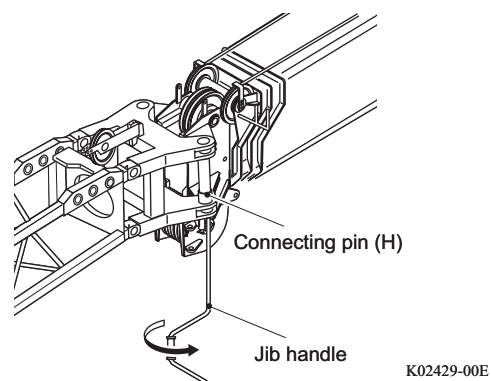

- 15.** Set the jib mounting/stowing switch to the "stowing" side to return the jib mounting/stowing cylinder to the stowing position.

NOTICE

If the jib mounting/stowing cylinder is left extended, it can obstruct the crane operation and damage the cylinder.

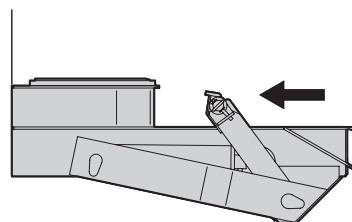

K02056-000

- 16.** Set the boom horizontally, and remove the guide rope from the base jib.

- 17.** Raise the mast sheave on the upper surface of the base jib, and insert the fixing pin and secure it with the snap pin.

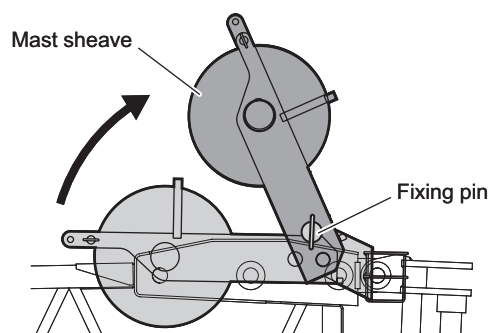

K02430-00E

- 18.** Reeve the wire rope through the sheaves on the upper surface of the base boom section and upper surface of the jib.

NOTICE

Do not reeve the wire rope from the winch used for the jib lift through the sheave on the top boom section. The rope guide pin can be damaged.

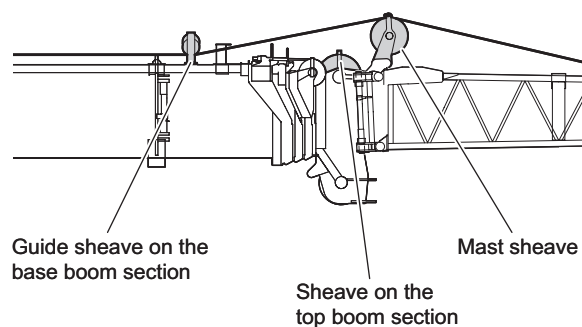

K02060-00E

19. Mount the rope socket to the bracket on the base jib with the fixing pin.

NOTICE

Mount the rope socket always as shown in the figure. If mounted upside down, the rope socket contacts the lower surface of the jib and can be damaged during the hoisting operation.

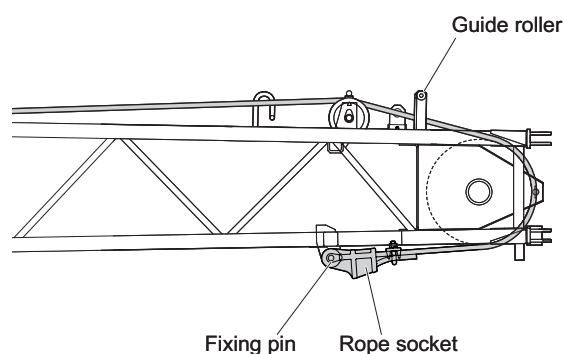

K02584-00E

☞ Pass the wire rope under the guide roller.

20. Wind up the wire rope slowly, and align the connecting pin (H) with the pin hole on the upper side of the top boom.

NOTICE

Do not extend or lower the boom. Such operations can cause damage to the jib.

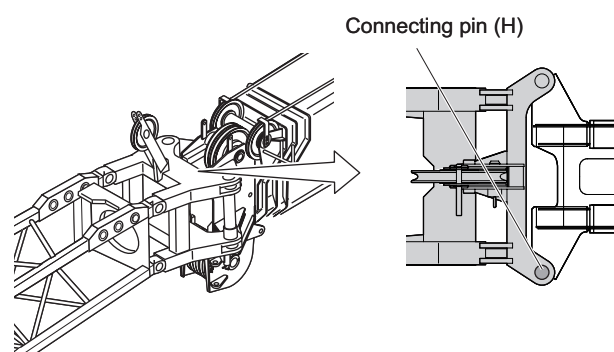

K02896-01E

21. Check that the connecting pin (H) is aligned with the pin hole on the upper side of the base jib, and insert the connecting pin (H) using the jib handle.

☞ Insert the connecting pin (H) securely until the red tape on the thread appears.

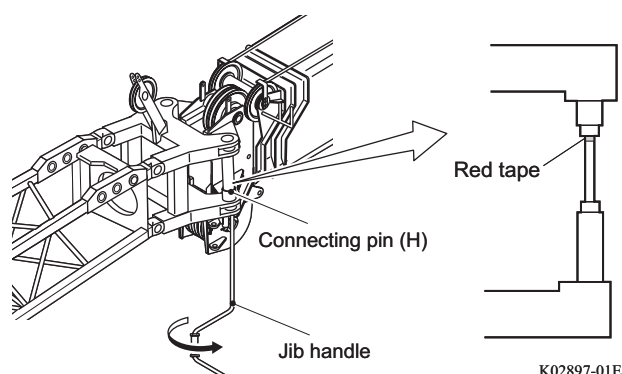

K02897-01E

22. Wind down the wire rope to loosen it slightly.
23. Remove the rope socket from the bracket on the base jib.

- 24.** Attach the guide rope to the top of the top jib.

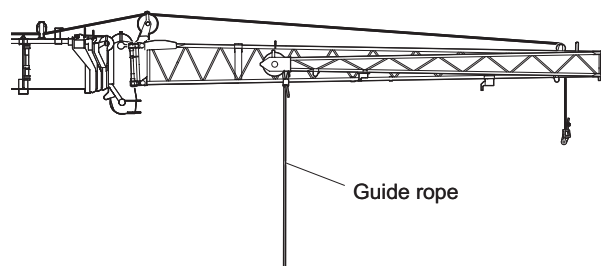

K02072-00E

- 25.** Raise the boom until the boom angle becomes 3° (jib angle -0.5°).

- 26.** While holding the guide rope, pull out the set pin (E), and hitch it to the guide.

⚠ WARNING

Check that the boom angle is 3° or more before pulling out the set pin (E). If the set pin is pulled out while the jib inclination is steep, the jib can swing forward faster than expected, causing an accident.

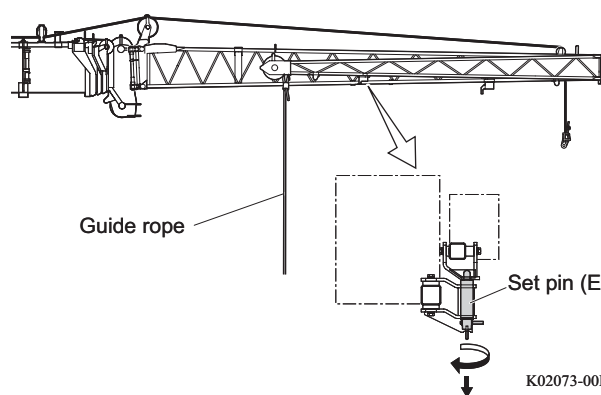

K02073-00E

- 27.** Pull the guide rope to swing the top jib forward.

⚠ WARNING

Do not enter the area where the jib swings or under the jib. The jib can move unexpectedly and cause an injury.

NOTICE

Before swinging the jib, be sure to retract the boom fully. Otherwise, the boom can be damaged.

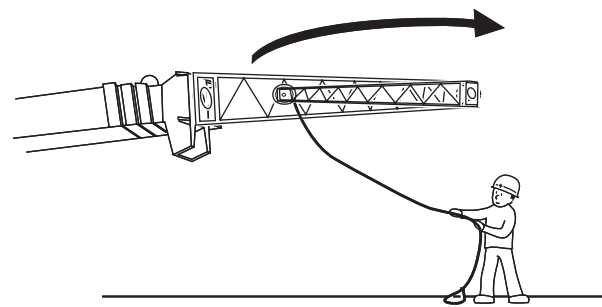

K02074-000

- 28.** Lower the boom, and insert the connecting pins (I). Then secure them with the snap pins.

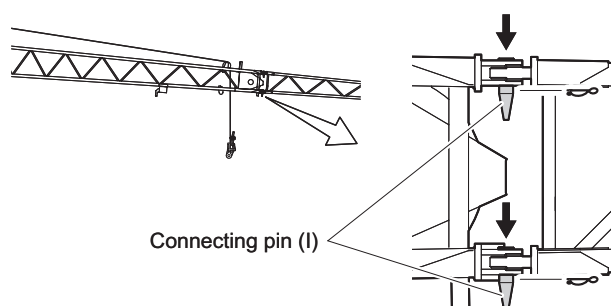

K02075-00E

29. Wind down and reel out the wire rope to the top end of the top jib, and reeve it through the sheave.

- ☞ Do not reeve the wire rope through the guide sheave on the top of the base jib.
- ☞ To prevent a disorderly rope winding, pull the wire rope by hand while winding down.

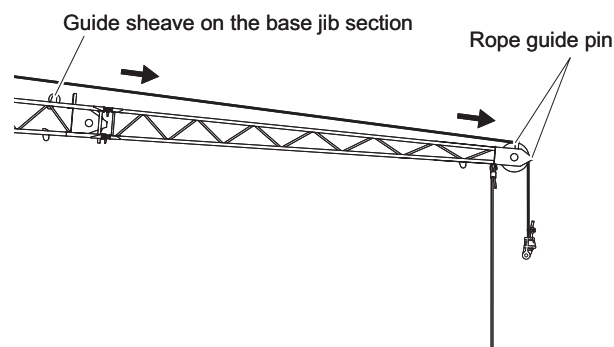

K02076-000

30. Remove the guide rope.

31. Mount the twoblocking detection switch to the top end of the top jib.

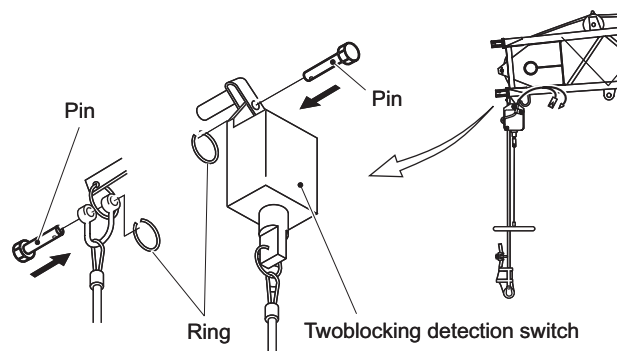

K02954-00E

32. Connect the wiring for the anti-twoblock device as shown in the illustration.

NOTICE

To disconnect the wiring, pull the connector itself, and never pull on the cord. The cord can be broken.

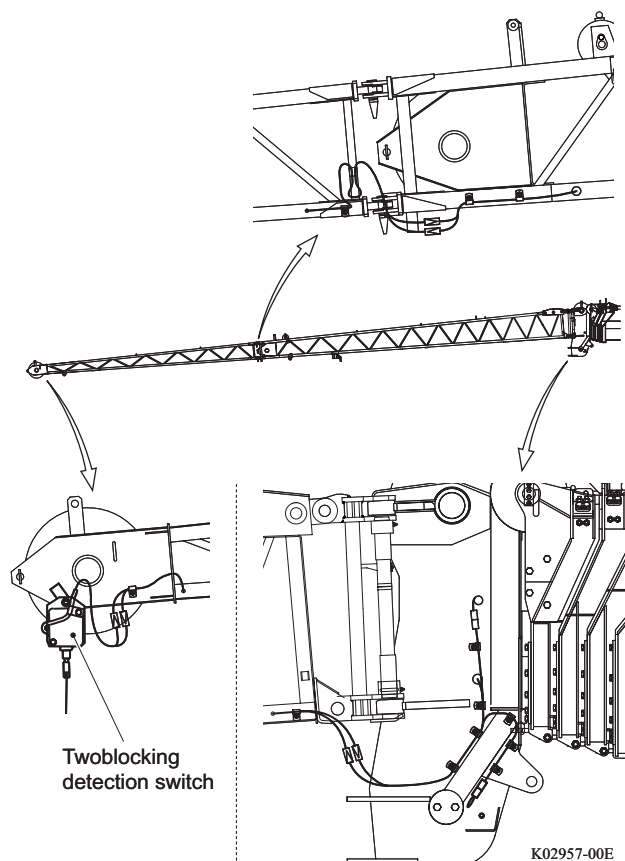

K02957-00E

33. Stow the weight to the support on the boom head and insert the pin through the rod of the twoblocking detection switch, in order that the anti-twoblock device for boom lift does not activate.

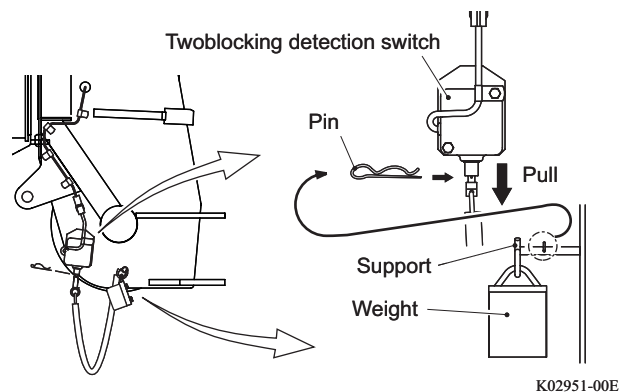

34. Wind down and reel out the wire rope.

To prevent a disorderly rope winding, pull the wire rope by hand while winding down.

35. Install the rope socket to the auxiliary hook block.

⚠ WARNING

Securely tighten the fixing pin mounting bolt for the rope socket using a wrench. After attaching the fixing pin, secure it using a split pin so that the fixing pin does not come out. Improper installation can cause the rope socket to come off and the lifted load to fall, resulting an accident.

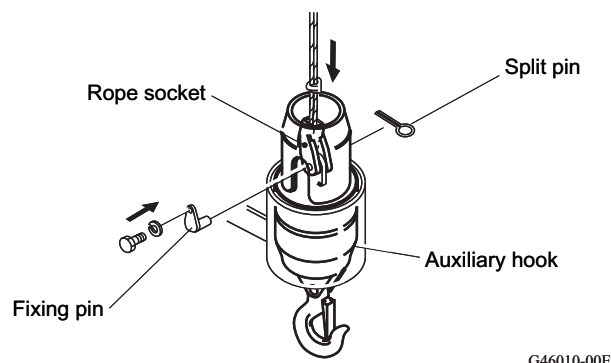

36. Register the lift state (main winch use, 58.1 ft. (17.7 m) jib, 3.5° offset operation) to the load moment indicator.

To use the auxiliary winch, refer to "Selection of winch to be used" (page 177), and change the load moment indicator setting.

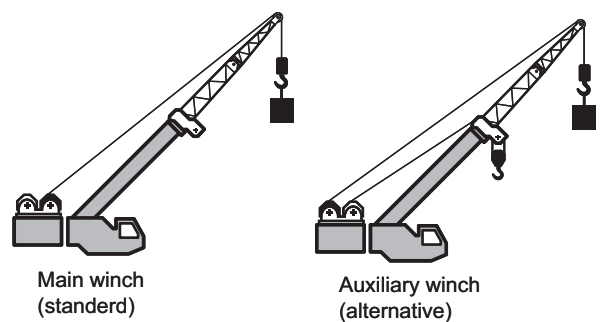
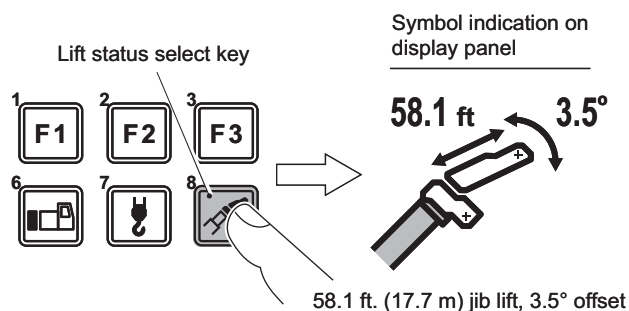

37. Check that the crane automatically stops when the auxiliary hook block is overhoisted.

 If the crane does not stop automatically, refer to Step 32 and check that the wiring is connected correctly.

Now, the mounting of the base jib and top job is completed.

Changing Jib Offset Angle

WARNING

- Do not enter the area under the jib while changing the jib offset angle. Unexpected movement of the jib can cause a serious injury.
- When you work at an elevated place, use a platform to prevent a falling accident. Falling from an elevated place can result in a serious injury.

NOTICE

- Be sure to change the jib offset angle with the boom fully retracted.
- If the offset angle is changed while the boom is extended, the boom can be damaged.
- When the jib offset angle is increased, the load radius increases as well. When you increase the offset angle, pay attention so that an overload does not occur.

1. Fully retract the boom, and lower the boom so that the top end of the jib comes near the ground.
2. Register the jib set state to the load moment indicator.
 - The jib state indicator symbol flashes.

NOTICE

When the jib set state is registered to the load moment indicator, the automatic stop function does not activate even if the hook block is overwound.

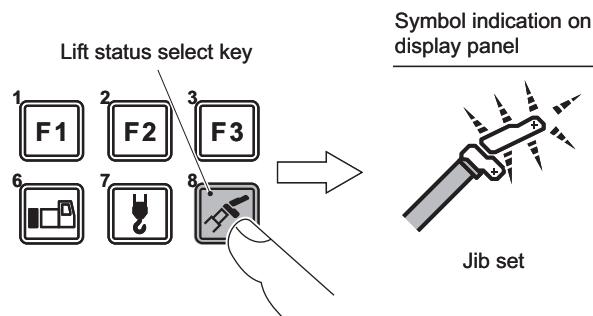

K02043-00E

3. Remove the auxiliary hook block, and mount the rope socket to the support on the jib with the fixing pin.

NOTICE

Mount the rope socket always as shown in the illustration. If mounted upside down, the rope socket contacts the lower surface of the jib and can be damaged when the wire rope is tensioned.

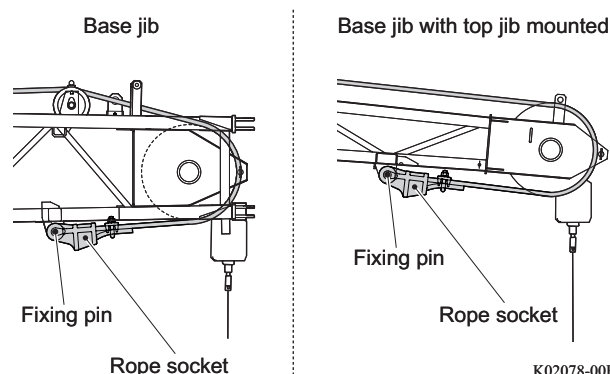

K02078-00E

4. Wind up the wire rope until the stopper touches the boss.

⚠ WARNING

**Do not lower the boom while the stopper is in contact with the boss.
The jib and wire rope can be damaged, causing a serious accident.**

☞ Lower the boom at the same time so that the top end of the jib comes close to the ground.

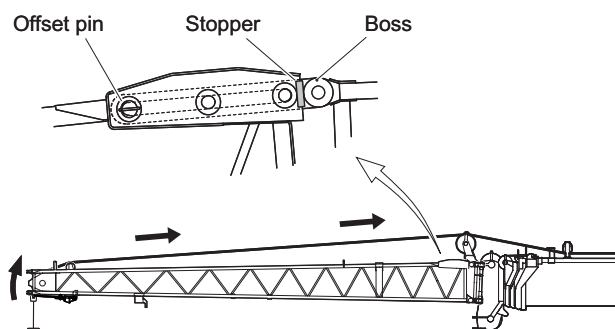

K02079-00E

5. Insert the offset pins to the holes for the desired angle.

⚠ WARNING

**Be sure to secure the offset pins using the provided snap pins.
If the offset pins comes off, it can cause damage to the jib or an accident.**

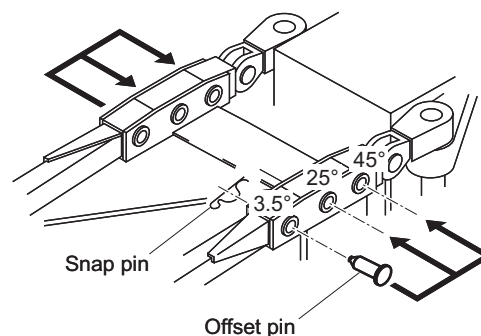

K02401-00E

6. Wind down the winch slowly until the jib is retained by the offset pin and the wire rope loosens slightly.

☞ Raise the boom at the same time so that the top of the jib does not touch the ground.

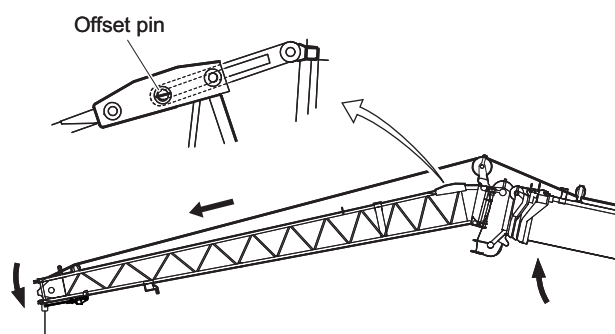

K02081-00E

7. Wind down the wire rope to loosen it slightly.
8. Remove the rope socket from the support on the jib.

- Pass the rope socket through the weight for the anti-twoblock device, and then mount it to the auxiliary hook block.

⚠ WARNING
 Securely tighten the fixing pin mounting bolt for the rope socket using a wrench. After attaching the fixing pin, secure it using a split pin so that the fixing pin does not come out. Improper installation can cause the rope socket to come off and the lifted load to fall, resulting an accident.

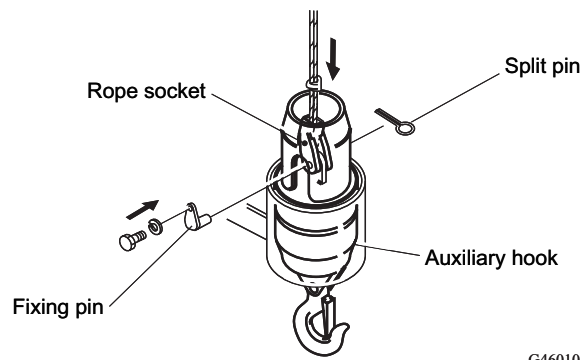

G46010-00E

- Register the lift state to the load moment indicator.

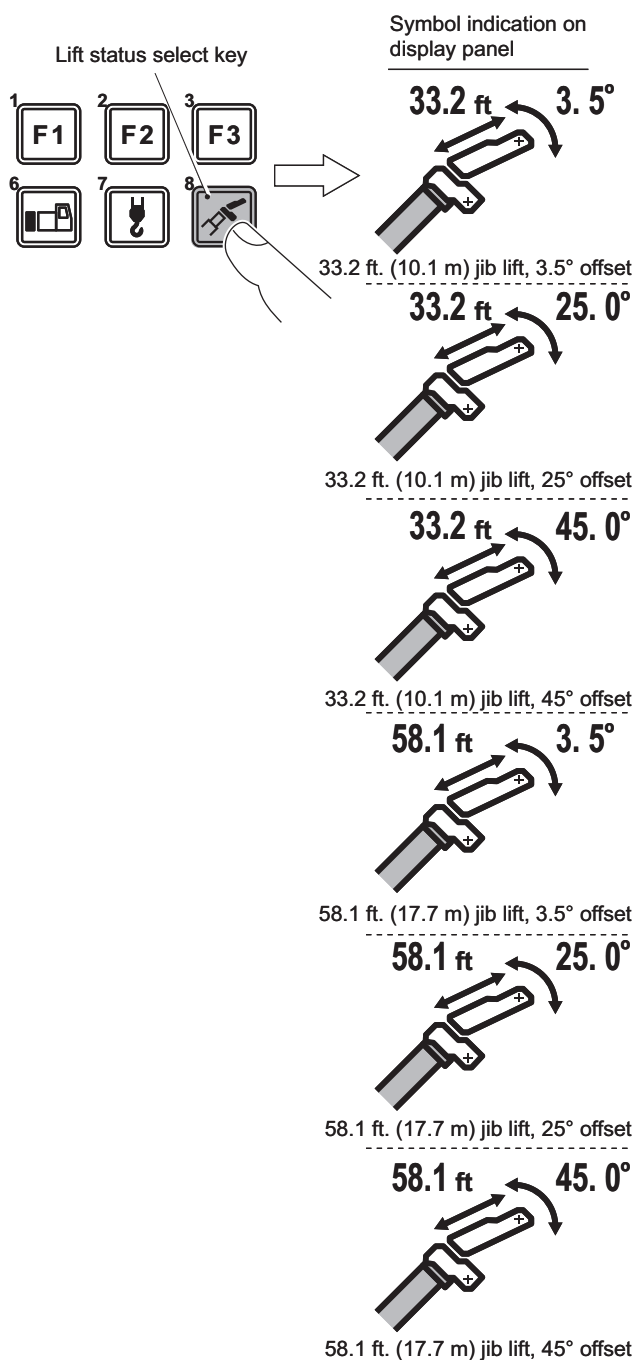

K02959-01E

Now, the change of the jib offset angle is completed.

Outline of Jib Stowing

Outline of jib stowing operation is as follows.

Base jib

1. Disconnect the base jib from the boom.
(Steps 1 to 12)



2. Swing the base jib to the stowing side.
(Steps 13 to 16)

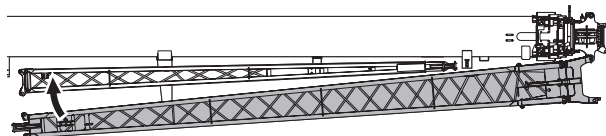

3. Connect the base jib to the boom and top jib.
(Steps 17 to 25)

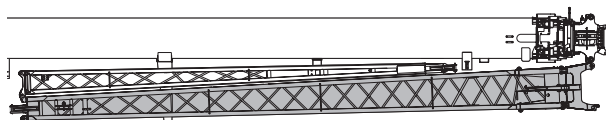

Completion of jib stowing

Base jib + Top jib

1. Disconnect the top jib from the base jib.
(Steps 1 to 8)



2. Swing the top jib to the stowing side, and connect the base jib and top jib.
(Steps 9 to 11)

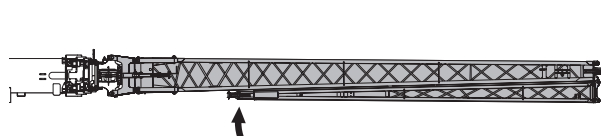

3. Disconnect the base jib from the boom.
(Steps 12 to 15)



4. Swing the base jib and top jib to the stowing side.
(Steps 16 to 17)

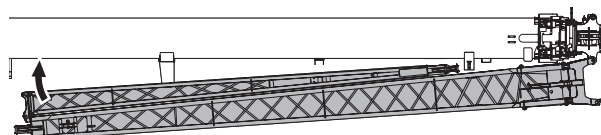

5. Connect the base jib and top jib to the boom.
(Steps 18 to 21)

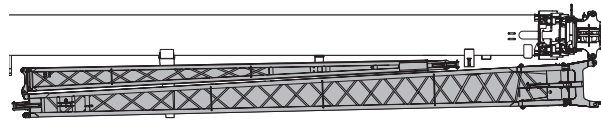

Completion of jib stowing

K03065-01E

Stowing of Base Jib

WARNING

- Do not enter the area under and in front of the jib during jib stowing. The jib can move unexpectedly and cause a serious injury.
- When you work on the swing frame, wear a safety belt to prevent a falling accident. Falling from the swing frame can result in a serious injury.
- After the completion of stowing jib, make sure that the jib is secured with the stowing pins, set pins, and connecting pins. If the jib is not secured, it can fall during the boom lift or traveling, causing a serious accident.

(A), (B), (D): Stowing pin
(C), (E): Set pin
(I): Connecting pin

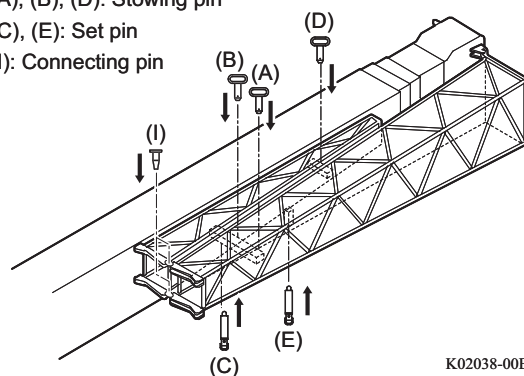

K02038-00E

NOTICE

- Before stowing the jib, be sure to retract the boom fully. Otherwise, the boom can be damaged.
- If the anemometer (option) is attached to the jib head, remove it. If jib stowing operation is performed with the option mounted, it can damage the machine.

1. Set the machine into the following state.
 - Boom length: fully retracted
 - Boom Angle: horizontal
 - Jib Offset Angle: 3.5°
2. Remove the set pin (E) from the guide to make it free.

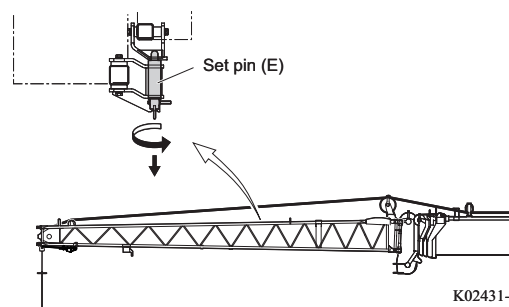

K02431-00E

3. Register the jib set state to the load moment indicator.

NOTICE

When the jib set state is registered to the load moment indicator, the automatic stop function does not activate even if the hook block is overwound.

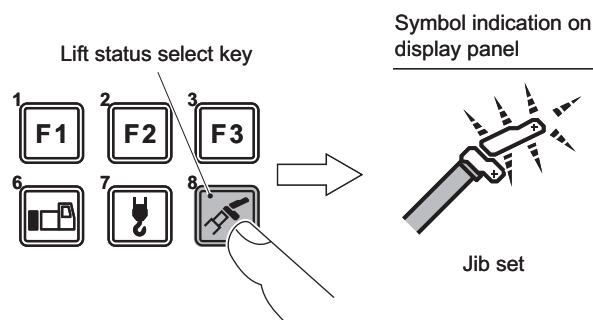

K02043-00E

4. Connect the wire for the twoblocking detection switch as shown in the illustration.

NOTICE

To disconnect the wiring, pull the connector itself, and never pull on the cord. The cord can be broken.

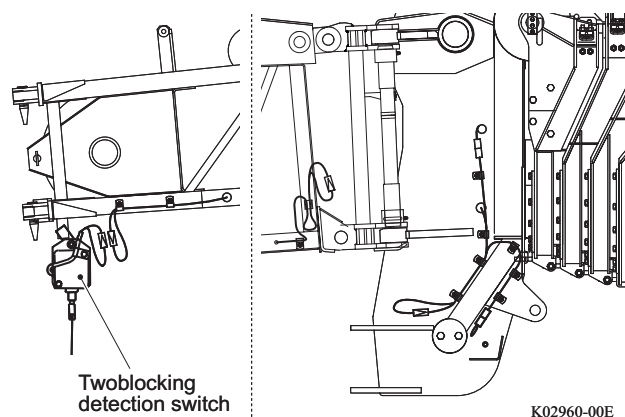

5. Remove the weight from the support on the boom head and remove the pin from the rod for the twoblocking detection switch so that the anti-twoblock device for boom lift can be activated. Stow the removed pin on the support.

WARNING

If you do not pull out the pin inserted in the rod for the twoblocking detection switch, the anti-twoblock device for the main winch does not function during the boom lift. It can cause the hook block to collide with the boom and a lifted load to fall down, resulting in a serious accident. Before the boom lift, make sure that the anti-twoblock device functions properly.

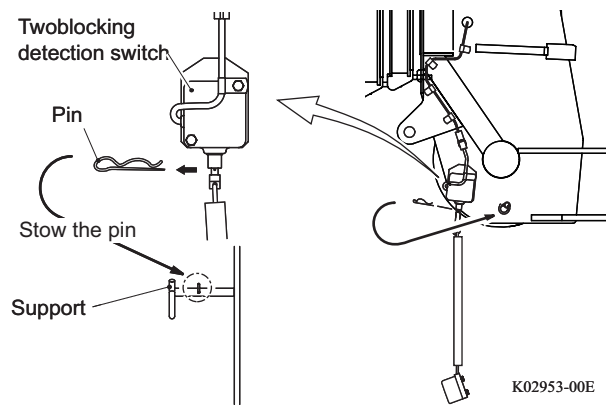

6. Remove the rope socket from the auxiliary hook block, and mount it to the bracket on the base jib with the fixing pin.

NOTICE

Mount the rope socket always as shown in the illustration. If mounted upside down, the rope socket contacts the lower surface of the jib and can be damaged during the hoisting operation.

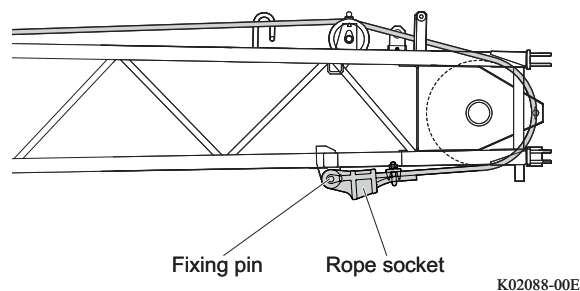

7. Wind up the wire rope slowly to tension the wire rope.

NOTICE

Do not extend or lower the boom. Such operations can cause damage to the jib.

8. Using the jib handle, pull out the connecting pin (H).

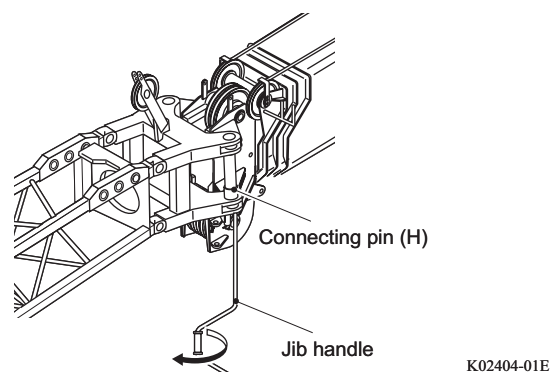

9. Wind down the wire rope to loosen the wire rope slightly.

10. Remove the rope socket from the bracket on the jib.

11. Remove the wire rope from the sheave and guide on the top end of the jib and boom.

 Set the guide pins for the sheave and guide to their original positions, and stow the mast sheave in the jib.

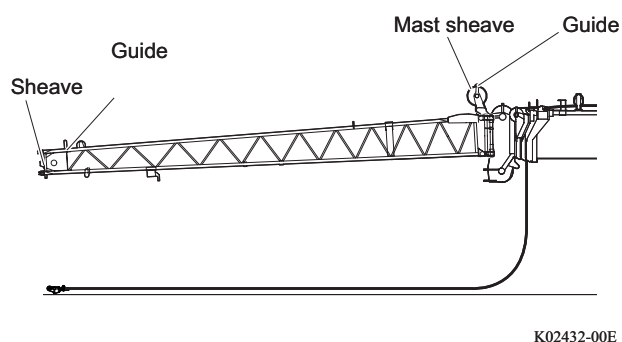

12. Attach a guide rope to the top end of the jib.

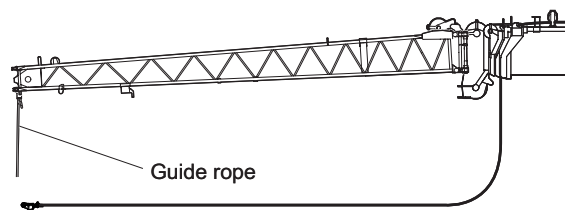

K02433-00E

13. Swing out the stowage support by using the jib mounting/stowing switch.

☞ Release the set pin on the stowage support from the guide to make the pin free.

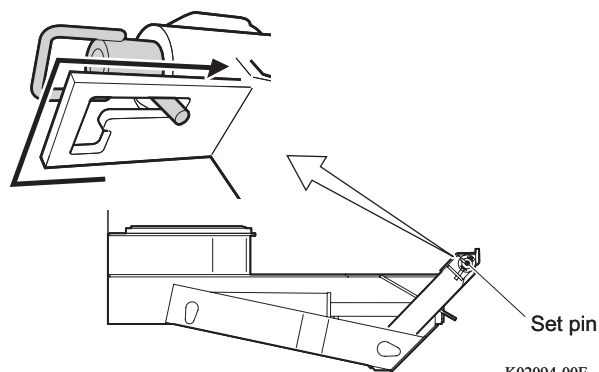

K02094-00E

14. Using the jib handle, hitch the set pin (F) on the guide.

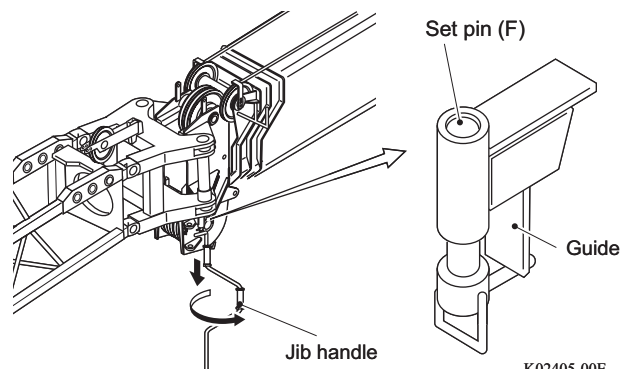

K02405-00E

15. Pull the guide rope and fold the jib to the boom side.

- The set pin of the stowage support is inserted, and the stowage support and base jib are connected.

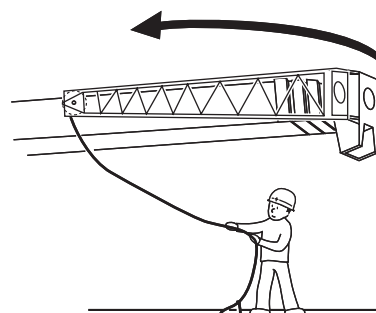



K02095-000

⚠ WARNING
Do not enter the area where the jib swings or under the jib. The jib can move unexpectedly and cause an injury.

NOTICE
Before swinging the jib, be sure to retract the boom fully. Otherwise, the boom can be damaged.

GR-750XL-2_OM2(U)-17E

- 16.** Set the jib mounting/stowing switch to the "stowing" side to draw the jib to the boom side.
- When the jib mounting/stowing cylinder is retracted fully and the jib is folded to the boom, the jib lock icon on the load moment indicator goes out.

-  Full retraction of the jib lock pin is required to operate the jib mounting/stowing cylinder. Check that the jib mounting/stowing operability indicator lamp lights up.
-  When the jib set state is not registered to the load moment indicator, the jib mounting/stowing switch does not work.

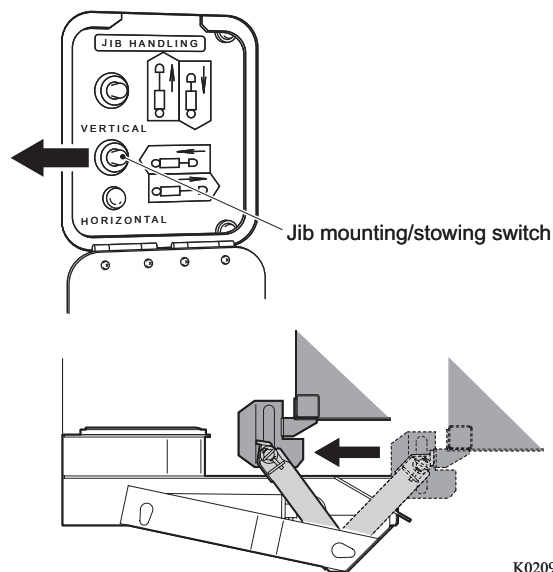

K02096-00E

- 17.** Set the jib lock pin switch to the "extension" side, and let the jib lock pin of the center support engaged to the jib.

⚠ WARNING

Do not remove the pivot pin (G) while the jib lock pin is removed. The jib can fall and cause a serious accident.

-  When the extension of the jib lock pin is completed, the marks on the cylinder (red) and on the jib (blue) of the center support are aligned.

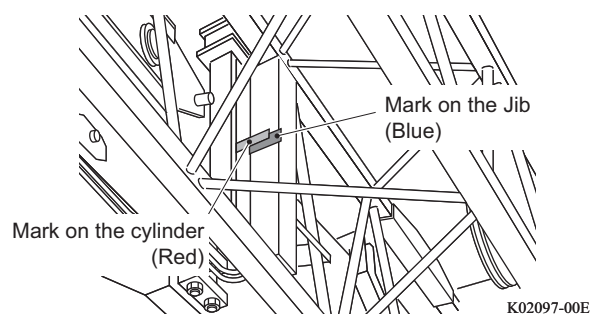
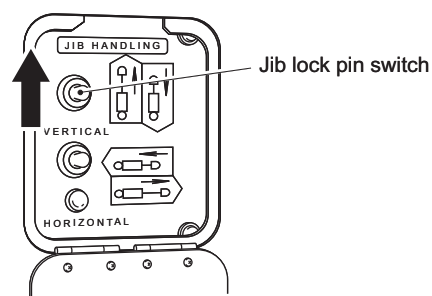

K02097-00E

- 18.** Using the jib handle, pull out the pivot pin (G).

⚠ WARNING

- Check that the boom is set to the horizontal or higher angle before operation. If the pivot pin (G) is pulled out with the boom set below the horizontal angle, the jib may fall.
- To prevent the falling of the jib, carry out the procedure below immediately after the pivot pin is pulled out in order to insert the set pin and to secure the jib.

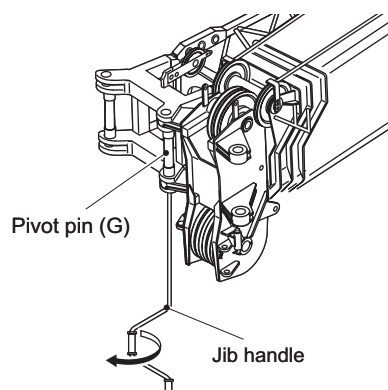

K02406-00E

19. Pull out the set pin of the stowage support.

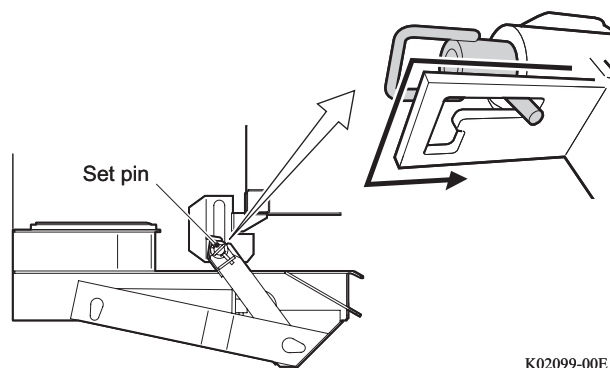

20. Draw the base jib to the boom side until the base jib and top jib are connected with the set pin (E).

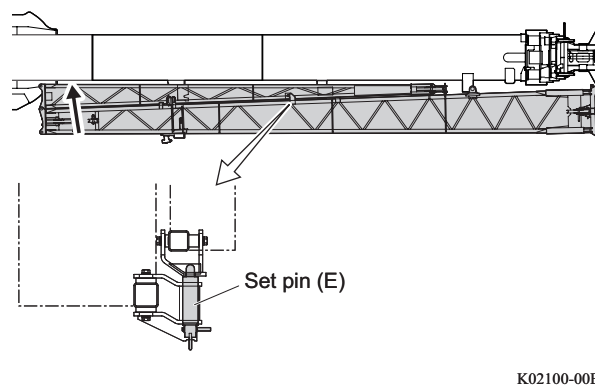

21. Insert the stowing pin (A) for the base jib, and secure it with the snap pin.

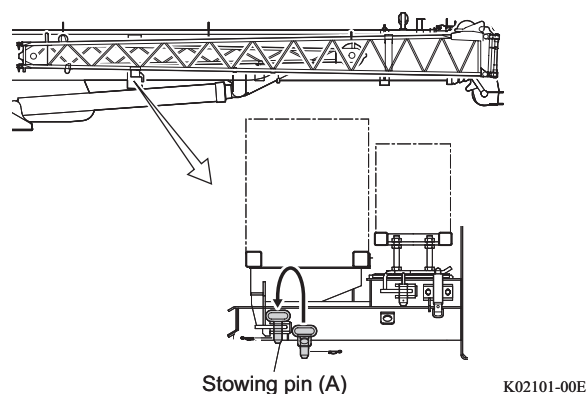

22. Insert the connecting pins (I) and secure them with the snap pins to connect the base jib and top jib.

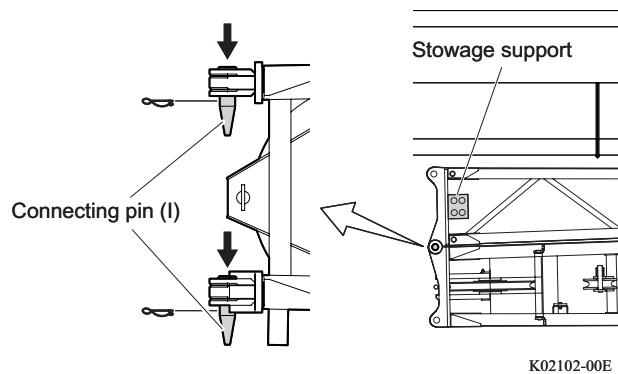

23. Stow the anti-twoblock device.

When the wire rope from the main winch is used:

- (1) Reeve the wire rope through the sheave at the top of the boom, and then set the stowing pin.
- (2) Reeve the wire rope through the main hook block.
- (3) Stow the anti-twoblock device in the tool box.

When the wire rope from the auxiliary winch is used:

- (1) Reeve the auxiliary wire rope through the rope arrester.

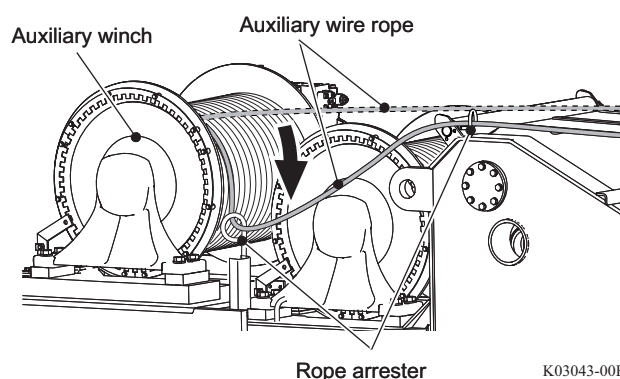

K03043-00E

- (2) Route the auxiliary wire rope as shown in the illustration.

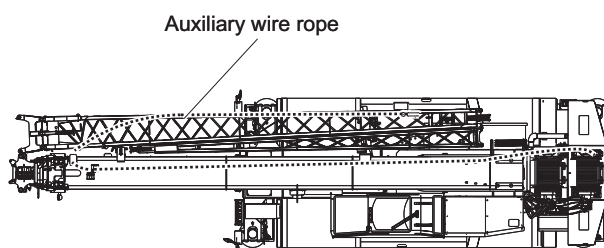

K07056-00E

- (3) Mount the rope socket to the support on the jib, and stow the anti-twoblock device in the tool box.

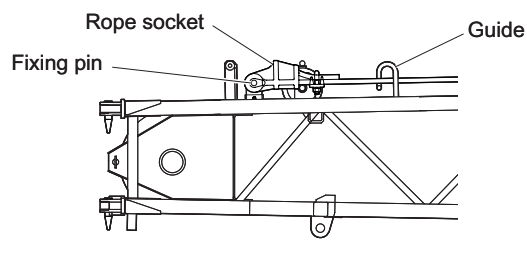

K02962-00E

- (4) Wind up the auxiliary wire rope until the wire rope is loosened slightly.

NOTICE

- Do not wind up the auxiliary wire rope excessively. The support on the jib can be severed off.
- Make sure that the auxiliary wire rope is loosened when stowed. If the rope is tensioned, the wire stowing support can be damaged when the boom is raised.

- 24.** Register the boom lift status to the load moment indicator.

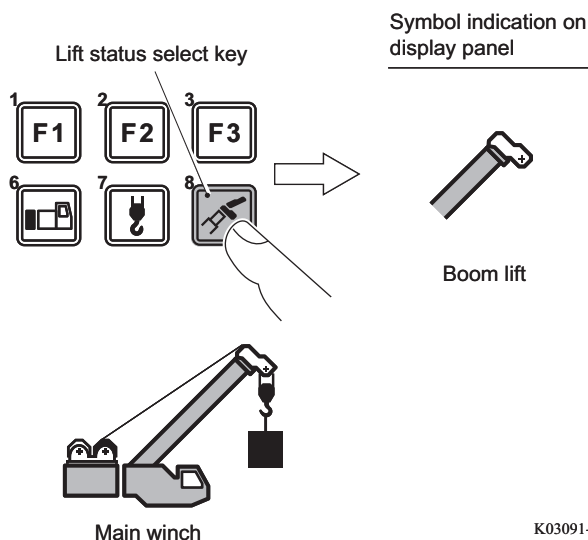

- 25.** Check that the crane automatically stops when the main hook block is overhoisted.

 If the crane does not stop automatically, refer to Step 4 and check that the wiring is connected correctly.

Now, the stowing of the base jib is completed.

Stowing of Base Jib + Top Jib

WARNING

For the basic precautions, refer to the previous section "Stowing of Base Jib."
Observe the precautions in the section "Stowing of Base Jib" during operation.

NOTICE

- Be sure to stow the top jib before stowing the base jib.
Incorrect stowing practice can damage the boom.
- Stow the jib according to the set procedure.
- If the anemometer (option) is attached to the jib head, remove it.
If jib stowing operation is performed with the option mounted, it can damage the machine.

1. Set the machine in the following states.
 - Boom length: Fully retracted
 - Boom Angle: horizontal
 - Jib Offset Angle: 3.5°
2. Remove the set pin (C) and (E) from the guide to make them free.

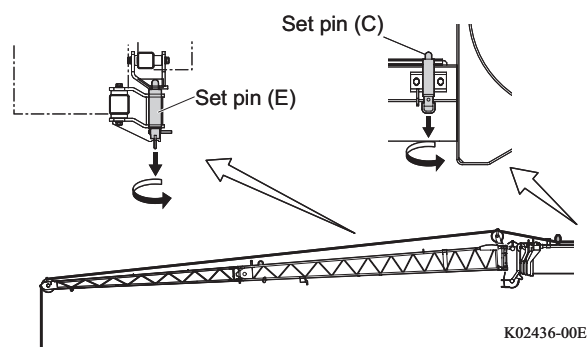

3. Register the jib set state to the load moment indicator.

NOTICE

When the jib set state is registered to the load moment indicator, the automatic stop function does not activate even if the hook block is overwound.

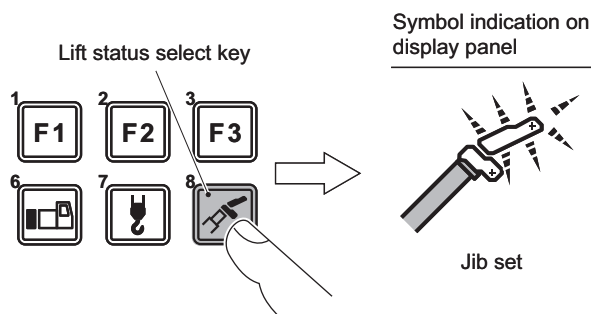

4. Connect the wiring for the anti-twoblock device as shown in the illustration, and remove the twoblocking detection switch from the top end of the jib.

NOTICE

To disconnect the wiring, pull the connector itself, and never pull on the cord. The cord can be broken.

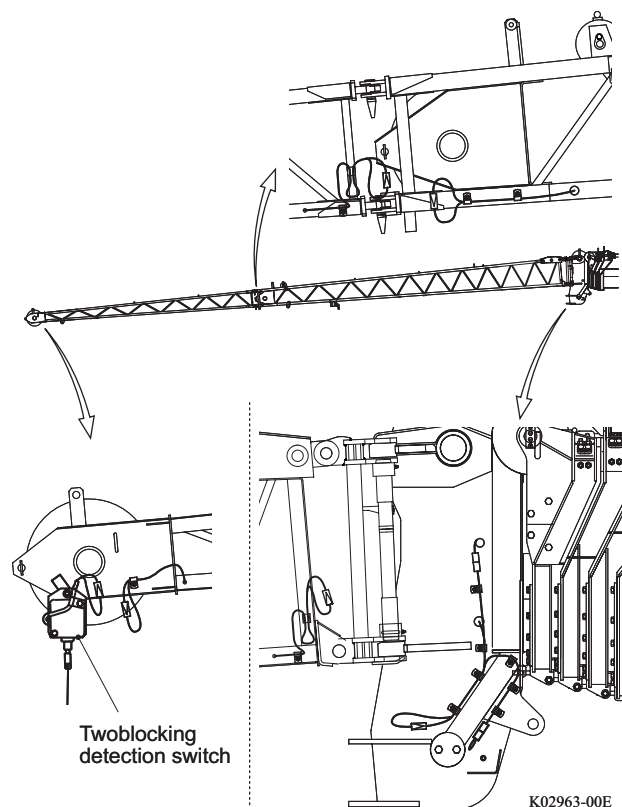

5. Remove the weight from the support on the boom head and remove the pin from the rod for the twoblocking detection switch so that the anti-twoblock device for boom lift can be activated. Stow the removed pin on the support.

WARNING

If you do not pull out the pin inserted in the rod for the twoblocking detection switch, the anti-twoblock device for the main winch does not function during the boom lift.

It can cause the hook block to collide with the boom and a lifted load to fall down, resulting in a serious accident.

Before the boom lift, make sure that the anti-twoblock device functions properly.

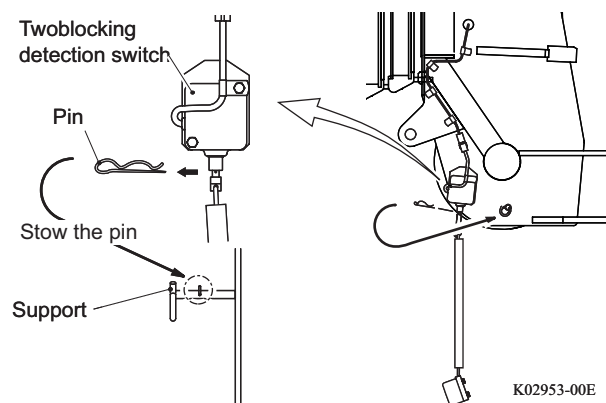

6. Remove the rope socket from the auxiliary hook block.

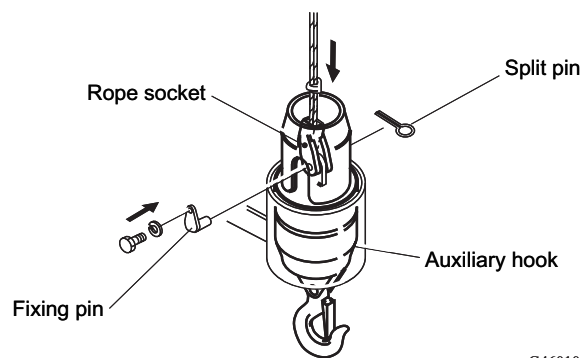

G46010-00E

7. Remove the wire rope from the sheave on the end of the top jib.

 Set the guide pin to the original position.

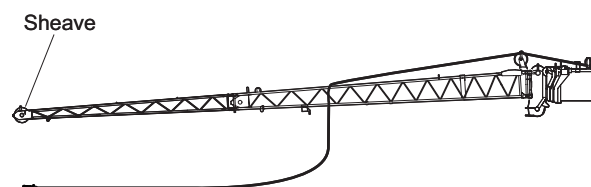

K02437-00E

8. Pull out the left connecting pins (I) that connects the base jib and top jib, and insert the pins to the stowage support and secure them with the snap pins.

 Pull out the connecting pins (I), hitting them lightly with a plastic hammer.

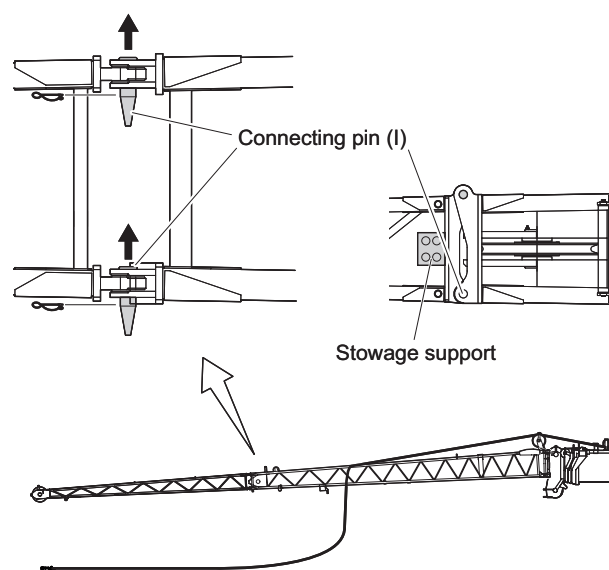

K02438-01E

9. Attach a guide rope to the head of the top jib.

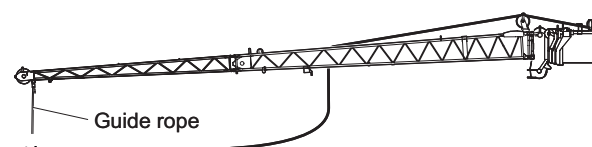

K02111-00E

10. Raise the boom until the boom angle becomes 5° and the jib becomes horizontal.

11. Pull the guide rope to draw the top jib to the base jib side, and check that the top jib and base jib are connected with the set pin (E).

⚠ WARNING
Do not enter the area where the jib swings or under the jib. The jib can move unexpectedly and cause an injury.

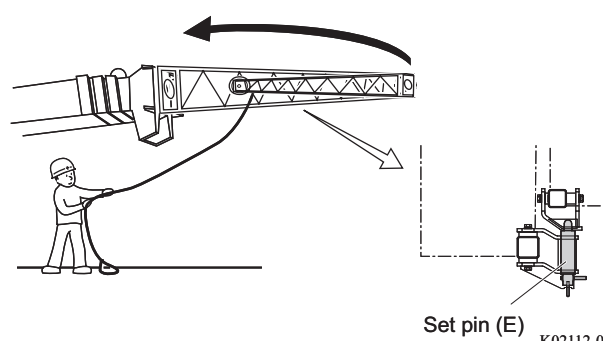

Set pin (E) K02112-00E

NOTICE
Before swinging the jib, be sure to retract the boom fully. Otherwise, the boom can be damaged.

12. Lower the boom to set it horizontal.
13. Remove the guide rope from the head of the top jib.
14. Mount the rope socket to the bracket on the top of the base jib.

NOTICE
Mount the rope socket always as shown in the illustration. If mounted upside down, the rope socket contacts the lower surface of the jib and can be damaged during the hoisting operation.

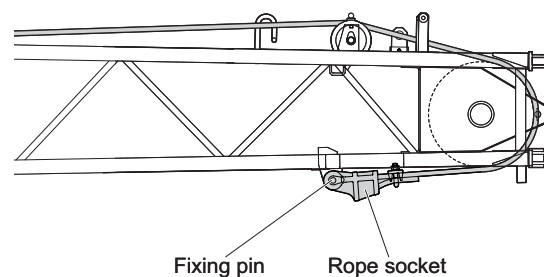

K02088-00E

- 15.** Following the Steps 7 to 18 of the chapter "Stowing of Base Jib", pull out the pivot pin (G).
- 16.** Pull out the set pin of the stowage support, and hitch it to the guide.

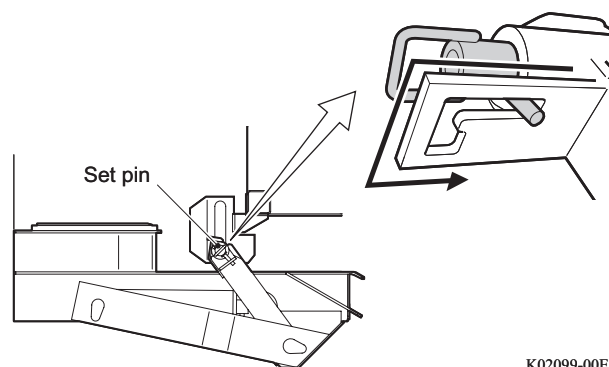

- 17.** Draw the jib to the boom side until the jib is connected to the boom by the set pin (C).

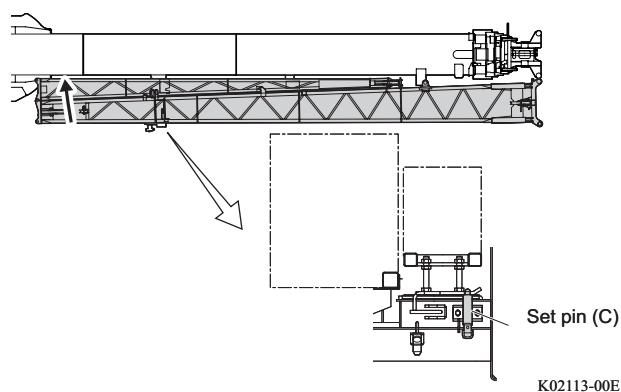

- 18.** Insert the jib stowing pins (A), (B), and (D), and secure them with the snap pins.

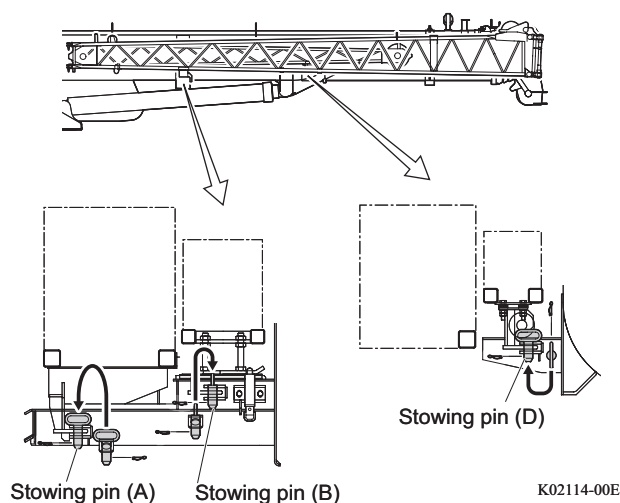

- 19.** Following Step 23 of the chapter "Stowing of Base Jib", stow the anti-twoblock device in the tool box.

- 20.** Register the boom lift status to the load moment indicator.

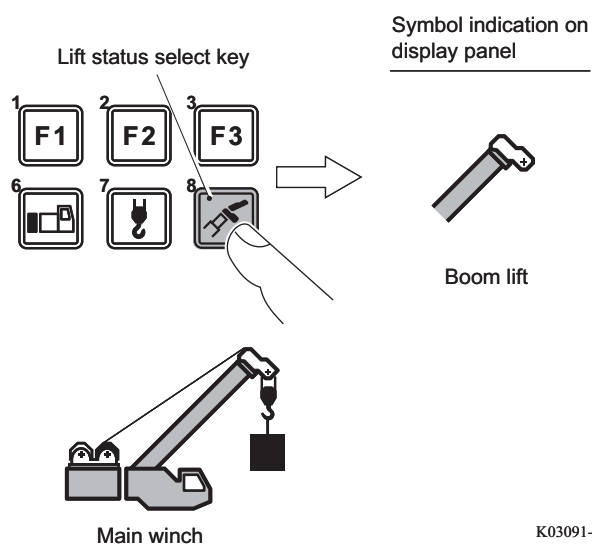

- 21.** Check that the crane automatically stops when the main hook block is overhoisted.

 If the crane does not stop automatically, refer to Step 4 and check the wiring connections.

Now, the stowing of the base jib and top jib is completed.

Dismounting Jib

⚠ WARNING

For the basic precautions, refer to the previous section "Mounting of Base Jib".
Observe the precautions in the section "Mounting of Base Jib" during operation.

NOTICE

- Choose a suitable second crane for dismounting a jib from a boom in consideration of a lifting method and crane operation conditions.

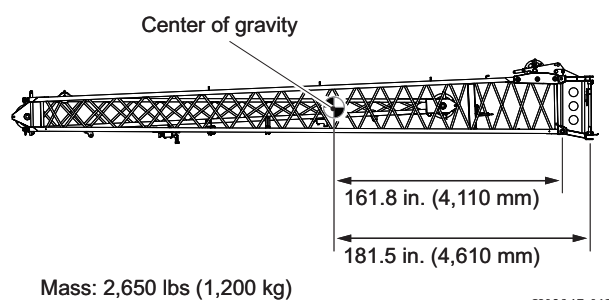

1. Perform Steps 1 to 13 of the chapter "Mounting of Base Jib + Top Jib", and take the jib off from the stowing support.
2. Pull the guide rope and swing the jib to the position where the jib can be lifted up.
3. Support the jib with another crane.

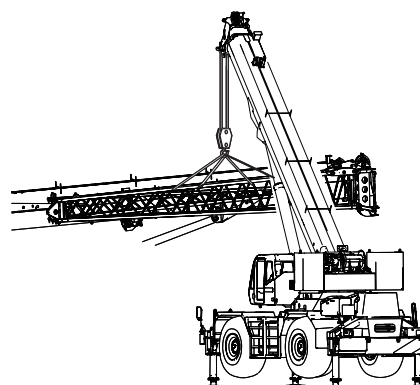

K02964-000

4. Using the jib handle, pull out the pivot pin (G).

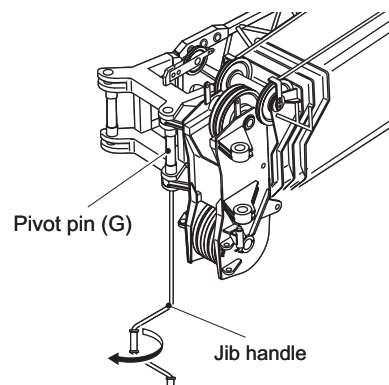

K02406-00E

5. Dismount the jib from the crane body.
6. Set the jib status switch to "REMOVED".
 - The jib dismant icon highlights on the load moment indicator.

⚠ WARNING

If the switch position does not correspond to the actual jib mounting status, the calculation base of the load moment indicator is incorrect, and the machine can overturn or be damaged.

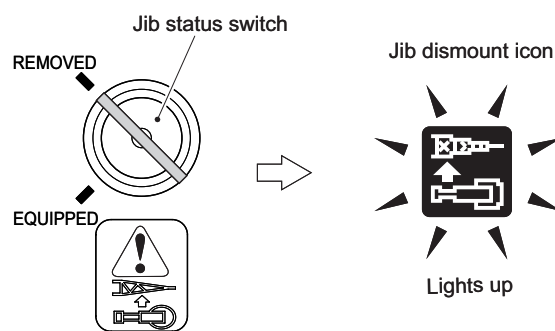

K02117-01E

Mounting Jib

⚠ WARNING

For the basic precautions, refer to the previous section "Mounting of Base Jib".
Observe the precautions in the section "Mounting of Base Jib" during operation.

NOTICE

- Choose a suitable second crane for mounting the jib to the boom according to the of a lifting method and crane operation conditions.

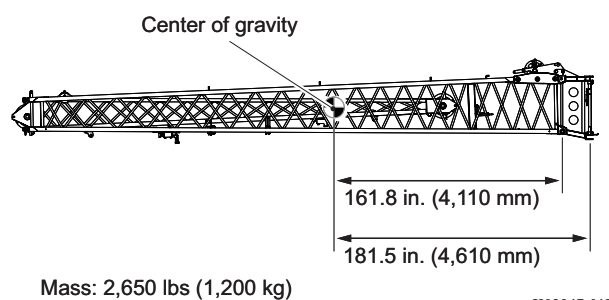

1. Lift up the jib with the other crane, and move the jib to the position where the base jib and pivot pin (G) of the boom can be connected.

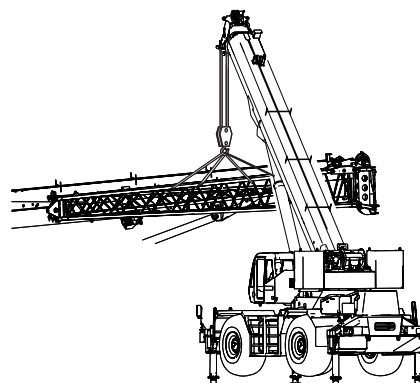

2. Check that the pivot pin (G) is aligned with the pin hole on the base jib, and insert the pivot pin (G) using the jib handle.

- ☞ Insert the pivot pin (G) securely until the red tape on the thread appear.
When the insertion of the pivot pin (G) is completed, the jib lock pin on the center support can be retracted.

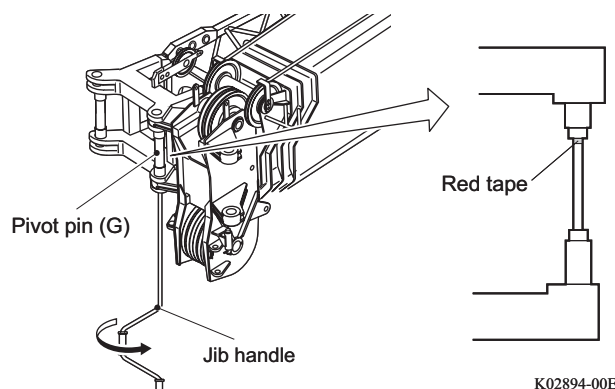

3. Perform Steps 13 to 18 of the chapter "Stowing of Base Jib", and take the pivot pin off from the base jib.

4. Perform Step 15 and afterwards of the chapter "Stowing of Base Jib and Top jib", and mount the jib.
5. Set the jib status switch to "EQUIPPED".
 - The jib dismount icon on the load moment indicator goes out.

⚠ WARNING

If the switch position does not correspond to the actual jib mounting status, the calculation base of the load moment indicator is incorrect, and the machine can overturn or be damaged.

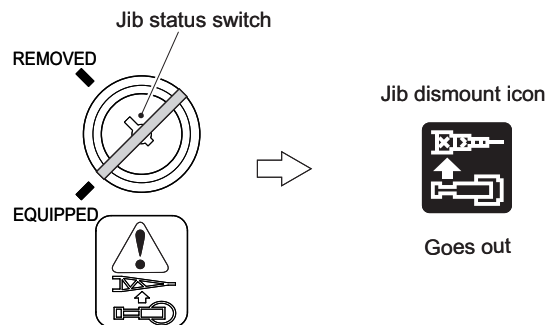

K02118-01E

Mounting and Dismounting Counterweight

⚠ WARNING

**Do not travel or operate the crane without mounting the counterweight.
The crane can overturn due to reduced stability.**

When the crane is transported on a trailer, the load on the trailer axles can exceed the value specified by regulations.

In this case, dismantle the counterweight from the crane.

Mass of counterweight	12,500 lbs (5.7 t)
-----------------------	-----------------------

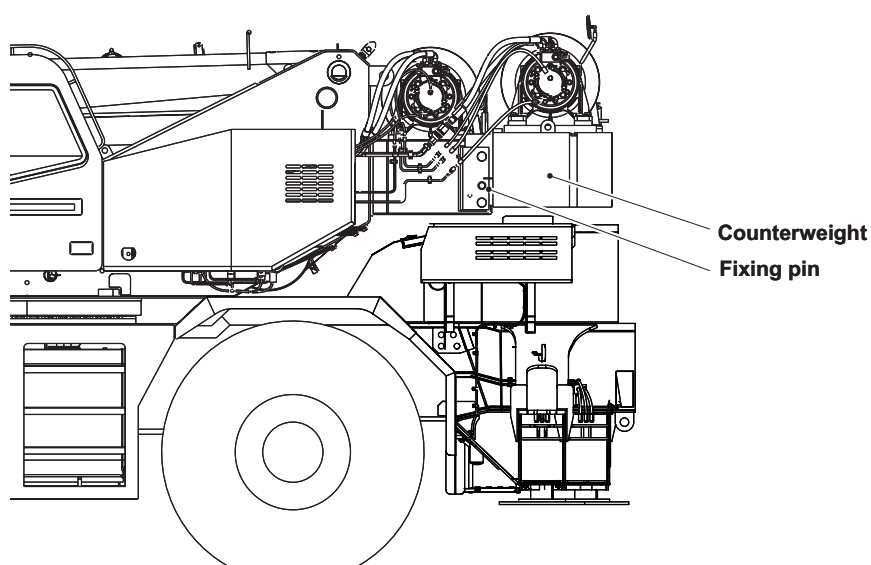

K07042-00E

Dismounting Counterweight

⚠ WARNING

- Do not enter the area under the counterweight during dismounting counterweight. If the counterweight falls, a serious accident can occur.
- Wear a safety belt during inserting/removing counterweight fixing pins, and during slinging work, in order to prevent a falling accident.
A falling accident during these operations can cause a serious injury.
- Do not climb up or leave objects on the counterweight during counterweight dismounting operation.
The counterweight may tilt to one side, resulting in a falling accident or damaging the machine.
- Watch out for a hydraulic oil leak from hoses when you remove the connectors of hydraulic hoses.
If the operation is continued while the spilled oil is left, it can cause a fire. Immediately remove hydraulic oil if it leaked. Do not bring fire nearby when you remove the connectors of hydraulic hoses.

NOTICE

When you remove the connectors of hydraulic hoses, turn the collar until the notch in the collar meets the pin on a hose connector.

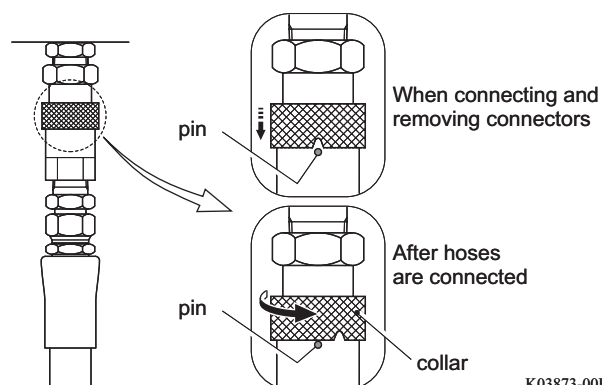

1. Extend the outriggers fully, and set up the crane horizontally.
2. Remove the auxiliary wire rope from the boom, and attach it to the stowing support.

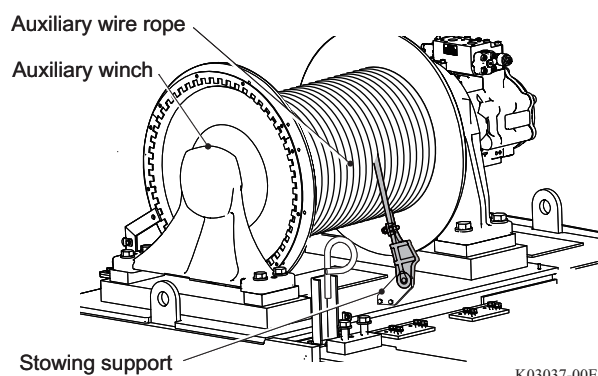

3. Disconnect the connectors of the hydraulic hoses and wiring for the auxiliary winch from (1) to (6) in order, by referring to the illustration on the right.

- Put waterproof caps on the detached connectors.

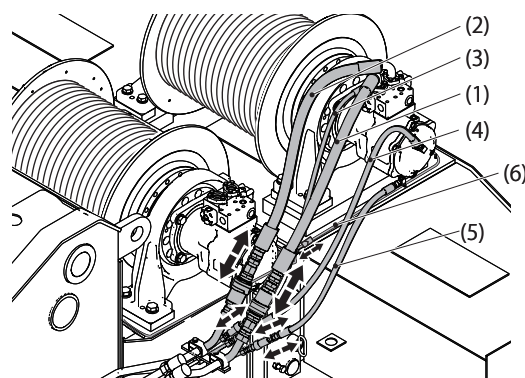

K03046-00E

CAUTION

The engine muffler and winch speed reducer are very hot immediately after the operation, and you may suffer burns if you work on them. Be careful not suffer a burn.

4. Swing the boom 90° clockwise or counterclockwise.
5. Set the swing brake switch to "ON".
- The indicator lamp built in the switch lights up.

Swing brake switch

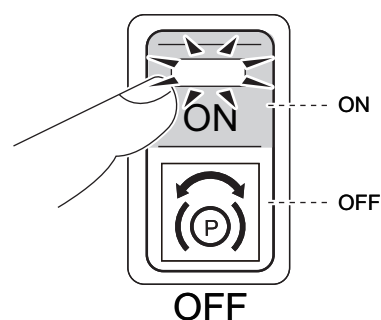

K01926-01E

6. Attach the hoisting attachments to the brackets (two points) on the upper surface of the counterweights.

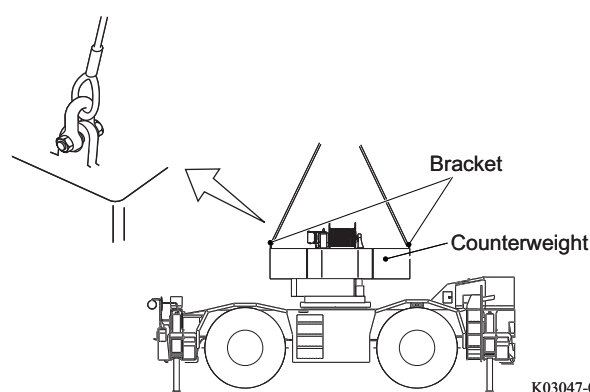

K03047-00E

7. Support the counterweight until a rigging rope is slightly stretched by the second crane.

8. Loosen the anti-oscillation bolts at the right/left sides of the counterweight (2 points each) until the bolts come out by approximately 1/4 in. (6 mm).

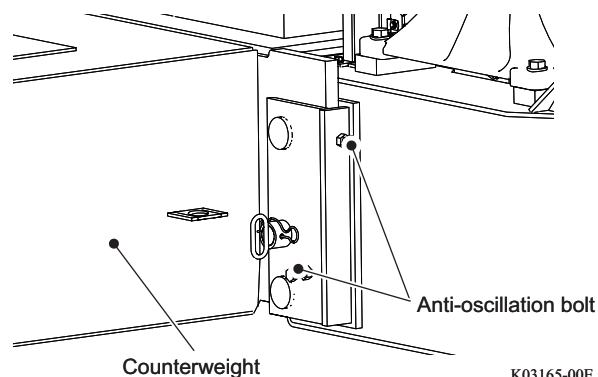

K03165-00E

9. Remove the anti-oscillation bolts on both sides of the counterweight and secure them on the stowage support.

 If the fixing pins cannot be removed, lift up the counterweight slightly by a second crane.

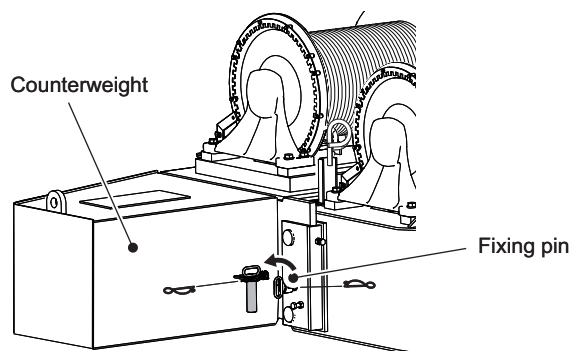

K03048-00E

10. Lift up the counterweight by a second crane and put it on a carrier truck.
 - When the fixing pins are removed, the engine overrun warning lamp lights up and the warning alarm sounds.

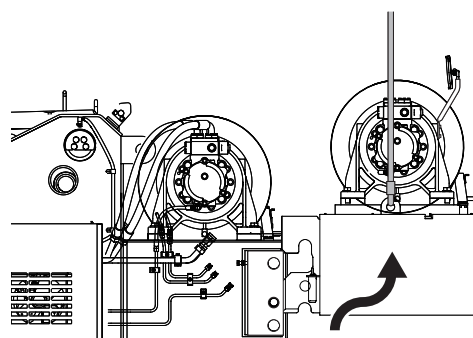

Lights up

K03049-00E

11. Push the counterweight select key.
 - The pop-up window for counterweight status registration appears on the display panel.

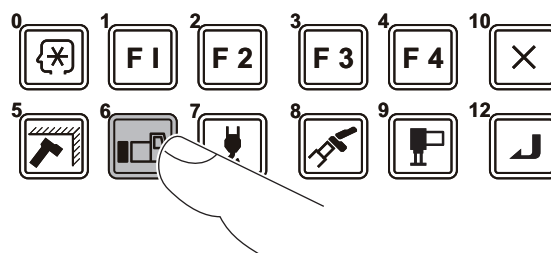

K02531-000

- 12.** Make sure that the displayed mass of counterweight corresponds with the actual crane condition.

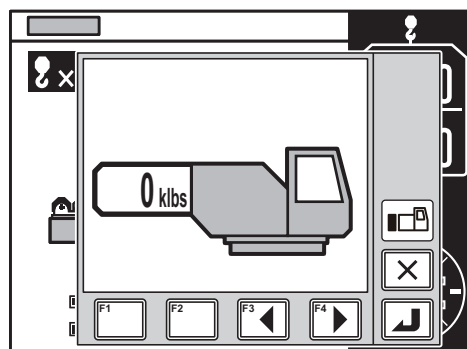

K03596-000

- 13.** Push the set key to register the setting.
- After the registration is completed, the pop-up window closes.

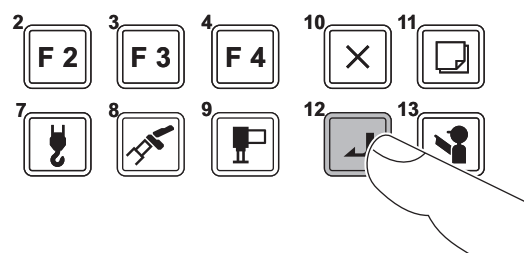

K00678-000

- 14.** Swing the boom to over front area.

15. Load the crane onto a trailer.**⚠ WARNING**

When the counterweight is not mounted, do not drive the crane at a speed of 2.5 mph (4 km/h) or over.

The crane can overturn or be damaged, causing a serious accident.

☞ If traveling speed exceeds 2.5 mph (4 km/h), an alarm buzzer sounds.

☞ If you cannot see the road surface due to the boom while traveling in a work site, set the boom in the state below, and refer to the section "On-rubber Creep Operation" (page 223).

- Boom length: 36.1 ft. (11 m)
(fully retracted)
- Boom angle: 40° or under
- Swing angle: Front (the front position symbol on the load moment indicator lights up)

Do not travel in a work site with other than the state of the crane explained above.

Mounting Counterweights

⚠ WARNING

- Do not enter the area under the counterweight during mounting counterweight. If the counterweight falls, a serious accident can occur.
- Wear a safety belt during inserting/removing counterweight fixing pins, and during slinging work, in order to prevent a falling accident. A falling accident during these operations can cause a serious injury.
- Do not climb up or leave objects on the counterweight during counterweight dismounting operation. The counterweight may tilt to one side, resulting in a falling accident or damaging the machine.

1. Extend the outriggers fully, and set up the crane horizontally.
2. Swing the boom 90° clockwise or counterclockwise.
3. Set the swing brake switch to "ON".
 - The indicator lamp built in the switch lights up.

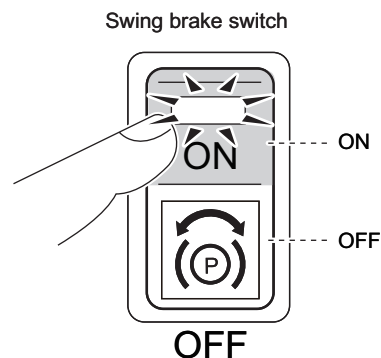

K01926-01E

4. Lift up and carry the counterweight with a second crane to the counterweight mounting position at the back side of the swing frame.

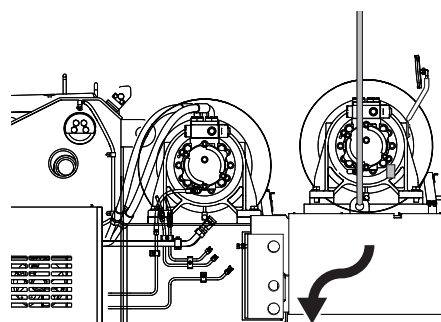

K03050-00E

5. Fix the counterweight to the machine with the fixing pins that are located on both sides of the counterweight (2 points), and secure them with snap pins.
- When the counterweight is fixed to the crane, the engine overrun warning lamp goes out, and the warning alarm sounds.

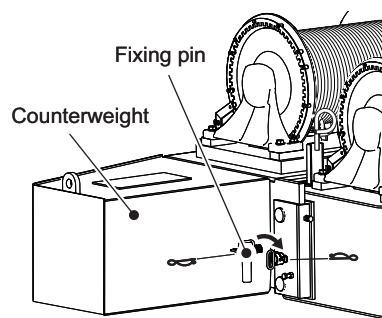

Goes out

K03051-01E

6. Tighten the anti-oscillation bolts on both sides of the counterweight.

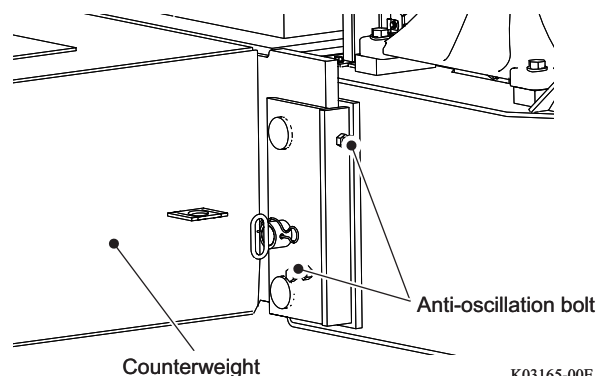

K03165-00E

7. Remove the hoisting attachments from the brackets (two points) on the upper surface of the counterweights.
8. Connect the connectors of hydraulic hoses and wiring for the auxiliary winch from (6) to (1) in order, by referring to the illustration.

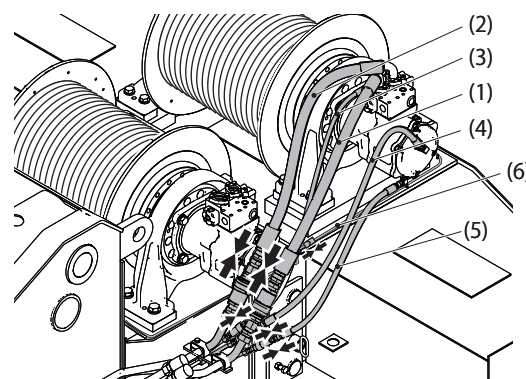

K03052-00E

CAUTION

The engine muffler and winch speed reducer are very hot immediately after the operation, and you may suffer burns if you work on them. Be careful not suffer a burn.

9. Remove the auxiliary wire rope from the boom, and attach it to the stowing support.

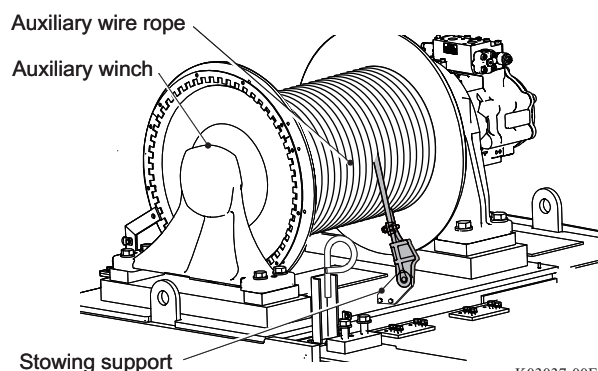

K03037-00E

- 10.** Mount the rope socket for the auxiliary wire rope to the support on the jib.

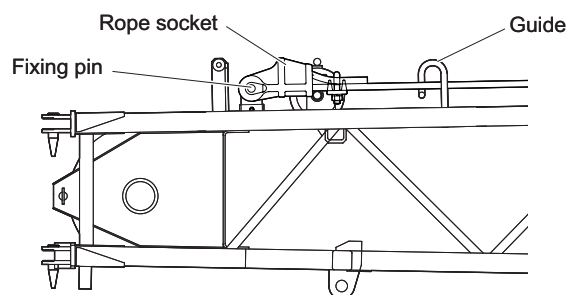

K03053-00E

- 11.** Push the counterweight status select key.
- The pop-up window for counterweight state registration appears on the display panel.

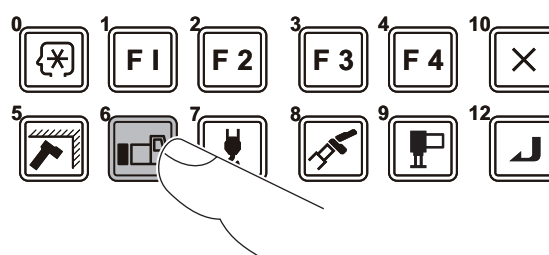

K02531-000

- 12.** Check that the value of the counterweight indicated on the load moment indicator agrees with the actual crane state.

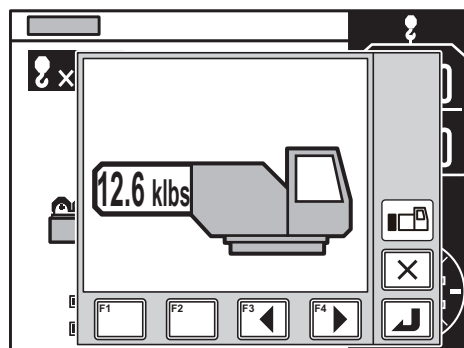

K02923-000

- 13.** Push the set key to register the setting.
- After the registration is completed, the pop-up window closes, and the load moment indicator returns to the crane operation state.

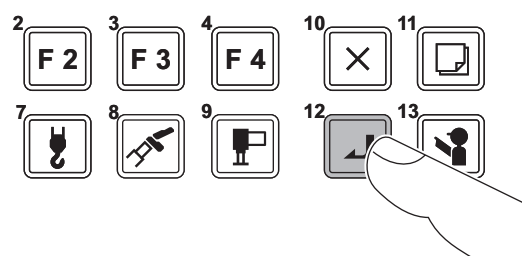

K00678-000

Accessories in Cab

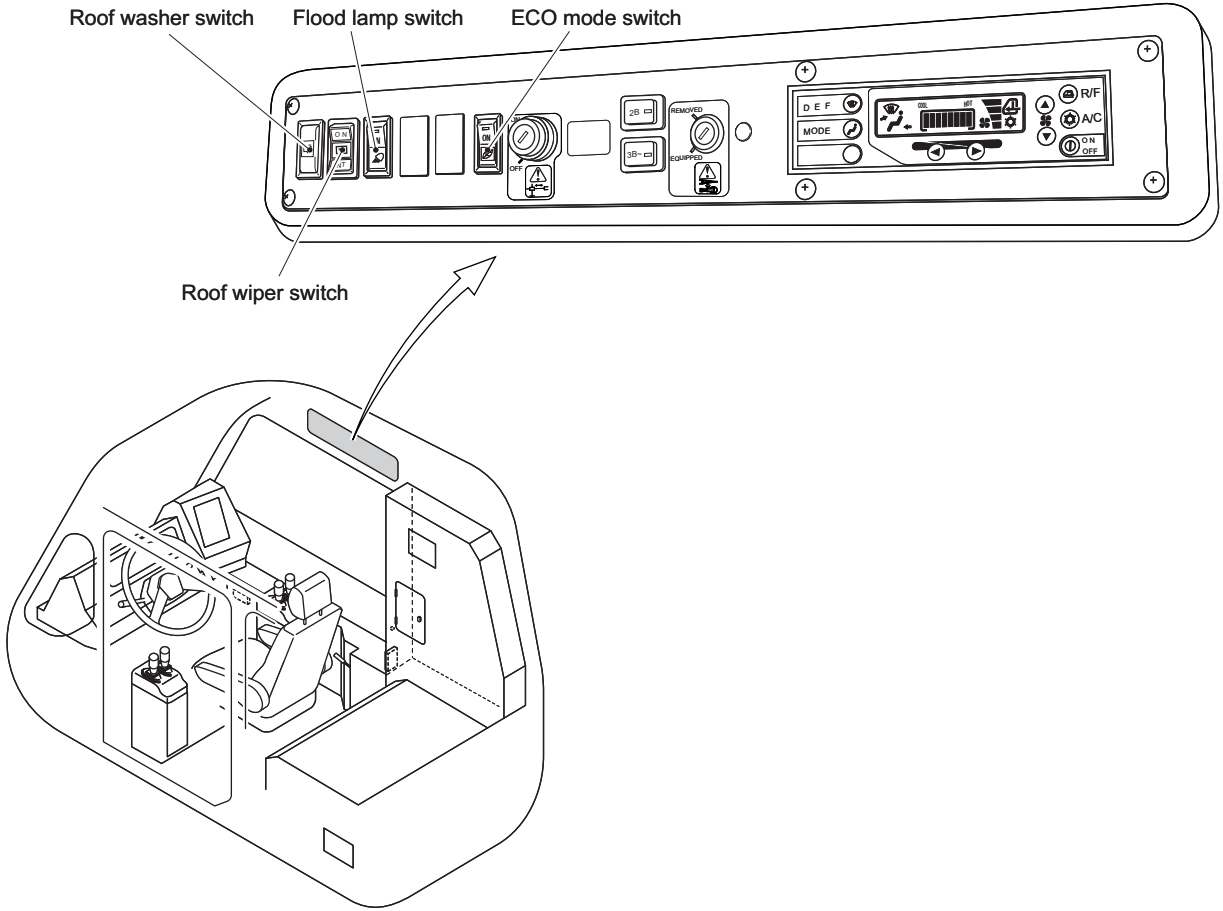

K02944-01E

Flood Lamp Switch

Use this switch during night operation.

When this switch is turned "ON", the work lamp (the lamp on the top front of the cab) lights up.

NOTICE

Turn off the work lamp while traveling on a road.

Flood lamp switch

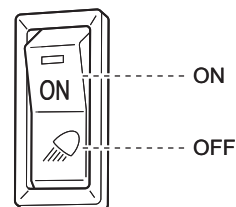

K01971-00E

Roof Washer Switch

While this switch is pressed, the washer liquid is sprayed to the roof glass.

Release the switch to stop spraying.

- ☞ If the washer liquid does not come out, do not keep pressing the roof washer switch. The washer fluid pump will be damaged. Check the washer liquid level and clogging of the washer nozzle.

Roof washer switch



K01974-00E

Roof Wiper Switch

When this switch is set to the "ON" or "INT" side, the roof wiper is operated.

- "ON" side..... Continuous operation
- "INT" side Operated every 3 to 5 seconds

- ☞ If the wiper is moved on a dry glass, the glass is scratched. Spray washer liquid before you operate the wiper.
- ☞ When the glass is frozen or the wipers are not used for a long time, make sure that the wiper blades do not stick to the glass. If you operate a wiper while its blade is stuck to the glass, the blade will suffer damage.

Roof wiper switch

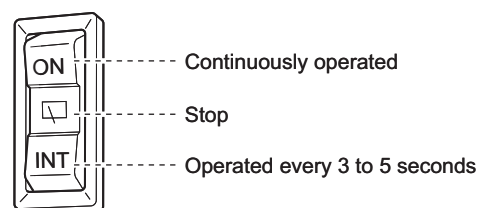



K01975-00E

ECO Mode Switch

In this mode, you can control the machine fuel consumption and the noise from the crane operation.

While the ECO Mode Switch is on, the maximum engine speed is controlled, and the fuel consumption and the noise from the crane operation are reduced.

 A crane operation becomes slower by restricting the maximum engine speed. Select a suitable ECO mode according to a crane operation.

 You can choose an ECO crane operation mode from 2 ECO modes, when the ECO mode switch is on. Refer to the "Load Moment Indicator (AML)" (page 137).

ECO mode switch

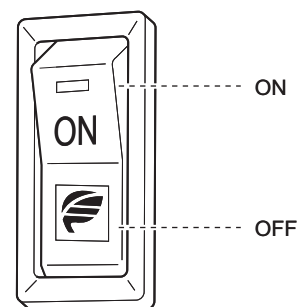

K03166-00E

Searchlight (Option)

NOTICE

- Do not use the searchlight for a long time while the engine is stopped, or the battery can be exhausted.
- Turn off the searchlight while traveling on a road.

Use this switch during night operation.

Refer to the separate operation manual for the searchlight usage.

Top of base boom

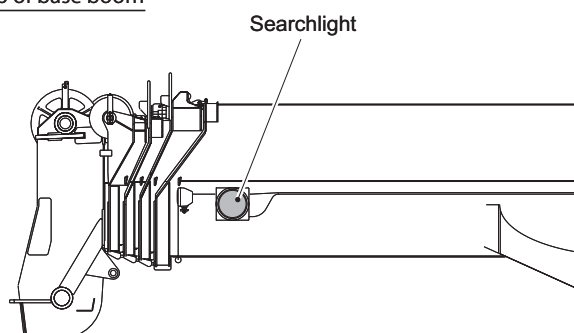

Inside Cab

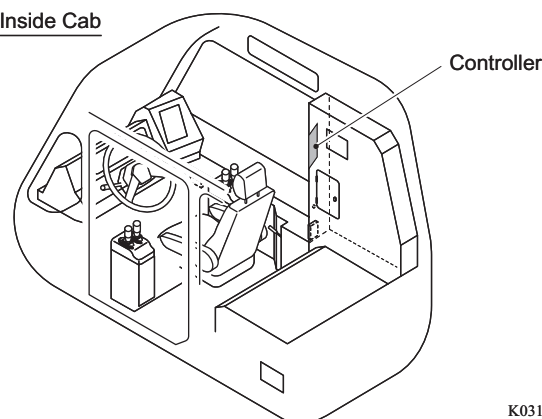

K03157-00E

Turn on the Searchlight and Change the Beam Direction

1. Push the "LIGHT/POWER" switch on the remote controller.
 - The searchlight turns on.

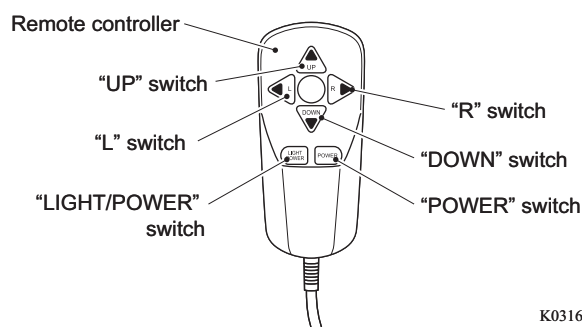

K03160-00E

2. Push "L", "R", "UP" or "DOWN" switch. The reflector of the searchlight moves accordingly and changes the beam direction.
3. To turn off the searchlight, push "LIGHT/POWER" switch.

Change the Beam Direction Without Turning on the Searchlight

1. Push "POWER" switch on the remote controller.

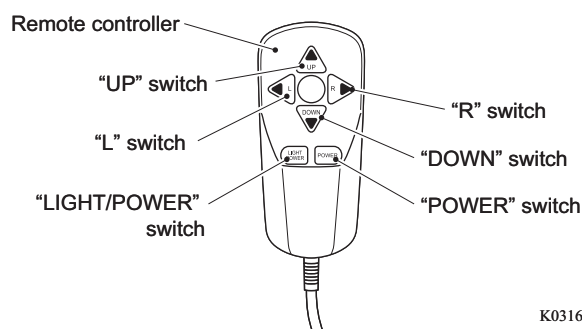

2. Push "L", "R", "UP" or "DOWN" switch. The reflector of the searchlight moves accordingly and changes the beam direction.

 Push "LIGHT/POWER" switch on the remote controller to turn on the searchlight.

K03160-00E

Accessories Outside of Cab

Winch Drum Monitoring Mirror

NOTICE

If a load is hoisted up with the wire rope wound disorderly on the winch drum, the wire rope can be damaged, shortening the life of the wire rope.

Do not hoist up the load when the wire rope is wound disorderly.

You can monitor the winch drum with these mirrors.
Adjust the mirror on the ceiling of the cab and the mirror on the winch so that the winch drum can be monitored.

Winch drums

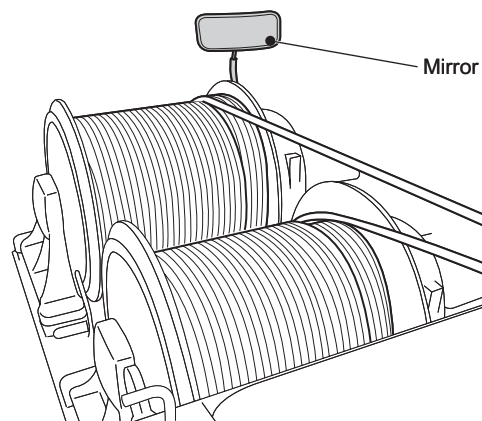

Cab ceiling

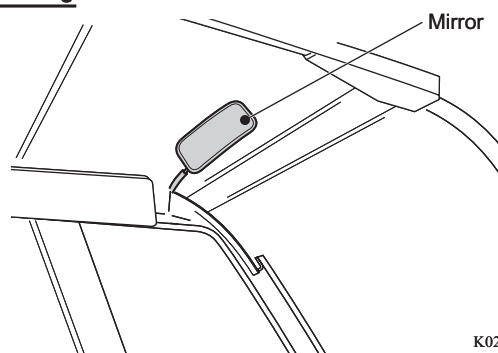

K02945-01E

INSPECTION AND MAINTENANCE



Precautions for Inspection and Maintenance

⚠ WARNING

This section describes the precautions necessary to prevent accidents during inspection and maintenance of the machine. For specific precautions, refer to the corresponding paragraphs in the main text of this manual (white pages).

Illustrations supplement the precautions and show you where the important points are. Note that the shapes, etc. in the illustration can be different from the actual machines.

Precautions for Inspection and Maintenance

• Perform Inspection and Maintenance on a Level Ground

If the machine is parked on a slope, the machine cannot be inspected correctly. Also, the machine can move by its own weight and cause a caught-in accident.

When you carry out inspection and maintenance of the machine, park the machine on a level and firm ground, and set the stoppers to the tires.

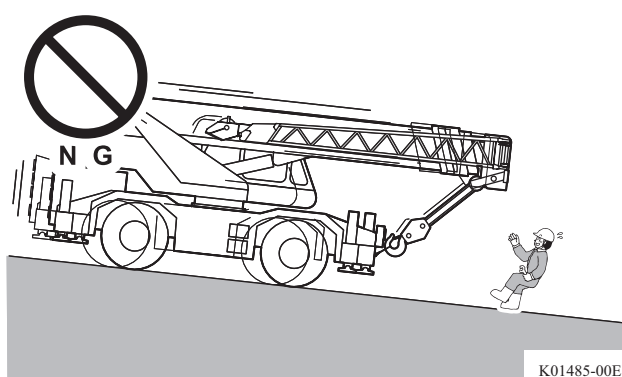

• Set Stoppers to Tires

If the parking brake is not securely applied, or the stoppers are not set to the tires, the vehicle can start moving, causing an unexpected accident.

Securely apply the parking brake, set the shift lever to "N", and set the stoppers to the tires.

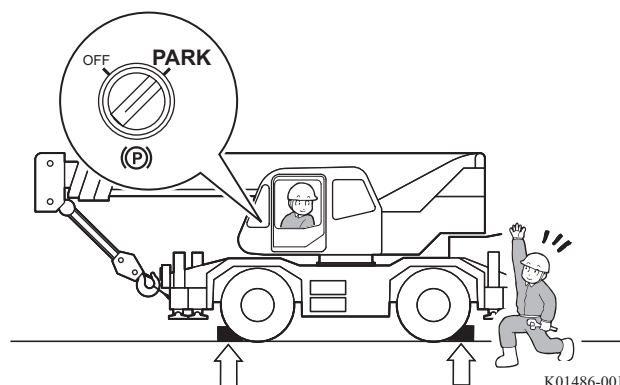

• Pay Attention to Ventilation

When you work indoors or in a poorly ventilated place, you must be careful of gas poisoning. Exercise extreme caution when handling fuel, washing oils, and paints. Particularly, proper ventilation is required when the engine is started indoors. Extend the exhaust pipe outdoors, and open the doors and windows to allow sufficient fresh air to enter. Install a ventilator as necessary.



• Stop the Engine during Inspection and Maintenance

If you touch or come near to a rotating part of an engine while it is running, your hands or clothing can be caught, resulting in an injury. Be sure to stop the engine before inspecting the machine.

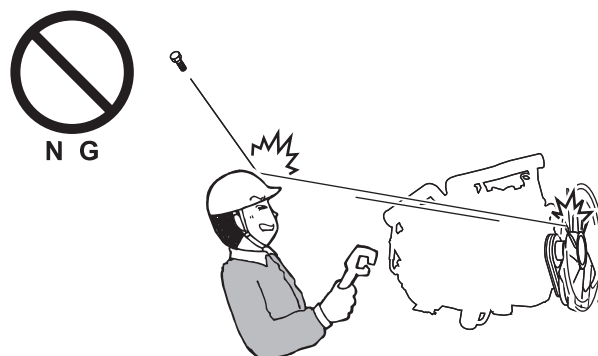

G61004-00E

• Keep Away from Moving Parts

If someone operates the machine unawares of the ongoing inspection, or if you touch a moving part, you can be caught by the machine. It is extremely dangerous. If inspection and maintenance must be performed with the machine operated, keep away from the movable parts such as the boom, boom elevating cylinder, winch, fan, fan belt, propeller shaft, etc. In addition, allow no one to gain access to these parts. When you have to work near movable parts, be extremely careful so that your hands or clothing do not touch the movable parts.

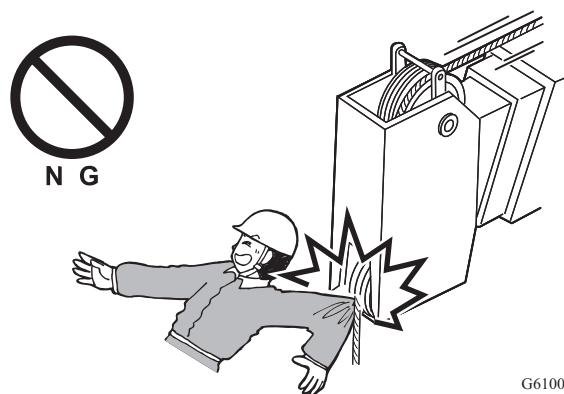

G61005-00E

• Wash the Machine before Inspection and Maintenance

If the machine is soiled, it is difficult to find a faulty part, and the dirt enters the machine easily during inspection and maintenance. In addition, dust or mud can get into your eyes, or your feet can slip, resulting in an injury. Before inspection and maintenance, wash the machine.

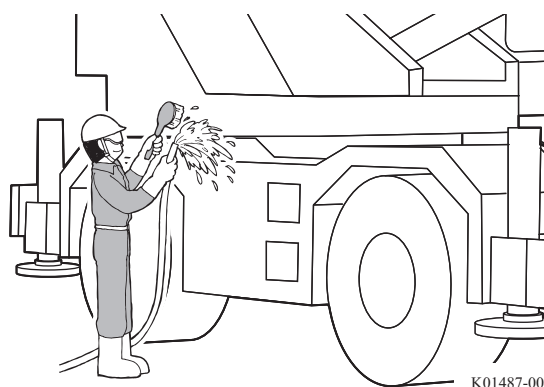

K01487-000

• Precautions for Washing the Machine

If water is sprayed on the area where high-pressure washing is prohibited, it can cause a short circuit and a failure. Do not spray water on the area where high-pressure washing is prohibited.

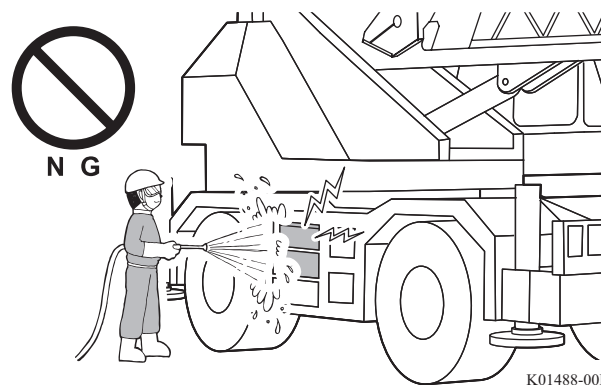

K01488-00E

• Keep the Work Site Tidy and Clean

Inspection and maintenance in a disorderly work site poses a risk of injury and a falling accident.

Put away objects which can hinder the work.



K01489-00E

• Indication of Being under Inspection and Maintenance

If an unauthorized person carelessly starts the engine during inspection and maintenance, it can cause damage to the machine, a physical injury, or death.

Hang a warning tag on the door or on the control levers in the cab to notify the others that the machine is being inspected and maintained.

Also, place tags around the machine to keep the unauthorized people away from the inspection and maintenance site.

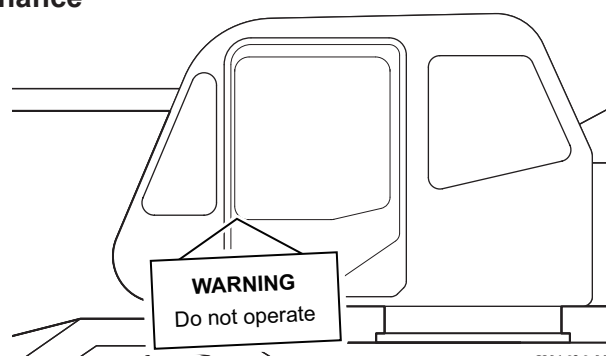

K01626-00E

• Lock the Inspection Cover

If covers or doors such as the inspection cover are left open, they can close suddenly by gusts of wind, and you can be pinched and injured.

After opening the inspection cover, doors, and cab doors, lock them.

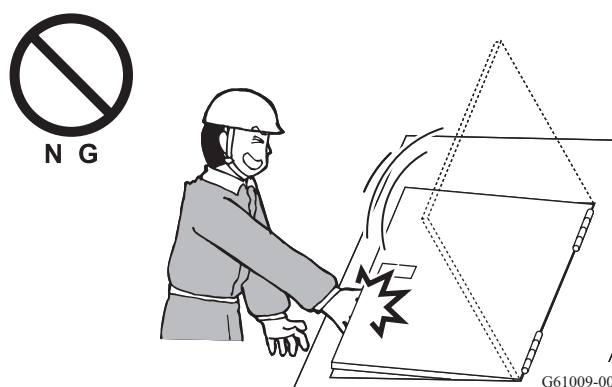

G61009-00E

• Watch Your Head and Step

If your attention is distracted, or if you walk on a surface with poor footing, you can hit your head against the overhead objects such as the hook block, boom, and jib, or your feet can slip, resulting in a falling accident.

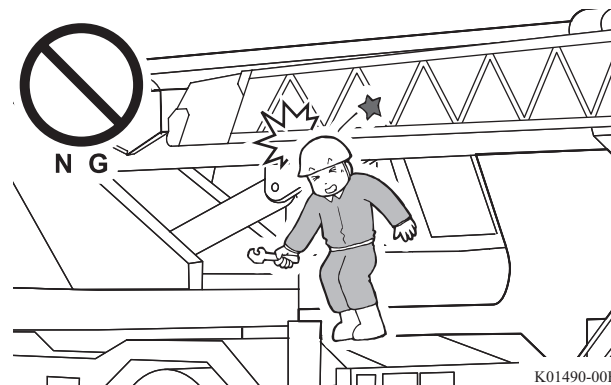

K01490-00E

• Precautions for Inspection and Maintenance at a High Place

Inspection and maintenance operation at an elevated place poses a risk of a falling accident.

When you work at an elevated place, use a platform to prevent a falling accident. Falling from an elevated place can result in a serious injury.

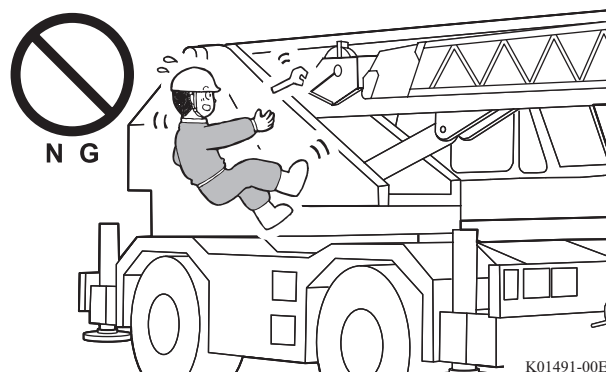

K01491-00E

• Precautions for Inspection and Maintenance Under the Machine

If it is necessary to work under the machine with the jack cylinders extended, put props or wood blocks under the outriggers to support the machine securely and to prevent the machine from lowering even if the jack cylinders retract.

If the machine body is not held securely, do not perform any operation under the machine. If the machine lowers, a caught-in accident can occur.

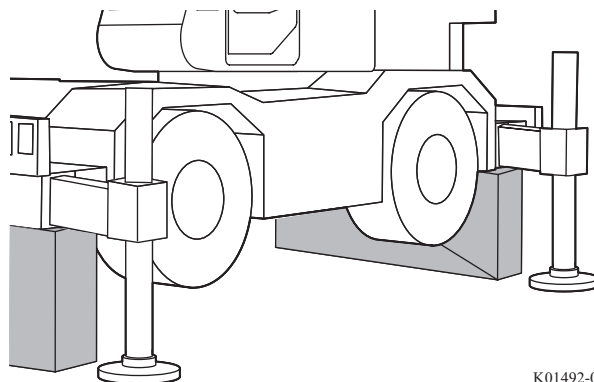

K01492-000

• Start Operation after Temperature Drops

Do not touch hot components such as exhaust pipes and radiator immediately after the engine is stopped. You may suffer burns. Start operation after each component has sufficiently cooled down.

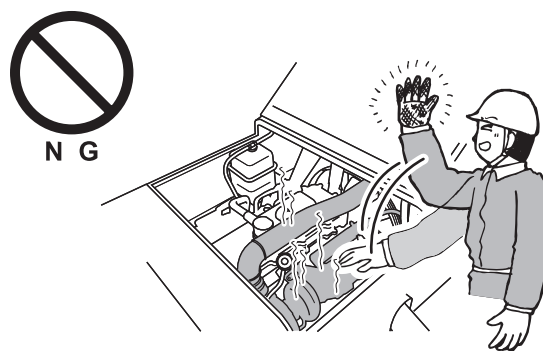

G61013-00E

• Keep Surroundings of the Engine Clean

Check that rags, gloves, and tools are not left in the engine room. Flammable objects such as pieces of cloth can catch fire. In addition, tools can bounce due to vibration and damage the components.

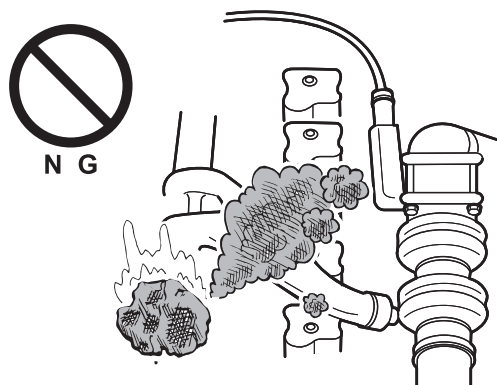

G05015-00E

• Do Not Drop Tools and Parts

When you work with the inspection cover opened, be careful not to drop objects into it. If you drop objects inadvertently, it can cause machine damage or malfunctions. After inspection and maintenance, always check that nothing is dropped in the machine.

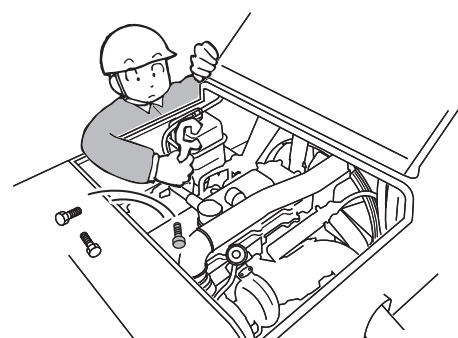

G61014-00E

• Watch Out for High-Pressure Oil

If you directly touch the high-pressure fuel or hydraulic oil, it can cause a serious injury. Pay attention to the precautions below.

- Release the internal pressure before disconnecting the piping.
- To check leakage, wear protective glasses and protective gloves, and use pieces of cardboard or wood. It is dangerous to perform inspection with bare hands.
- If oil gets into your eyes or mouth accidentally, immediately seek medical attention.

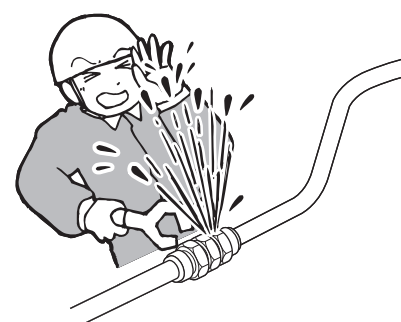

G61015-00E

• Watch Out for Dust

Do not inhale the dust raised during operation. Wear a dust mask during operation. Before you perform inspection and maintenance for the brakes and lining, remove the dust with a vacuum cleaner. Do not use compressed air, which disperses the dust into the air.

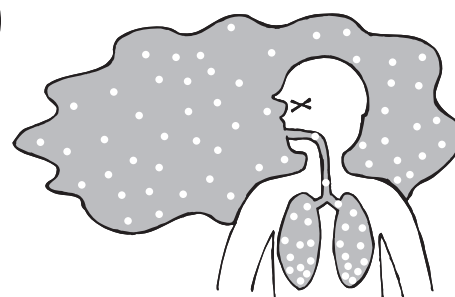

G61016-00E

• Do Not Perform Welding on the Machine Body

Welding work (electric welding) on the machine body can damage the electrical and electronic equipment. Never perform welding on the machine body.

When a welding work (electric welding) must be performed, contact your nearest TADANO distributor or dealer to have the work done.

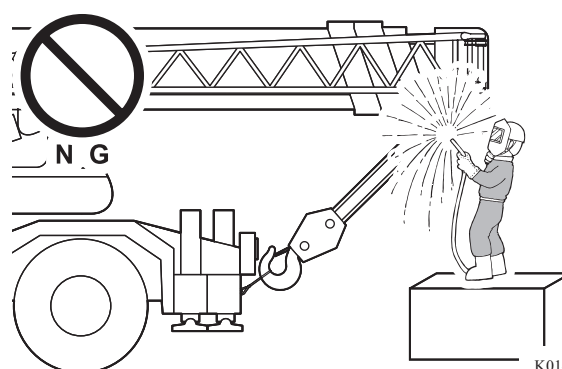

K01493-00E

• Prevention of Fire

You handle flammable and hazardous objects such as fuel and batteries during inspection and maintenance. Observe precautions below to prevent a fire.

- Use nonflammable cleaning liquid to clean parts.
- Keep oils and greases away from a fire for storage.
- Extinguish flames (such as a lit cigarette) that can cause a fire.
- Keep fire fighting equipment such as fire extinguishers at the ready.
- Use explosion-proof illuminating equipment when you inspect fuel, oil, and battery electrolyte.
- Particularly during grinder and welding work, keep hazardous objects away and watch out for a fire.



• Illumination

If you work under insufficient illumination, an injury can occur. Provide sufficient illumination for operation.

Do not use a match, cigarette lighter, or other open flame for illumination purposes. They can cause a fire, or the gas from the battery can be ignited and explode.

Use explosion-proof illuminating equipment when you inspect fuel or battery electrolyte.



• Avoid Adherence of Oil and Grease

If oil or grease adheres to the lining or disk of the clutch or brake, the braking force will be reduced and creates hazardous situations. Be careful not to allow oil or grease to adhere to these surfaces.

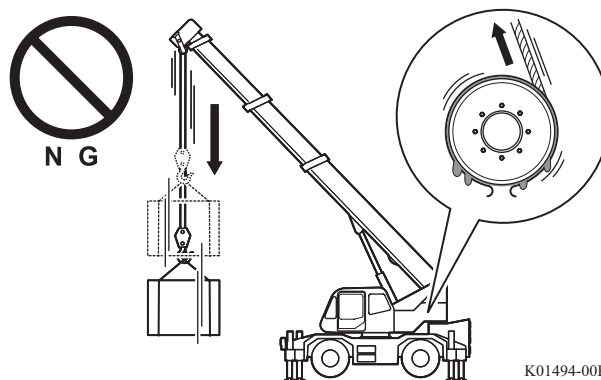

- **Remove the Battery Cable during Inspection and Maintenance of the Electrical System**

If you perform inspection and maintenance of the electrical system with battery cables connected, the wiring can short-circuit and damage the electrical and electronic equipment.

Before you perform inspection and maintenance of the electrical system, disconnect the battery cable on the negative terminal side (ground side).

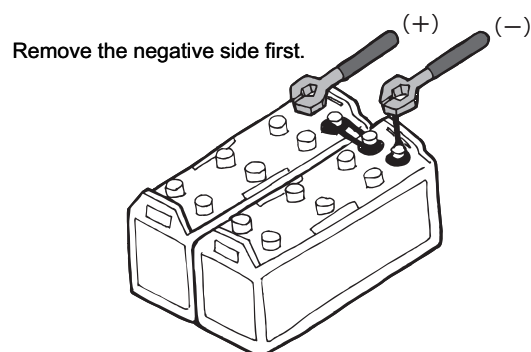

G61022-00E

- **Use Genuine Parts**

Use of non-genuine parts can pose a risk of causing troubles regarding safety and function.

When you replace parts such as a filter, use designated genuine parts.

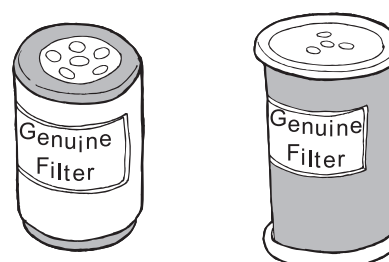

G61023-00E

- **Use Designated Oils and Greases**

Equipment can be adversely affected if oils or greases of brand and grade other than designated are used, or oils and greases of different brands are mixed.

When you replenish or replace oils or greases, use the designated oils and greases only. If you replace oils or greases with a different brand, replace entire amount of them.

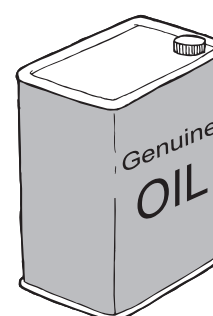

G61024-00E

- **Replace the Periodic Replacement Parts**

If you do not replace the periodic replacement parts as specified, an accident can occur. Observe the replacement intervals, and replace them periodically.

• Check after Maintenance

If you neglect the operational checks after maintenance, it can delay the discovery of oil leakage or malfunction. This can cause an accident.

After a maintenance work, check that the operation of the components where maintenance has been performed is normal, there is no oil leakage, and no bolts are left untightened.

Note that the maintenance does not end until you confirm that the machine operates properly.

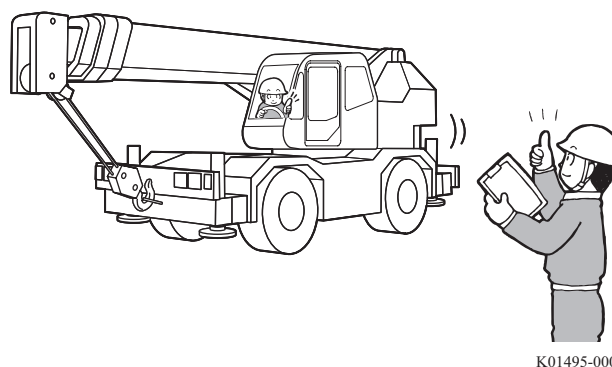

K01495-000

• Disposing of Waste

Improper disposal of waste, such as waste oil from the machine and used filter, pollutes the environment.

When you drain waste oil from the machine, collect it in a container. Do not pour the waste oil on the ground, or do not discharge it into a river or pond.

When you dispose of the waste oil, fuel, coolant, brake fluid, solvent, filters, batteries or other toxic substances, request an industrial waste disposal contractor for their disposal.

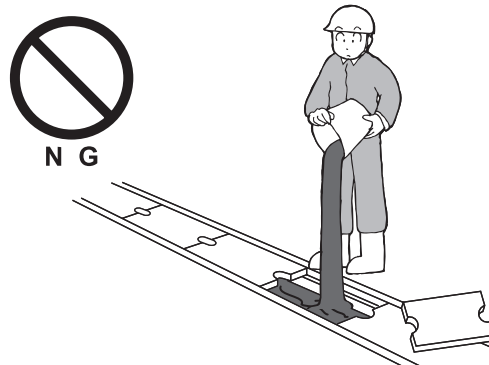

G61027-00E

• Never Release Fluorocarbons into Atmosphere

In order to protect the global environment, observe the precautions below.

- (1) Do not emit the refrigerants (fluorocarbons) enclosed in these products.
- (2) Collect the refrigerants (fluorocarbons) enclosed in these products when disposing of these products.

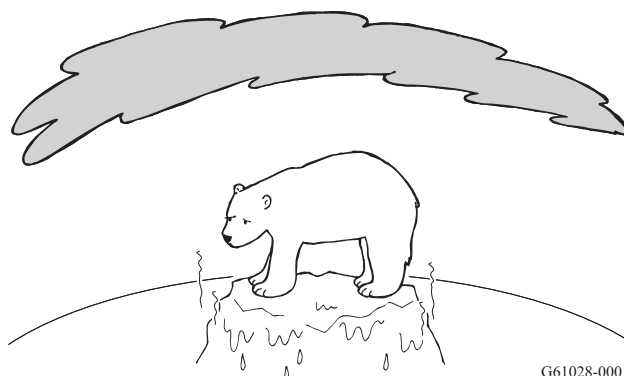

G61028-000

Inspection and Maintenance

About Inspection and Maintenance

NOTICE

- **The indicated inspection and maintenance frequency assumes a normal operating condition. If severe use (severe condition) is applicable, shorten the inspection and maintenance intervals accordingly.**
- **If you cannot perform inspection and maintenance by yourself, contact your nearest TADANO distributor or dealer for inspection and maintenance.**

Proper inspection and maintenance ensure a safe operation, and extend the service life of the machine. In order to make full use of the machine performance, carry out inspection and maintenance at the specified intervals to prevent failure and detect any potential failure at the earliest possible time.

1. Replacement of important periodic replacement parts (Periodic replacement part [page 319])
To ensure the safety of crane operations, periodic replacement of those parts is mandatory.
2. Ordinary periodic replacement parts (Refer to page 319.)
The replacement of those parts at regular intervals is recommended. For some of the ordinary periodic replacement parts, different replacement intervals are applicable if conditions of severe use (page 318) apply.
3. Inspection and maintenance items for carrier (Refer to page 322.)
Those inspection and maintenance items for the carrier are required to ensure the safety of crane operations. The following inspections are included.
 - Daily inspection (before travelling)
 - Monthly inspection
 - Quarterly inspection
 - Yearly inspection
 - Others such as overhauling that are needed depending on the parts.
 Different inspection and maintenance items are applicable if conditions of severe use (page 318) apply.
4. Inspection and maintenance items for crane (Refer to page 328.)
Those inspection and maintenance items for the crane are required to ensure the safety of crane operations. The following inspections are included.
 - Daily inspection (pre-operational inspection)
 - Monthly (or shorter period) inspection
 - Yearly (or shorter period) inspection
 - Others such as overhauling that are needed depending on the parts.
 Different inspection and maintenance items are applicable if conditions of severe use (page 318) apply.

Perform inspection and maintenance based on the time displayed on the hour meter or the specified interval, whichever comes first.

Standard time for inspection and maintenance assumes that 100 working hours corresponding to 1 month. Intervals described in this manual assume that the machine is used under normal operating conditions. Correctly perform inspection and maintenance at every specified time.

Under Severe Use (Severe Condition)

If the machine is used under severe conditions which are considerably different from standard use, the components can deteriorate remarkably earlier. In this case, it is necessary to carry out inspection and maintenance at the time earlier than the standard periods.

To keep machines that are routinely used under severe conditions always in good condition, perform the inspection and maintenance which TADANO recommends apart from the periodic inspections.

Conditions of Severe Use

If any one of the following conditions is satisfied, "severe use" is applicable.

Carrier

- A: Traveling distance on rough roads (such as an uneven road, gravel road, unpaved road) or snow-covered roads, or in dusty zones is 15% or more of the whole traveling distance.
- B: Traveling distance is long (Criterion: 621 miles {1,000 km} /per month) or over.
- C: Traveling distance on mountainous roads, uphill and downhill is 15% or more of the whole traveling distance.
- D: Starts and stops are frequently repeated, or low-speed traveling distance is 15% or more of the whole traveling distance.
- E: Traveling with a weight that exceeds the road traveling vehicle condition on the roads other than public roads is 15% or more of the whole traveling distance, or traveling at a speed exceeding the recommended speed for the weight.

Crane

- A: Loads of full lifting capacity are lifted often, but usually the loads are heavier than half of the lifting capacity.
(Usually, lifting loads of 50% to 80% of the lifting capacity)
- B: Usually lifting the lifting capacity.
(Usually, lifting loads of 80% or more of the lifting capacity)
- C: Using a crane equipped with a bucket, grapple, and magnet, or using for general stevedoring such as carrying containers and tetrapods.

Periodic Replacement Part

⚠ WARNING

If periodic parts replacement is neglected, a failure of the machine or a serious accident can occur. Replace the periodic replacement parts in accordance with the specified inspection criteria and at the specified intervals.

Some component parts of your machine deteriorate over time. Even without any visible wear, such parts must be replaced periodically to ensure safety.

The following tables give recommended/required replacement intervals for the two types of such parts:

- Important periodic replacement parts, for which periodic replacement is required to ensure the safety of crane operations.
- Ordinary periodic replacement parts, for which periodic replacement is recommended.

The replacement intervals are either based on the hourmeter reading or months/years.

Replace the parts according to the intervals whichever comes first.

If local laws and regulations specify shorter replacement intervals, observe them.

Contact your nearest TADANO distributor or dealer to have these parts replaced at the periodic intervals.

• Important periodic replacement parts

Replace the parts in the tables below according to the specified replacement intervals.

The indicated replacement intervals are requirements.

Important periodic replacement parts		Replacement interval (required)
ELECTRONIC PARTS	Control release switches	4 years or 4,800 hours
	Detect switches (for safety devices)	
	Operation detect switches	
	Position sensors	8 years or 9,600 hours
	Load sensors	
STEERING SYSTEM	Hoses for steering	2 years
	Packings, O-rings for steering cylinders	
	Packings, O-rings for steering circuit	
BRAKE SYSTEM	Brake hoses	2 years
	Seals, O-rings, cups for brake valves	1 year
	Seals, O-rings, cups for air boosters	
	Piston seals, dust seals for brake calipers	
	Rubbers, packings for brake air system	
ENGINE	Fuel hoses	2 years
	Hoses for coolant	4 years
AIR PRESSURE SYSTEM	Desiccant for air drier	1 year
OTHERS	Hoses for air compressor	2 years
	Hydraulic hoses for driving	4 years
	Switch for stop lamp	2 years
	Safety valves	
	Electronic valves	4 years
	Parking detect switches	2 years
	Hoses for suspension lock	4 years

Important periodic replacement parts(Oil,Filter)		Replacement interval (required)	First replacement
STEERING SYSTEM	Steering filter element	1 year or 1,200 hours	
BRAKE SYSTEM	Brake fluid	1 year or 1,200 hours	
POWERTRAIN SYSTEM	Transmission oil	1 year or 1,200 hours	1 month (100 hours)
	Transmission filter element		
	Differential oil	2 years or 2,400 hours	
	Axle wheel hub planetary gear oil		
ENGINE	Engine oil	500 hours	
	Oil filter element	500 hours	
	Air cleaner element	1 year or 1,200 hours	
	Fuel filter	500 hours	
	Long life coolant	2 years or 2,400 hours	
SWING SYSTEM	Gear oil for reducer	1 year or 1,200 hours	
HYDRAULIC OIL TANK	Oil	4 years or 4,800 hours	
	Oil filter	1 year or 1,200 hours	
	Air breather cap	6 months or 600 hours	
	Line filter	2 years or 2,400 hours	

•Ordinary periodic replacement parts

Replace the parts in the table below as required according to the check results.

The indicated replacement intervals are guidelines.

Ordinary periodic replacement parts			Replacement interval (guideline)	
HYDRAULIC EQUIPMENT	Seals for safety valves, operation valves, proportion valves, electronic valves		4 years or 4,800 hours	
	Packings for swivel joints		4 years or 4,800 hours	
		Severe condition	2 years or 2,400 hours	
	Seals for hydraulic motors, pumps, reducers		5 years or 6,000 hours	
	Hydraulic cylinders	Packings	5 years or 6,000 hours	
		Severe condition	2 years or 2,400 hours	
	Hydraulic hoses	General		5 years or 6,000 hours
		In outriggers		4 years or 4,800 hours
		For hose reels, packings		
		In the boom, for winch		4 years or 4,800 hours
		Severe condition	2 years or 2,400 hours	
BOOM(JIB)PARTS	Sheaves for hoisting		4 years or 4,800 hours	
	Sheaves for telescoping		4 years or 4,800 hours	
		Severe condition	2 years or 2,400 hours	
	Slide plates for boom		4 years or 4,800 hours	
		Severe condition	2 years or 2,400 hours	
	Electronic cable		5 years or 6,000 hours	
Wire rope for telescoping (*)		10 years		
WINCH PARTS	Winch wire rope		Depending on wire exchange standard	
	Wire stopper bolts and hook collars		3 years or 3,600 hours	
ELECTRONIC PARTS	Cord for Anti-Two block cord reel		2 years or 2,400 hours	
		Severe condition	1 years or 1,200 hours	
	Operation switches		4 years or 4,800 hours	
	Detection switches			
	Twoblocking detection switch		3 years or 3,600 hours	
Swivel joint brushes		4 years or 4,800 hours		
OTHER PARTS	WARNING, CAUTION, and DANGER name plates		Depending on check result	

(*):If proper rope tension cannot be maintained by adjustment any more, or any damage or wear is found, replace the rope.

Inspection and Maintenance Interval (Carrier)

The following table describes the daily (before traveling), monthly, quarterly and annual inspection and maintenance items.

This manual describes the procedures for daily inspection (before traveling) to be conducted by users. Perform the inspection before operating the machine. For the inspection procedures, refer to "Inspection before Traveling" (page 332).

○: TADANO designated inspection period

◇: TADANO designated severe condition.

Inspection and maintenance item		Inspection and maintenance interval				Remarks	
		Inspection	Daily	Monthly	Quarterly		Yearly
Components	Inspection item						
Steering system	Steering wheel	Operating condition			○	○	
		Play, looseness			○	○	
		Inspection of operation force			○	○	
	Gear box (Orbitrol)	Oil leakage			○	○	
		Looseness of mounting			○	○	
		Looseness of bearing				○	
	Rods and arms	Looseness, vibration and damage				○	
		Crack and damage of dust boots for ball joint				○	
		Bend of tie rod			○	○	
	Knuckle	Looseness in connecting part (Knuckle and king pin)		◇	○	○	
		Looseness in connecting part (Knuckle and vertical directions of axle)		◇	○	○	
		Crack				○	
	Steered wheel	Wheel alignment				○	
		Right and left turning angle				○	
	Power steering device	Oil leakage and amount of oil (Piping, hose, joint, pump, valve, cylinder)			○	○	
		Looseness of mounting (Pump, valve)			○	○	
		Looseness in steering cylinder connecting part				○	
		Crack and damage on steering cylinder dust boots				○	
		Damage and wear on steering cylinder rod and internal surface of the cylinder			Every 2 years		Overhaul before inspection
		Function of steering solenoid valve			○	○	
Steering pump, volume control valve functional check				Every 2 years			

Inspection and maintenance item		Inspection and maintenance interval				Remarks	
		Inspection	Daily	Monthly	Quarterly		Yearly
Components	Inspection item						
Brake system	Brake pedal	Depressing stroke	<input type="radio"/>				
		Play and clearance to floor when pedal is depressed		◇		<input type="radio"/>	
		Braking condition	<input type="radio"/>			<input type="radio"/>	<input type="radio"/>
	Hose and pipe	Leakage, damage and mounting status			<input type="radio"/>	<input type="radio"/>	
	Reservoir tank	Electrolyte level	<input type="radio"/>		<input type="radio"/>	<input type="radio"/>	
	Master cylinder, wheel cylinder, disc caliper	Liquid leakage from caliper				<input type="radio"/>	
		Function, wear, damage				<input type="radio"/>	
		Disassembly, inspection, and maintenance of caliper				<input type="radio"/>	
	Brake valve, quick release valve, relay valve	Function			<input type="radio"/>	<input type="radio"/>	
		Air pressure rising condition	<input type="radio"/>				
		Exhaust sound from brake valve	<input type="radio"/>				
		Air leakage from brake valve			<input type="radio"/>	<input type="radio"/>	
		Function of check valve and relay valve				<input type="radio"/>	
	Brake disc and pads	Clearance between brake disc and pads				<input type="radio"/>	
		Pad wear				<input type="radio"/>	
		Wear and damage of brake disc				<input type="radio"/>	
	Air booster	Function				<input type="radio"/>	
		Oil tightness and air tightness of air booster				<input type="radio"/>	
		Disassembly, inspection, and maintenance of brake valve and air booster				<input type="radio"/>	
	Parking brake mechanism	Braking condition	<input type="radio"/>		<input type="radio"/>	<input type="radio"/>	
	Center brake disc and pads	Looseness in the mounting of disc				<input type="radio"/>	
		Clearance between brake disc and pads				<input type="radio"/>	
		Pad wear				<input type="radio"/>	
		Wear and damage of brake disc				<input type="radio"/>	
		Wear of cam roller guide				<input type="radio"/>	
		Looseness and vibration in chamber mounting			<input type="radio"/>	<input type="radio"/>	
		Air leakage from chamber				<input type="radio"/>	
Disassembly, inspection, and maintenance of chamber				<input type="radio"/>			
Exhaust brake	Function			<input type="radio"/>	<input type="radio"/>		

Inspection and maintenance item		Inspection and maintenance interval				Remarks		
		inspection	Daily	Monthly	Quarterly		Yearly	
Components	Inspection item							
Traveling system	Tire	Air pressure in tires	<input type="radio"/>					
		Crack and damage	<input type="radio"/>					
		Unusual wear	<input type="radio"/>					
		Depth of groove	<input type="radio"/>					
	Wheel	Mounting state of disc wheel	<input type="radio"/>			<input type="radio"/>		
		Tire condition				<input type="radio"/>		
		Looseness and damage of wheel nut and wheel bolt			◇	<input type="radio"/>	<input type="radio"/>	
		Vibration in front wheel bearing				<input type="radio"/>		
		Damage of rim, side ring, and disc wheel				<input type="radio"/>		
		Looseness in rear wheel bearing				<input type="radio"/>		
Tire rotation				Every 3,107 miles (5,000 km)				
Axle housing	Crack, damage, and deformation of axle				<input type="radio"/>			
Suspension system	Hydraulic suspension	Looseness and damage of mounting part of torque rods and lateral rods		◇	<input type="radio"/>	<input type="radio"/>		
		Looseness of mounting part of lateral rod support			<input type="radio"/>	<input type="radio"/>		
		Looseness in rotating parts of torque rods and lateral rods				<input type="radio"/>		
		Oil leakage in suspension cylinder and accumulator pilot check valve	<input type="radio"/>			<input type="radio"/>	<input type="radio"/>	
		Looseness in suspension cylinder mounting part			<input type="radio"/>	<input type="radio"/>		
		Crack and damage of hydraulic suspension cylinder dust boots				<input type="radio"/>		
		Gas pressure in accumulator				<input type="radio"/>		
		Function of pilot check valve			<input type="radio"/>	<input type="radio"/>		

Inspection and maintenance item		Inspection and maintenance interval				Remarks	
		inspection	Daily	Monthly	Quarterly		Yearly
Components	Inspection item						
Power transmission system	Transmission and torque converter	Mounting condition, oil leakage and oil level, soiling	○	◇	○	○	
		Looseness in transmission operating mechanism					
		Operation of transmission mechanism			○	○	
		Check and washing of strainer				○	First inspection: 1 month
		Crack and damage of hose				○	
		Clutch oil pressure				○	
	Propeller shaft	Looseness in connecting part		◇	○	○	
		Looseness in coupling				○	
		Propeller shaft runout				○	
		Greasing			○	○	
	Axle shaft	Looseness in connecting part		◇	○	○	
		Crack and damage of universal coupling dust boots				○	
		Looseness in coupling				○	
		Greasing			○	○	
	Axle, differential	Oil leakage and oil level			○	○	
	Axle, hub	Greasing on hub bearing and axle shaft spline			Every 2 years or 14,913 miles (24,000 km)		
		Oil leakage and oil level			○	○	
Electrical system	Battery	Electrolyte level	○		○	○	
		Terminal connection condition			○	○	
		Specific gravity of electrolyte				○	
	Electric wiring	Looseness and damage of connecting parts			○	○	
	Starting unit	Engagement of pinion				○	
	Charging unit	Charging function			○	○	

Inspection and maintenance item		Inspection and maintenance interval				Remarks		
		Inspection	Daily	Monthly	Quarterly		Yearly	
Components	Inspection item							
Engine	Main unit	Start-up, abnormal noise	○					
		Air cleaner element condition	○	◇	○	○	Perform daily inspection by the dust indicator.	
		Conditions in low speed and acceleration	○			○	○	
		Exhaust condition				○	○	
		Tightening status of each part of cylinder head and manifold					○	
		Compression pressure			Perform inspection when abnormality exists in start-up, low speed, acceleration, and exhaust condition.			
		Valve clearance						
	Lubrication unit	Oil level	○			○	○	
		Oil leakage			◇	○	○	
	Fuel unit	Fuel Leakage	○			○	○	
		Injection pressure and injection condition of injection nozzle			Perform inspection when abnormality exists in start-up, low speed, acceleration, and exhaust condition.			
		Injection timing and injection amount						
		Function of feed pump						
		Inspection and cleaning of strainer						
		Cleaning of fuel tank			Refer to "Fuel System" (page 386)			
		Water level in the water separator, water drainage	○					
	Cooling unit	Coolant level	○					
		Looseness, tension, and damage of fan belt	○	◇	○	○		
		Water leakage, looseness of hose band				○	○	
		Damage and mounting condition of coolant hose				○	○	
		Mounting condition and function of radiator cap				○	○	
		Clogging and cleaning of radiator fins				○	○	Clean every 500 hours
	Others	Mounting condition of engine mount					○	
	Lighting device and turn signal	Lighting and flashing condition, soiling and damage	○			○	○	
	Reflector, license plate	Soiling, damage, and mounting condition	○					
	Horn, wiper, windshield washer pump, defroster, and locking device	Washer liquid level and spraying condition	○				○	
		Wiping condition	○				○	
Rear-view mirror (including electric type) and reflector	Operation					○		
	Reflecting condition, operation	○						

Inspection and maintenance item		Inspection and maintenance interval				Remarks
		inspection	Daily	Monthly	Quarterly	
Components	Inspection item					
Exhaust pipe and muffler	Looseness and damage of mounting part			○	○	
	Function				○	
Air compressor	Water condensation in air tank	○		○	○	
	Function of compressor, pressure regulator, and unloader valve				○	
	Function of air dryer			○	○	
Meters and Gauges	Operation				○	
Chassis frame and body	Looseness and damage			○	○	
	Function of door lock					
Others	Abnormality found in previous driving	○				
	Lubrication condition of each part of chassis		◇	○	○	
Sound insulation plate and acoustic material	Mounting condition and damage of the sound insulation plate, etc.				○	

Inspection and Maintenance Interval (Crane)

The following table describes the maintenance items for the daily (pre-operational) inspection and periodic in-house inspection (every month or earlier; every year or earlier).

The following table describes the maintenance items for the daily (pre-operational) inspection and in-house inspection to be conducted by users. Carry out the inspection before operating the machine. For the inspection procedure, refer to "Pre-operational Inspection" (page 351).

○: TADANO designated inspection

◇: TADANO designated severe condition.

(*1): Overhaul every 4800 hours or 4 years. Overhaul every 2400 hours or 2 years if the crane is used for foundation work or stevedoring. Remove the dust in the boom with an air blow as necessary if the crane is used in a place with a large amount of dust such as sandblasting.

(*2): Apply proper tension at periodic inspection.

Inspection and maintenance item		Inspection and maintenance interval			Remarks	
		Daily inspection	Every month or earlier	Every year or earlier		
Components	Inspection item					
Hydraulic pressure generating system	PTO system	Operation, oil leakage	○	○	○	
		Mounting, damage, heat generation, abnormal noise		○	○	
	Piping, hose	Oil leakage, deterioration	○	○	○	
		Mounting status, abnormal vibration, heat generation, abnormal noise		○	○	
	Hydraulic oil tank	Oil level	○	○	○	
		Mounting, crack, contamination, oil leakage		○	○	
		Clogging and contamination of air breather		○	○	
	Filter, case	Clogging, oil leakage, damage		○	○	
	Hydraulic pump	Operation, oil leakage	○	○	○	
		Mounting, looseness, crack, damage		○	○	
	Center joint	Mounting, looseness, leakage (oil, water, air), abnormal noise, greasing		○	○	
	Control valve	Oil leakage	○	○	○	
		Mounting, operation, looseness		○	○	
	Oil cooler	Mounting, motor operation, looseness, oil leakage, damage, abnormal noise		○	○	
Outrigger system	Inner case, outer case	Mounting, damage	○	○	○	
		Operation, bend, crack, dent		○	○	
		Damage, wear, breakage, deformation of outrigger structure, abnormal noise		◇		
		Welded structural parts		◇		
		Important structure mounting parts (pin, bolt, etc.)		◇		
	Jack cylinder (including holding valve)	Operation, oil leakage, spontaneous lowering	○	○	○	
		Mounting, looseness, damage, spontaneous retraction		○	○	

Inspection and maintenance item		Inspection and maintenance interval			Remarks	
		Daily inspection	Every month or earlier	Every year or earlier		
Components	Inspection item					
Outrigger system	Slider (including lock pin)	Operation, oil leakage	<input type="radio"/>	<input type="radio"/>	<input type="radio"/>	
		Mounting, operation, damage, looseness, oil leakage		<input type="radio"/>	<input type="radio"/>	
	Extension width detector	Mounting, operation (reel, switch), accuracy, reel winding condition, damage		<input type="radio"/>	<input type="radio"/>	
	Control valve	Mounting, operation, oil leakage		<input type="radio"/>	<input type="radio"/>	
	Control box	Mounting, operation, damage, stained or peeled nameplate		<input type="radio"/>	<input type="radio"/>	
	Level	State of bubble	<input type="radio"/>	<input type="radio"/>	<input type="radio"/>	
		Mounting, soiling, damage		<input type="radio"/>	<input type="radio"/>	
	Outrigger status indicator symbol	Indication state	<input type="radio"/>	<input type="radio"/>	<input type="radio"/>	
	Float	Mounting, crack, deformation, soiling, lubrication		<input type="radio"/>	<input type="radio"/>	
Piping, hose	Mounting, looseness, crack, oil leakage, damage, deterioration		<input type="radio"/>	<input type="radio"/>		
Swing system	Swing frame	Crack, deformation, damage		<input type="radio"/>	<input type="radio"/>	
		Damage, wear, breakage, deformation, abnormal noise of swing frame structure		<input type="checkbox"/>		
		Welded structural parts		<input type="checkbox"/>		
		Important structure mounting parts (pin, bolt, etc.)		<input type="checkbox"/>		
	Swing bearing	Operation, looseness, lubrication		<input type="radio"/>	<input type="radio"/>	
		Abnormalities of mounting bolts (inner ring, outer ring)/looseness, elongation, rust, breakage, detachment		<input type="radio"/>	<input type="radio"/>	
	Swing speed reducer, swing motor, rotary joint	Operation, oil leakage	<input type="radio"/>	<input type="radio"/>	<input type="radio"/>	
		Mounting, looseness, crack, soiling, damage, oil level		<input type="radio"/>	<input type="radio"/>	
	Swing brake	Braking performance, oil leakage	<input type="radio"/>	<input type="radio"/>	<input type="radio"/>	
	Hydraulic pump	Operation, oil leakage	<input type="radio"/>	<input type="radio"/>	<input type="radio"/>	
		Mounting, looseness, crack, damage		<input type="radio"/>	<input type="radio"/>	
	Swing lock system	Mounting, operation, crack, damage		<input type="radio"/>	<input type="radio"/>	
Piping, hose	Mounting, looseness, crack, oil leakage, damage, deterioration		<input type="radio"/>	<input type="radio"/>		

Inspection and maintenance item		Inspection and maintenance interval			Remarks	
		Daily inspection	Every month or earlier	Every year or earlier		
Components	Inspection item					
Boom telescoping/elevating system	Boom	Mounting, crack, deformation, damage	○	○	○	(*1)
		Wear on pad, lubrication, wear on pivot		○	○	
		Damage, wear, breakage, deformation, abnormal noise of boom structure		◇		
		Welded structural parts		◇		
		Important structure mounting parts (pin, bolt, etc.)		◇		
	Single top (including boom head)	Mounting, crack, deformation, damage	○	○	○	
		Wear, lubrication		○	○	
	Telescoping cylinder (including holding valve)	Mounting, operation, looseness, oil leakage, spontaneous retraction	○	○	○	
	Boom elevating cylinder (including holding valve)	Mounting, operation, looseness, oil leakage, spontaneous retraction	○	○	○	
		Wear on pivot pin, lubrication		○	○	
Telescoping wire rope	Telescoping, synchronization, wear, damage, corrosion, cut wire		○	○	(*2)	
Sheave	Mounting, operation, deformation, damage, wear		○	○		
Telescoping hose in boom	Mounting, elongation, crack, damage, deterioration		○	○	(*2)	
Jib system	Jib	Mounting, crack, deformation, damage	○	○	○	
		Installing and stowing status, lubrication, wear on pivot		○	○	
		Damage, wear, breakage, deformation, abnormal noise on jib structural parts		◇		
		Welded structural parts		◇		
	Important structure mounting parts (pin, bolt, etc.)		◇			
Sheave	Mounting, operation, deformation, damage, wear		○	○		
Winch	Winch drive unit, winch drum	Mounting, operation, crack, oil leakage, damage, abnormal noise	○	○	○	
		Looseness, soiling, oil level, wire rope winding status, wire rope mounting, looseness in drum bearing		○	○	
	Winch brake	Oil leakage	○	○	○	
		Operation, brake performance		○	○	
	Wire Rope	Mounting status of rope socket, disorderly winding, wear, damage, condition of places where wire ropes pass through	○	○	○	
		Corrosion, deformation, cut wire, lubrication	○	○	○	
Piping, hose	Mounting, looseness, crack, oil leakage, damage, deterioration		○	○		

Inspection and maintenance item		Inspection and maintenance interval			Remarks	
		Daily inspection	Every month or earlier	Every year or earlier		
Components		Inspection item				
Hook block	Main hook block (including attachments)	Mounting, damage	<input type="radio"/>	<input type="radio"/>	<input type="radio"/>	
		Operation, crack, deformation, wear, lubrication		<input type="radio"/>	<input type="radio"/>	
	Auxiliary hook block	Mounting, damage	<input type="radio"/>	<input type="radio"/>	<input type="radio"/>	
		Operation, crack, deformation, wear, lubrication		<input type="radio"/>	<input type="radio"/>	
Safety devices	Load moment indicator (AML)	Operation, pre-operational inspection	<input type="radio"/>	<input type="radio"/>	<input type="radio"/>	
		Mounting, indication, soiling, damage, indication status		<input type="radio"/>	<input type="radio"/>	
	Boom angle detector	Mounting, accuracy, oil leakage, damage		<input type="radio"/>	<input type="radio"/>	
	Boom length detector	Mounting, accuracy, damage, cable winding status		<input type="radio"/>	<input type="radio"/>	
	Moment detector	Accuracy, damage		<input type="radio"/>	<input type="radio"/>	
	Swing angle (position) detector	Mounting, accuracy, damage		<input type="radio"/>	<input type="radio"/>	
	Anti-twoblock device (weight, lifting rope)	Operation (stop, alarm, etc.)	<input type="radio"/>	<input type="radio"/>	<input type="radio"/>	
		Mounting, damage		<input type="radio"/>	<input type="radio"/>	
	External indicator lamp	Mounting, operation, damage		<input type="radio"/>	<input type="radio"/>	
	Piping, hose	Mounting, looseness, crack, oil leakage, damage, deterioration		<input type="radio"/>	<input type="radio"/>	
	Other Safety Devices	Mounting, operation, damage		<input type="radio"/>	<input type="radio"/>	
	Anemometer (Option)	Operation	<input type="radio"/>	<input type="radio"/>	<input type="radio"/>	
		Mounting, damage		<input type="radio"/>	<input type="radio"/>	
Work lamp	Operation	<input type="radio"/>	<input type="radio"/>	<input type="radio"/>		
Steps and rails	Mounting	<input type="radio"/>	<input type="radio"/>	<input type="radio"/>		
Control system	Levers, switches	Operation	<input type="radio"/>	<input type="radio"/>	<input type="radio"/>	
		Mounting, damage, lubrication		<input type="radio"/>	<input type="radio"/>	
	Heater, air conditioner	Operation		<input type="radio"/>	<input type="radio"/>	
	Drum Indicator	Mounting, operation, deformation, damage		<input type="radio"/>	<input type="radio"/>	
	Meters and gauges	Mounting, operation, indication, soiling, damage		<input type="radio"/>	<input type="radio"/>	
	Lighting, horn	Mounting, operation, lens breakage, soaking		<input type="radio"/>	<input type="radio"/>	
	Nameplates	Soiling, damage, color deterioration		<input type="radio"/>	<input type="radio"/>	
Piping, hose	Mounting, looseness, crack, oil leakage, damage, deterioration		<input type="radio"/>	<input type="radio"/>		
Frame	Chassis frame	Damage, wear, breakage, deformation, abnormal noise on chassis frame structure		<input type="checkbox"/>		
		Welded structural parts		<input type="checkbox"/>		
		Important structure mounting parts (pin, bolt, etc.)		<input type="checkbox"/>		
Test	Load test	Test load lbs, Load radius ft.			<input type="radio"/>	
		Test load lbs, Load radius ft.			<input type="radio"/>	
	Comprehensive test	Operating speed, abnormal noise, abnormal vibration, abnormal heat generation		<input type="radio"/>	<input type="radio"/>	

Inspection before Traveling

⚠ WARNING

If inspection before traveling is neglected, it is impossible to find problems in their early stages and it can result in accidents.

Conduct the inspection before traveling, and take corrective action immediately if any abnormality is found.

Check the items below in the inspection before traveling.

If you find any abnormality, take corrective actions by yourself, or contact your nearest TADANO distributor or dealer for maintenance.

- Abnormal items detected on the previous day or operation
- Inspection around Carrier
 1. Water Condensation in Air Tank
 2. Soiling and Damage of Lamps and License Plates
 3. Fuel Leakage
 4. Oil Leaks from the Suspension Cylinder
 5. Oil Leaks from the Transmission, Oil Level
 6. Battery Electrolyte Level
 7. Brake Fluid Level
 8. Tire condition
- Inspection of the Engine Room
 1. Engine Oil Level, Contamination
 2. Coolant Level in the Radiator
 3. Looseness, Tension, and Damage of the Fan Belt
 4. Air Cleaner Check
- Inspection at Driver's Seat
 1. Engine Start-up, Abnormal Noise
 2. Condition in Engine Low Speed and Acceleration
 3. View from Mirror
 4. Check of Lamp Operation
 5. Washer Liquid Level, Spraying Condition
 6. Operation of Wipers
 7. Function of Foot Brake
 8. Function of Parking Brake

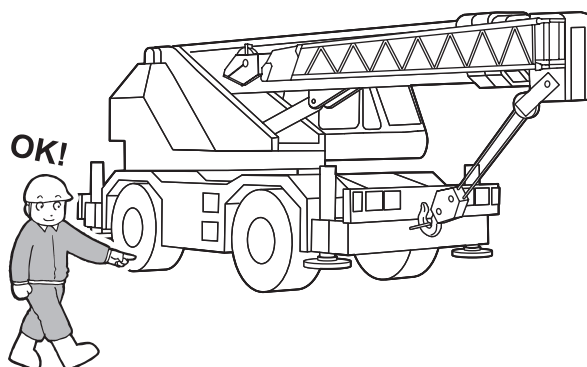

K01433-00J

Abnormal Items Detected On the Previous Day or Operation

Check for abnormality found on the previous day or previous traveling.

If you cannot perform necessary maintenance work by yourself, immediately contact your nearest TADANO distributor or dealer for maintenance.

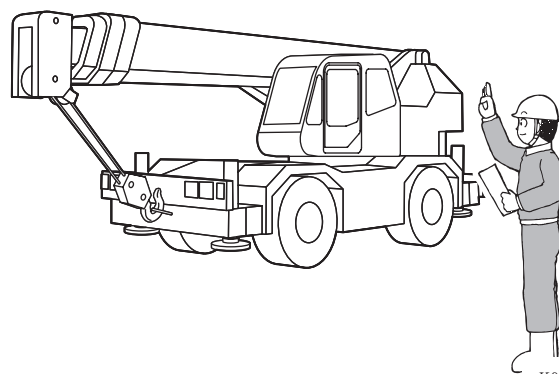

K01434-000

Inspection around Carrier

Water Condensation in Air Tank

Pull the drain cock lever of the air tank to drain water in the tank.

If a large amount of water is drained, deterioration of the air dryer function is suspected. This needs to be repaired.

- ☞ For Maintenance of the air dryer, refer to "Air Dryer" (page 390).
- ☞ The drain cocks for the air tank are located at two places on the right side of the upper swing table, and four places on the right side of the carrier.

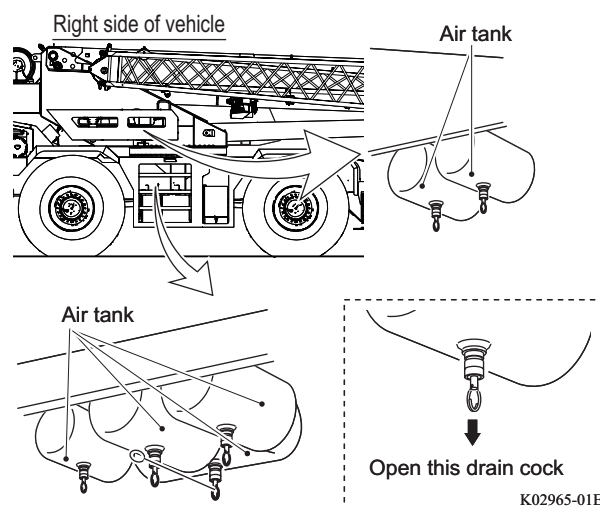

Soiling and Damage of Lamps and License Plates

1. Inspect the lamps and license plates for soiling and damage.
2. Check the lenses and reflectors of the lamps for any soiling, discoloration, or damage.
3. Clean them if soiled. Replace the components if damaged.

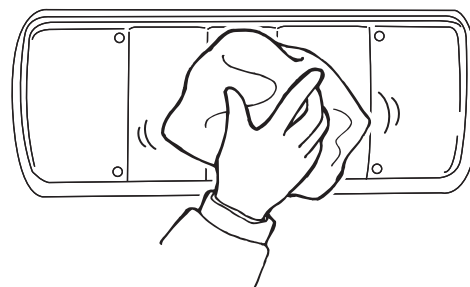

G63004-000

Fuel Leakage

⚠ WARNING

If there is any fuel leakage, never start the engine. It can cause a fire.

Check for a fuel leakage.

If a fuel leakage is found, have your nearest TADANO distributor or dealer inspect it.

Oil Leaks from Suspension Cylinder

Check for any oil leaks from the suspension cylinder.

If there is a oil leakage, contact your nearest TADANO distributor or dealer for inspection and maintenance.

Oil Leaks from the Transmission, Oil Level

Oil Leaks from the Transmission

Check for any oil leaks from the transmission.

If there is a oil leakage, contact your nearest TADANO distributor or dealer for inspection and maintenance.

Oil Level in the Transmission

CAUTION

The torque converter and transmission are very hot immediately after the operation, and you may suffer burns if you work on it. Let the torque converter and transmission cool down until they can be touched with your bare hands before starting maintenance work.

NOTICE

An excessively low or high oil level can cause the clutch to fail or overheat. Make sure that the oil level is in the specified range.

1. Extend the outriggers, and set up the machine horizontally.
2. Set the PTO switch to "OFF", the air conditioner to "OFF", the shift lever to "N", and then start the engine.
3. Operate the engine at an idling speed for several minutes, and raise the oil temperature approximately to 122°F (50°C).
 For oil temperature, refer to the pointer shown in the right illustration.

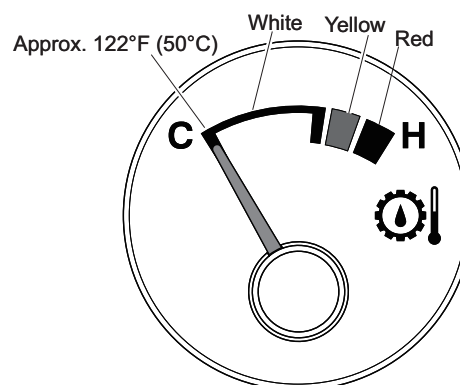

K01353-00E

4. Check that the oil level is stable. Then, check the oil level with the oil level gauge located on the transmission.

The specified oil level is between the "Hi" and "Low".

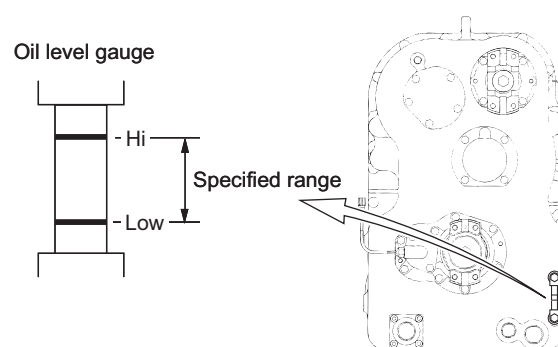

K04267-00E

Battery Electrolyte Level

⚠ WARNING

- The gas released from the battery is explosive. Do not use a match, cigarette lighter, or other open flame for illumination. The gas can catch a fire and explode. Use explosion-proof illuminating equipment when you check the battery electrolyte level.
- If battery electrolyte comes into your eyes, it can cause blindness. If this occurs, immediately flush your eyes with a large amount of water, and seek medical attention.
- Before removing the battery, turn the starter switch to the OFF position. Then, disconnect the cable from the ground (negative) terminal of the battery first, then the positive terminal. When connecting the cable, connect it to the positive terminal of the battery first, then to the ground terminal. Always be careful with the terminal connection.
- If you use or charge the battery when its electrolyte level is below the "LOWER LEVEL" line indicated on its side, it can cause an explosion of the battery. Always take a proper care of the battery electrolyte level.

1. Remove the battery cover.
2. Inspect that the battery electrolyte level is within the specified range.

 The electrolyte level should be between the "UPPER LEVEL" and "LOWER LEVEL" lines indicated on the side of the case.

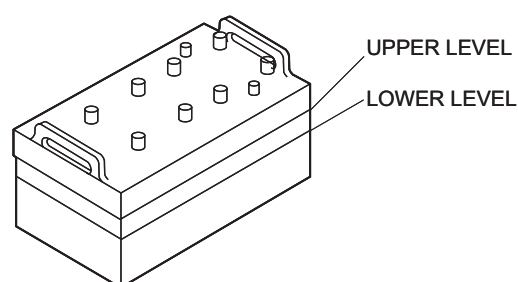

G63005-000

3. If the electrolyte level is below the "LOWER" line, refill the replenishment fluid or distilled water.

Brake Fluid Level

⚠ WARNING

- If the brake fluid decreases, the brakes can fail, resulting in an accident. If the fluid level is low, check the brake system for fluid leakage. If there is a brake fluid leakage, contact your nearest TADANO distributor or dealer for repair. If there is no leaks but the fluid level is low, the disc brake pads can be worn. Inspect the pads for excessive wear.
- "TADANO Genuine Brake Fluid" is a glycol-based fluid. If silicon- or mineral-based brake fluid is used, it permeates the packing, causing the brakes to become ineffective. Always use "TADANO Genuine Brake Fluid".

NOTICE

- Do not mix brake fluid of different brands together. Mixing of different brands of brake fluid together can change the properties of the fluid, and can have an adverse effect on the brake system. For brake fluid, use "TADANO Genuine Brake Fluid".
- Before removing the cap, clean the area around the cap.
- If any foreign matter is deposited in the brake fluid reservoir, contact your nearest TADANO distributor or dealer for inspection and maintenance.
- If the spilled brake fluid adheres to the coated surface, the coating can peel off. Wipe off the spilling immediately.
- The brake fluid has significant moisture absorbing properties. Use an unopened new brake fluid only for replenishment and replacement.

1. Check that the fluid level in the brake fluid reservoir is within the specified range.

 If the fluid level is between the "H" and "L" lines, the fluid amount is adequate.

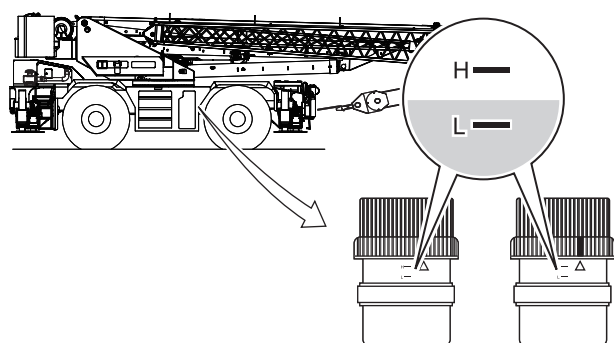

K07043-00E

2. If the brake fluid level is low, check for any fluid leakage in the piping system. Remove the cap on the brake fluid reservoir, and add brake fluid to "H" line.

NOTICE

Note that the fluid level exceeding the "H" line may cause the fluid leakage.

3. After adding, tighten the cap until the mark on the cap aligns with the mark on the tank.

Tire condition

⚠ WARNING

Check the tire air pressure before traveling when the tires are cold.
If the pressure is too high or low, the tires can be damaged or an accident can occur

Tire Air Pressure

1. Check the tire air pressure with an air gauge.
2. If the air pressure is not correct, adjust it to the specified pressure.
3. After measuring the pressure and inflating the tire, attach the valve cap.

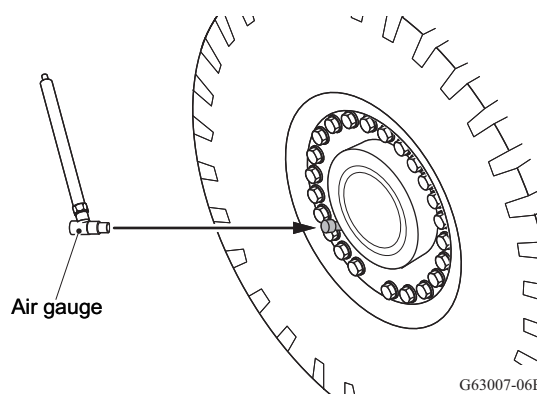

Looseness of Wheel Nut, Crack on Wheel

⚠ WARNING

If there is any crack on the wheel, do not travel. A serious accident can occur.

1. Tap the wheel nuts lightly with a hammer to check for looseness.
2. Inspect the wheels for cracks.
3. If there is any looseness or crack, take necessary measures.

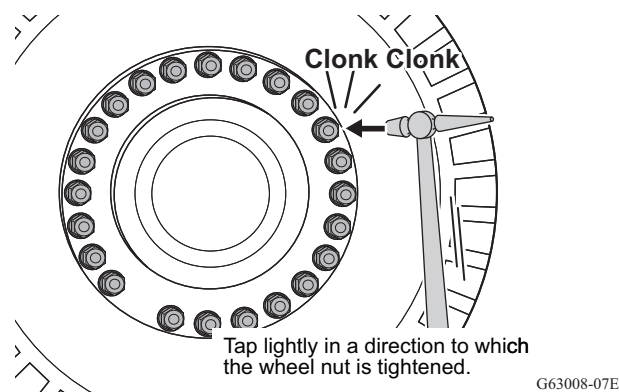

Crack, Damage on Tires

⚠ WARNING

Using tires that have significant crack or damage, or whose treads are worn out can cause the tires to skid or blow out, resulting in an accident. If a check reveals that a tire is unfit for use, replace it with a new tire immediately.

1. Check the entire tread and side walls for any cracks or damages.
2. Check the circumference of the tire for any nails, stones or other foreign matter stuck or caught.
3. If there are cracks or damages on a tire, replace it with a new one.

☞ For replacement of the tire, refer to "Tire, Wheel" (page 393).

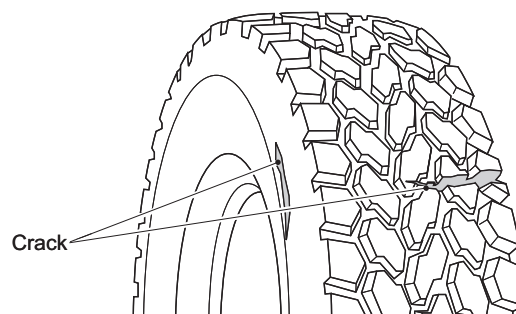

G63009-00E

Irregular Wear of Tire

1. Check the tread for irregular wear.
2. If there is any irregular wear, replace the tire with a new one, and eliminate the cause of the wear.

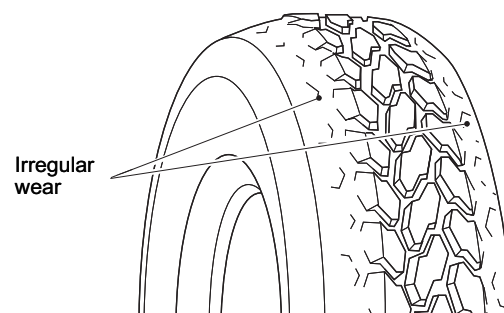

G63010-00E

Tire Tread Depth

1. Check that the tread remains sufficiently.

☞ When the remaining tread is less than the wear limit, the wear limit indicator (slip sign) appears at the slip sign indication position.

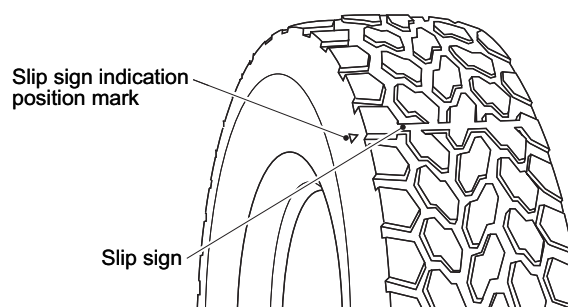

G63011-00E

2. When a slip sign appears, replace the tire with a new one.

Inspection of the Engine Room

Engine Oil Level, Contamination

⚠ WARNING

- Do not spill the engine oil when replenishing.
Engine oil adhering to the exhaust pipes can cause a fire.
Completely wipe off any spilled oil.
- When inspecting the oil level just after operation, the engine and piping are hot. Be careful not to suffer a burn.

NOTICE

Do not add engine oil beyond the specified level on the dipstick. Otherwise, it can cause an engine failure.

☞ Inspect the machine on a level ground before starting the engine. Oil level cannot be measured correctly if the machine is inclined or the engine is running.

1. Pull out the dipstick, and wipe off the oil on it using a cloth.

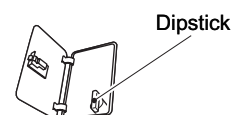
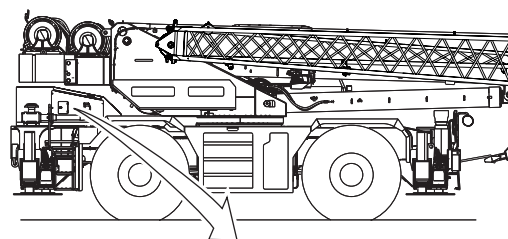

K07122-00E

2. Insert the dipstick to the original position, and then slowly pull it out.

☞ If the oil level mark is between "ADD" and "FULL" on the dipstick, the engine oil level is normal.

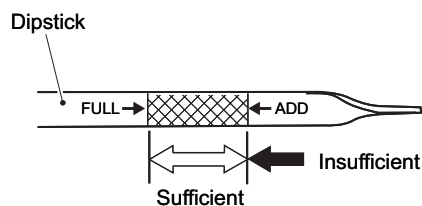

3. If the oil level is low, add oil through the oil filler.
If the oil is contaminated excessively, replace the engine oil.

G63013-01E

☞ Refer to the separate engine manual for how to add or replace the engine oil.



4. After inspection, insert the dipstick to the original position.

Coolant Level in the Radiator

⚠ WARNING

When the engine is warmed up to the normal operating temperature, the engine coolant is hot with high pressure. In this state, do not remove the radiator cap. If you open the cap carelessly, it causes hot water and steam to spout, causing burns.

Let the radiator cap cool down until it can be touched by bare hands before starting work.

G63014-00E

 Inspect the machine on level ground before starting the engine. You cannot measure the accurate coolant level on inclined ground or when the engine is running.

Check the coolant level from the check window.
The gauge is normally full with the coolant.
If the level is low, add coolant through the supply port.

If the surface is too low, check for leakage from the cooling system.

If the coolant level goes down quickly after refill, a leak from the cooling system is a likely cause. Contact a Tadano distributor or dealer for inspection.

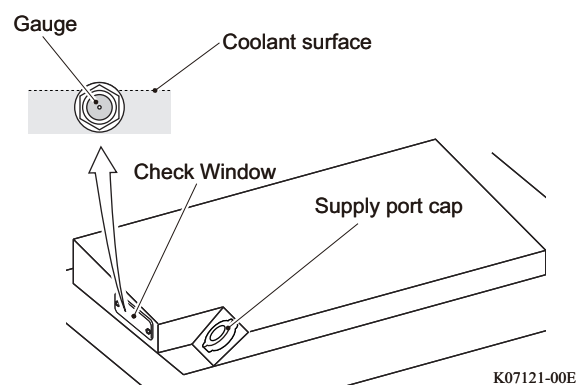

Looseness, Tension, and Damage of the Fan Belt

⚠ WARNING

Stop the engine before inspecting the fan belt. If you touch or come near to the rotating parts when the engine is running, your hands or clothing can be caught, resulting in an injury.

Check the fan belt for damage.

If it is damaged, replace it with a new one.

 To replace a fan belt, refer to the separate engine manual.

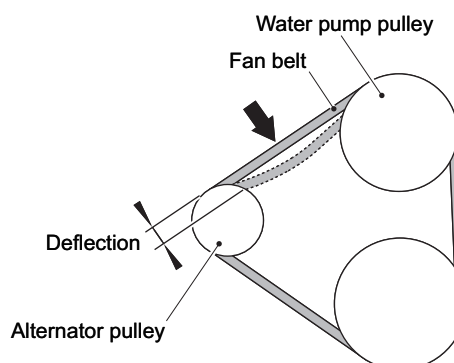

G63015-00E

Air Cleaner Check

Check the air cleaner by the dust indicator.

If the red signal is visible in the window, clean the element.

 To clean an element, refer to "Engine" (page 379).

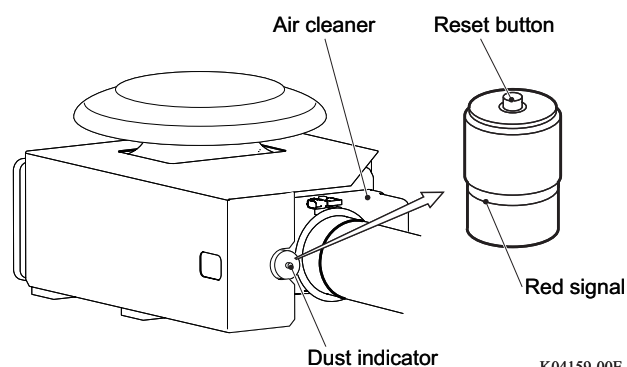

K04159-00E

Crankcase breather hose Check

Check whether there is any sludge or fragment, or any ice is made in the breather hose.

In a cold climate where icing is likely to occur, check inside of the breather hose frequently.

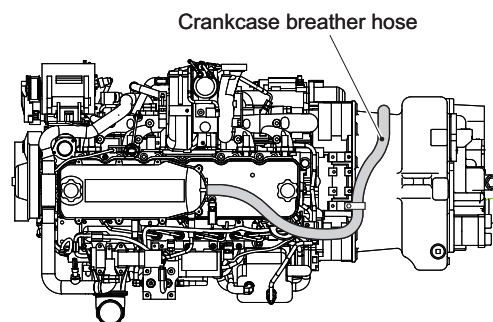

K04074-00E

Inspection at Driver's Seat

Engine Start-up, Abnormal Noise

Inspect that the engine starts up smoothly, and there is no abnormality in starting up.

Check for any abnormal noise at start-up and in the idling condition.

If the engine does not start up normally or there is some abnormal noise, contact your nearest TADANO distributor or dealer for maintenance.

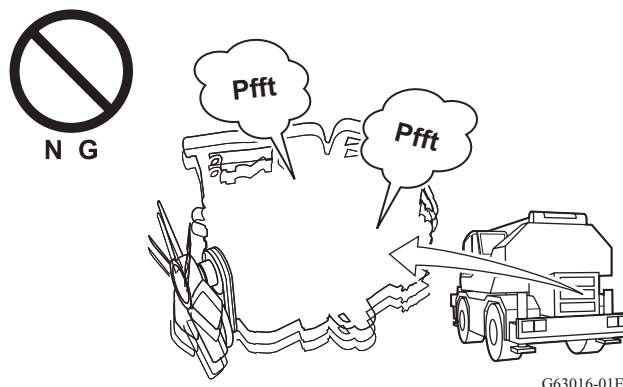

Condition in Engine Low Speed and Acceleration

CAUTION

Pay sufficient attention to the traffic condition around the vehicle, and perform inspection at a safe place.

1. Slowly travel in a safe place, and check the engine condition at a slow speed.
2. Accelerate the vehicle gradually, and check that the engine speed increases smoothly.
3. If the engine stops at a low speed, or does not accelerate smoothly, contact your nearest TADANO distributor or dealer for maintenance.

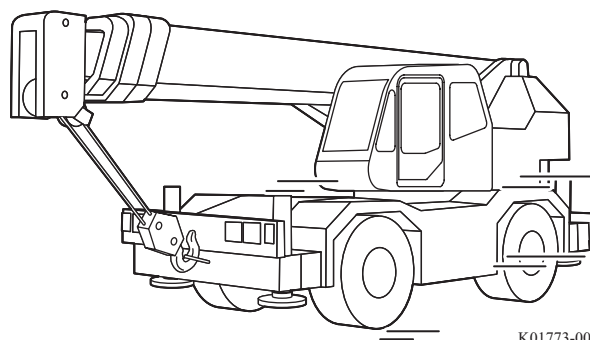

View from Mirror

1. Check for flaws on the mirror and reflection (whether visibility is secured).
2. Adjust the mirror to the position where you can obtain good visibility.



Check of Lamp Operation

1. Inspect that each lamp lights up or flashes when the corresponding switch is turned "ON".

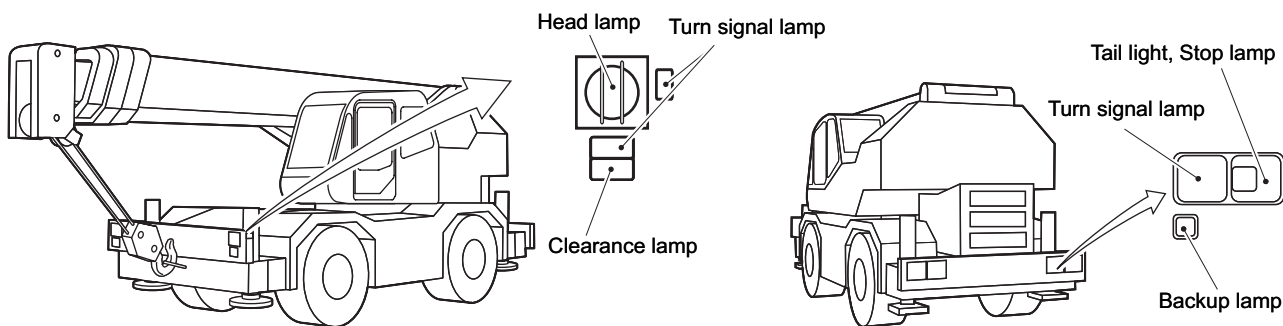

K03162-00E

2. Inspect that the beam direction and brightness are normal.
3. Inspect that the stop lamps light up when the brake pedal is depressed.

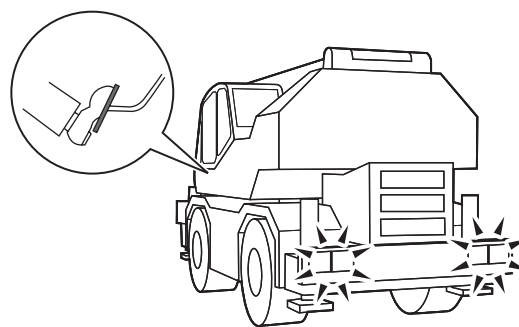

K01776-000

4. Inspect that the backup lamps light up when the shift lever is set to "R".
5. Inspect that each warning lamp and indicator lamp operates correctly. It is normal when each warning lamp is not lit after the engine is started.
6. If a lamp does not light up or flash, or if a turn signal lamp flashing becomes quicker, the bulb or the fuse can be burned out. Inspect and replace the defective parts.

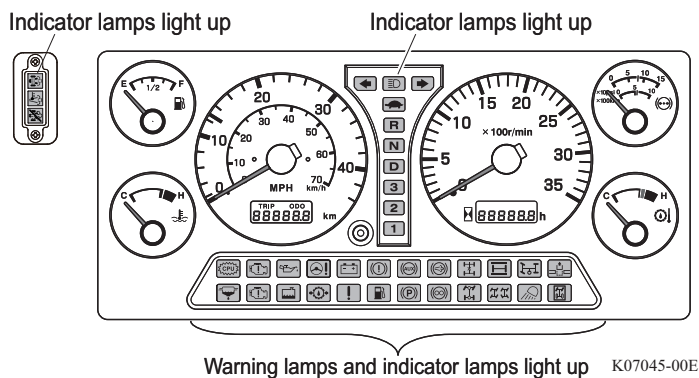

K07045-00E

Washer Liquid Level, Spraying Condition

1. Remove the cover on the front side of the cab.
2. Check that the washer liquid level is sufficient.
3. If the level is low, add the washer liquid into the window washer tank.

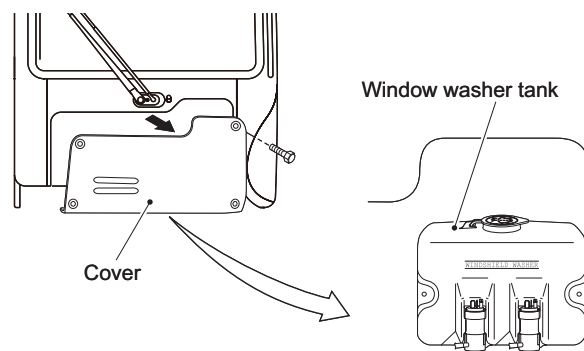

K01791-01E

4. Spray the washer liquid and inspect that the spraying direction and height are proper.
5. If the washer liquid is not sprayed when the washer liquid remains in the tank, the nozzle can be clogged.
Clean the nozzle with a needle to remove the clogging.
6. If the liquid is not sprayed after cleaning, the pump can be failed. Contact your nearest TADANO distributor or dealer for maintenance.

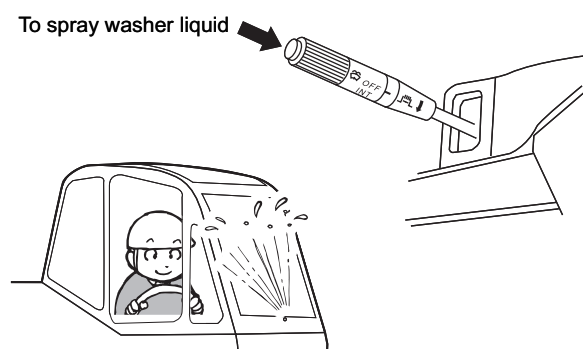

G63021-00E

Operation of Wipers

1. Spray the windshield washer liquid before inspecting the operation of the wipers.
2. Set the wiper operation speed to "INT", "LO", and "HI" respectively, and check that it properly operates.
3. If the wiping is uneven or the blade chatters, inspect the wiper blade. If it is deteriorated, replace it with a new one.
4. If the wipers do not work properly, contact your nearest TADANO distributor or dealer for maintenance.

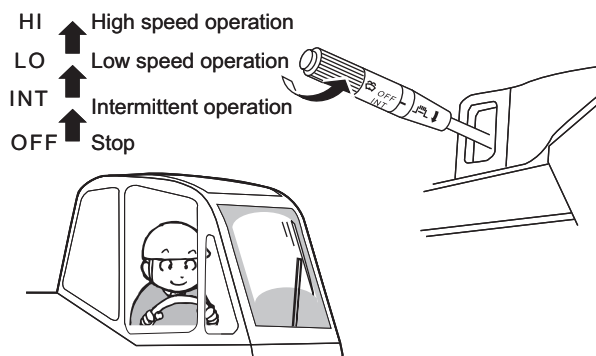

G63022-01E

Function of Foot Brake

Air Pressure, Rising Condition

⚠ WARNING

Do not start to travel if the air pressure gauge reading is below the red mark (lower limit of the specified pressure) and the low air pressure warning is lit.

Otherwise, the braking force of the foot brake decreases and the parking brake drags, and they can cause an accident.

Start traveling after the air pressure becomes the specified value and the low air pressure warning goes out.

Make sure that the pointer of the air pressure gauge exceeds the specified value (red mark).

If the air pressure does not rise, or it takes a long time for the pressure to rise, contact your nearest TADANO distributor or dealer for maintenance.

- ☞ Discharge the air in the air tank completely while the engine is stopped, then start the engine. It is normal when the pointer on the air pressure gauge goes to the specified value (red mark) at idling within 6 minutes.

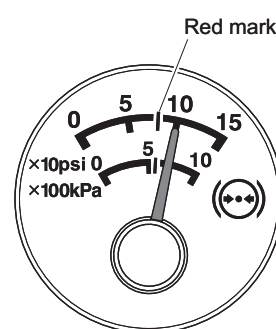

K01218-00E

Response to Depressing Brake Pedal

1. Depress the brake pedal all the way while the engine is running, and check that the depressing response is normal.
2. Release the pedal, and check that the pedal completely returns without sticking.
3. If any abnormality is found, contact your nearest TADANO distributor or dealer for inspection and maintenance.

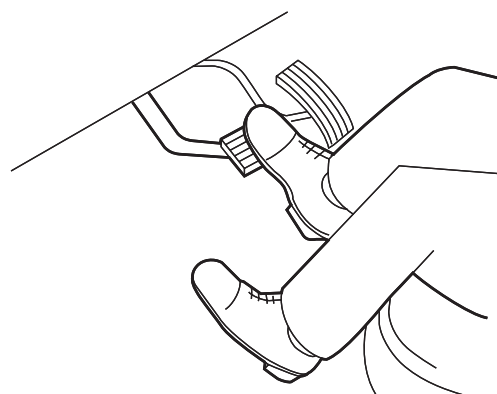

G16003-000

Exhaust Sound on Air Brake Valve

Depress the brake pedal, and release it. When there are some exhaust sounds (air evacuating sound) of the brake valve operation at this time, it is normal.

If any abnormality is found, contact your nearest TADANO distributor or dealer for inspection and maintenance.

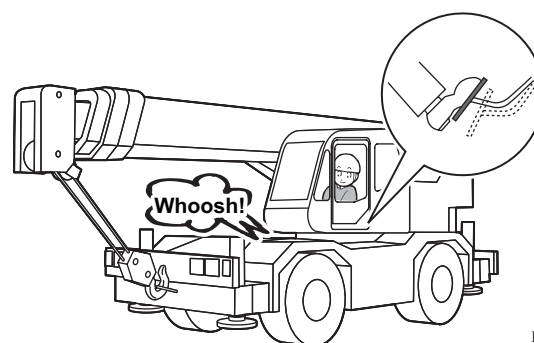

K01777-00E

Braking condition

CAUTION

Pay sufficient attention to the traffic condition around the vehicle, and perform inspection at a safe place.

Slowly travel in a safe place, apply the brakes, and inspect the braking condition.

If the brakes function poorly or unevenly, inspect the brakes.

 Refer to the "Disk Brake Pad" (page 389)

If any abnormality is found, contact your nearest TADANO distributor or dealer for inspection and maintenance.

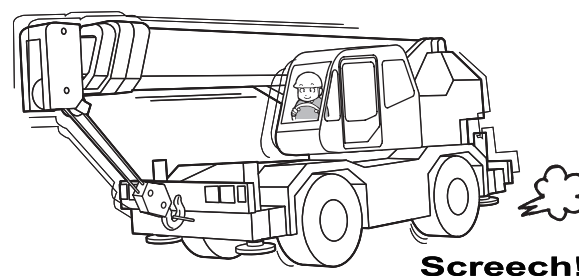

K01778-00E

Function of Parking Brake

⚠ CAUTION

Inspect the parking brake on a level ground with the brake pedal depressed.

Start the engine, and inspect when the air is at the specified pressure.

Inspect that the exhaust sounds (air evacuating sound) can be heard for the parking brake operation when the parking brake switch is set to "PARK".

- The brake warning lights up.

If any abnormality is found, contact your nearest TADANO distributor or dealer for inspection and maintenance.

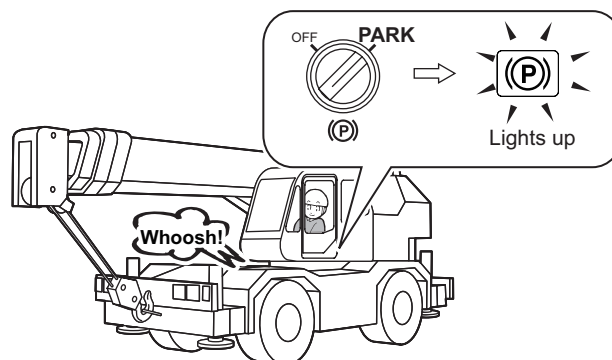

K01779-00E

Pre-operational Inspection

WARNING

If pre-operational inspections are neglected, it is impossible to find problems in their early stages and it may result in accidents. Perform pre-operational inspections, and take corrective action immediately if any abnormality is found.

Inspect the following items in the pre-operational inspections.

If you find any abnormality, take corrective actions by yourself, or contact your nearest TADANO distributor or dealer for maintenance.

- Hydraulic System
 1. PTO System Operating State, Oil Leaks
 2. Oil Level in the Hydraulic Oil Tank
 3. Oil Leaks in the Piping and Hose

- Control system
 1. Operating State of the Control Levers and Control Switches
 2. Oil Leaks in the Control Valves

- Outrigger system
 1. Bubble State in the Level
 2. Damage to the Outriggers
 3. Outrigger Mounting State
 4. Operating State of and Oil Leak in the Beam Cylinders and Jack Cylinders
 5. Spontaneous Lowering of the Carrier

- Swing system
 1. Operating State and Oil Leakage of Swing Speed Reducer, Swing Motor, and Rotary Joint
 2. Swing Brake Operation, Oil Leaks

- Boom, jib system
 1. Damage to the Boom, Jib, and Single Top
 2. Boom, Jib Mounting State
 3. Operating State of and Oil Leaks in the Boom Elevating Cylinder and Telescoping Cylinder
 4. Spontaneous Lowering of the Boom

- Lifting device
 1. Damage to the Winch
 2. Winch Operating State, Oil Leaks
 3. Check of Wire Ropes, Sheaves, and Guides
 4. Hook Block Mounting State, Damage

- Safety devices

1. Anti-Twoblock Device Operating State
Indicator Function Check
2. Registration of Operating State and Load Moment
3. Work Lamp Operating State
4. Mounting State of the Steps and Rails
5. Operation of Other Safety Devices (Options)

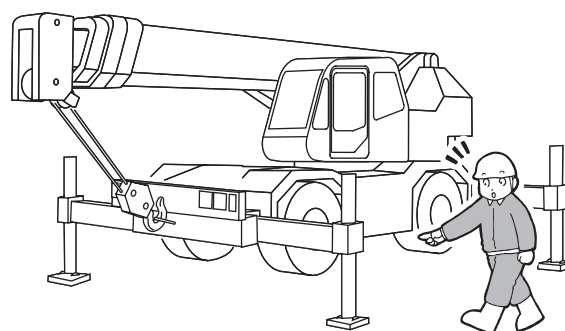

K01780-000

Hydraulic System

PTO System Operating State, Oil Leaks

1. Set the PTO switch to "ON" to check that the PTO indicator on the instrument panel lights up, and the display appears on the load moment indicator.

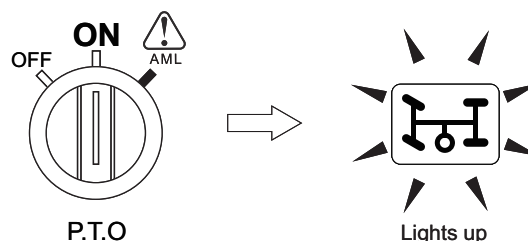

K01262-00E

2. Check for any abnormal noise or oil leaks from the hydraulic pump. If there is any abnormal noise or oil leakage, contact your nearest TADANO distributor or dealer for inspection and maintenance.

Oil Level Check in the Hydraulic Oil Tank

1. Set the machine into the traveling configuration, and set it up on a level ground.
2. Inspect the oil level with the oil level gauge on the hydraulic oil tank. If the oil level is between the position corresponding to the current ambient temperature and 32°F (0°C), the oil amount is normal. If it is insufficient, remove the cap of the hydraulic oil tank, and add oil.

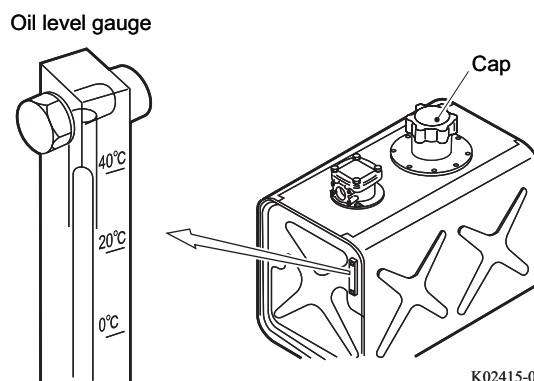

K02415-00E

Oil Leaks from the Piping and Hose

Check for any oil leaks from the piping and hose, and damage of hose.

If there is any oil leakage or damage, contact your nearest TADANO distributor or dealer for inspection and maintenance.

Control System

Operating State of the Control Levers and Control Switches

- 1.** Operate each control lever and each control switch while the engine is stopped.
- 2.** Check that each control level and control switch moves smoothly, and is not caught during stroke.
If it does not move smoothly or there is a tight spot, contact your nearest TADANO distributor or dealer for inspection and maintenance.

Oil Leaks from the Control Valves

Check for any oil leaks from the control valves after operating each control lever and each control switch.

If there is oil leakage, contact your nearest TADANO distributor or dealer for inspection and maintenance.

Outrigger System

Bubbles in the Level

Check for damage to the level, and the bubble in the Level.

If any damage is found, replace the level.

Damage to Outriggers

Check the outer case, inner case, and float for any crack and deformation.

If any deformation or damage is found, contact your nearest TADANO distributor or dealer for inspection and maintenance.

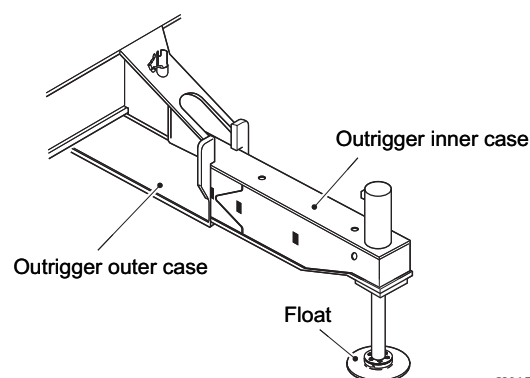

K01781-00E

Outrigger Mounting State

1. Check the mounting state of the slide cylinders and jack cylinders.
2. Check the mounting state of the float mounting bolts.

If any abnormality is found in the mounting state, contact your nearest TADANO distributor or dealer for inspection and maintenance.

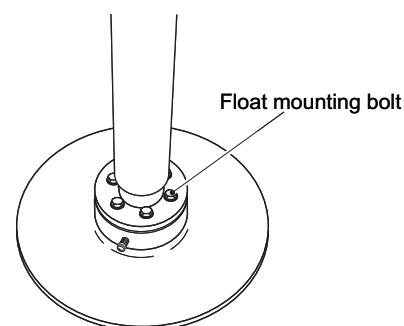

G64006-00E

Operating State of and Oil Leaks in the Beam Cylinders and Jack Cylinders

1. Operate the slide cylinders and jack cylinders, and check the operating state.
2. Check for any oil leaks from each cylinder. If any abnormality is found in the operating state or there is oil leakage, contact your nearest TADANO distributor or dealer for inspection and maintenance.

Spontaneous Lowering of Carrier

1. Extend the outriggers, and set up the machine horizontally. Then, stop the engine.
2. Turn the starter switch to "ON" without starting the engine, and extend/retract the jack cylinders.
3. Check that the carrier does not spontaneously lower (the jack cylinders do not retract).

If the carrier spontaneously lowers, contact your nearest TADANO distributor or dealer for inspection and maintenance.

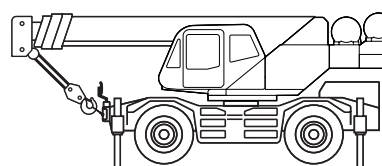
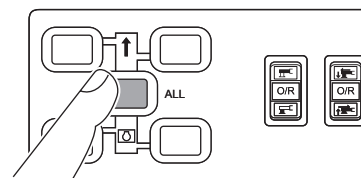

K02416-00E

Swing System

Operating State and Oil Leakage of Swing Speed Reducer, Swing Motor, and Rotary Joint

1. Perform swing operation, and check the swing operating state.
2. After swing operation, check for any leaks from the swing speed reducer, swing motor, or rotary joint. If any abnormality in the operation or oil leaks are found, contact your nearest TADANO distributor or dealer for inspection and maintenance.

Swing Brake Operation, Oil Leakage

1. Set the swing brake switch to "ON".
2. Perform swing operation in idling, and check that swing operation is not possible. If the swing brake does not work or there are any oil leaks, contact your nearest TADANO distributor or dealer for inspection and maintenance.

Boom, Jib System

Damage to the Boom, Jib, and Single Top

Check for any crack, deformation, or damage.

If there is any crack or deformation, contact your nearest TADANO distributor or dealer for inspection and maintenance.

Boom, Jib Mounting State

Check the mounting state of each mounting pin.

If there is any abnormality in the mounting state, contact your nearest TADANO distributor or dealer for inspection and maintenance.

Operating State and Oil Leakage of Boom Elevating Cylinder and Boom Telescoping Cylinder

1. Operate the boom elevating cylinder and boom telescoping cylinder to check the operating state.
2. Check for any oil leaks from each cylinder.
If there is oil leakage, contact your nearest TADANO distributor or dealer for inspection and maintenance.

Spontaneous Lowering of Boom

1. Perform the boom raising and boom extending operations.

 Stop operation just before each cylinder reaches the stroke ends.

2. Stop the engine.

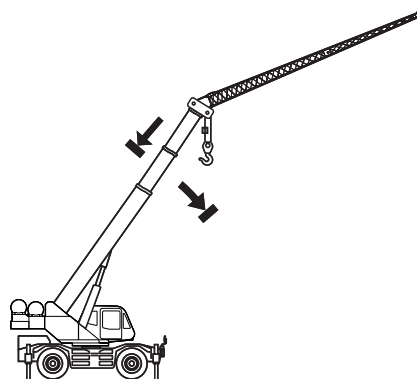

K02417-000

3. Check that the boom does not spontaneously lower (each cylinder does not retract).

If the boom spontaneously lowers, contact your nearest TADANO distributor or dealer for inspection and maintenance.

Lifting Device

☞ Check both the main winch and the auxiliary winch.

Damage to the Winch

Check that the winch speed reducer and winch mounting bracket are not deformed or damaged.

If any deformation or damage is found, contact your nearest TADANO distributor or dealer for inspection and maintenance.

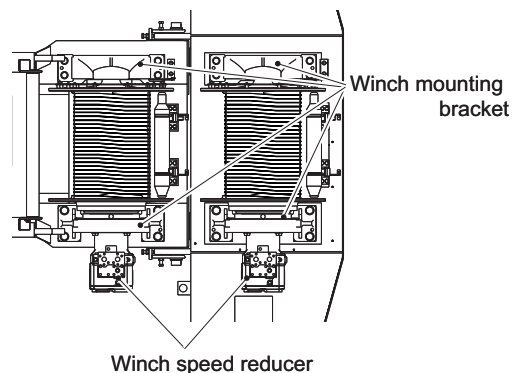

K02968-00E

Winch Operating State, Oil Leaks

1. Perform winch winding-up/down operations, and check the winch operating state.
2. After the winch operation, check for any oil leaks from the winch. If any abnormality in the operation or oil leaks are found, contact your nearest TADANO distributor or dealer for inspection and maintenance.

Check of Wire Ropes, Sheaves, and Guides

1. Check for any crack, wear, deformation of the rope end, and damage to the rope terminals.

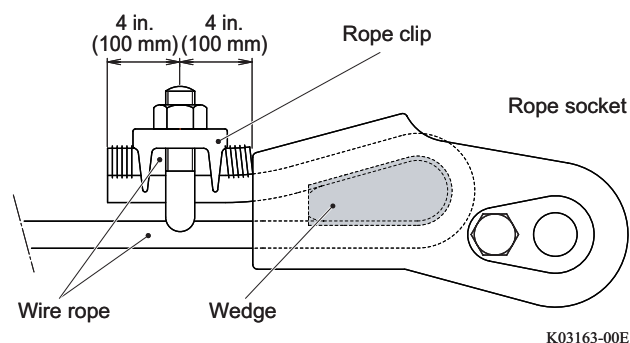

2. Check that the wire rope is not wound up disorderly on the winch drum.

If it is wound up disorderly, rewind it.

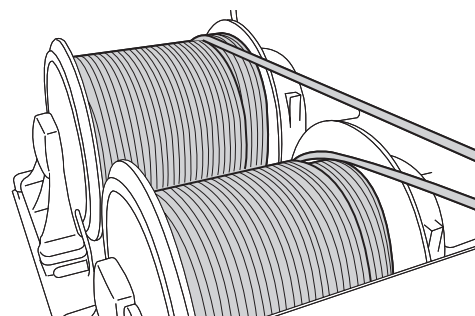

The wire rope is correctly wound on the winch drum

3. Check the wire rope for wear, damage of outer layer and inner layer, breakage, reduction in outside diameter, and drying conditions. If any abnormality is found, replace the wire rope.
4. Extend the outriggers, and set up the machine horizontally.



5. Raise the boom to approximately 45°, and check that the wire rope correctly passes through the sheaves and guides. If the wire rope is out of track of the sheaves and guides, pass the wire rope through the sheaves and guides.

If any abnormality is found, contact your nearest TADANO distributor or dealer for inspection and maintenance.

Hook Block Mounting State, Damage

1. Check the mounting state of the rope socket, fixing pin, and fixing pin mounting bolt.

To attach the rope socket to the right of the boom

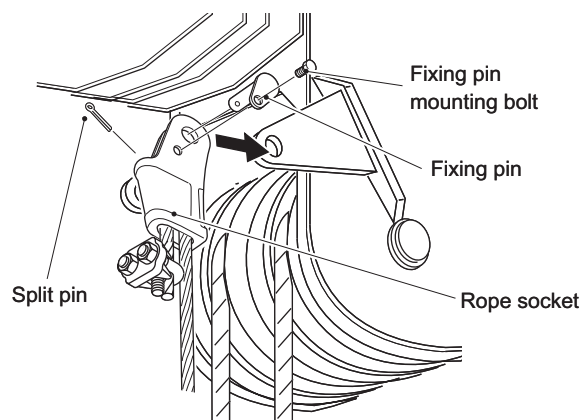

To attach the rope socket to the left of the boom

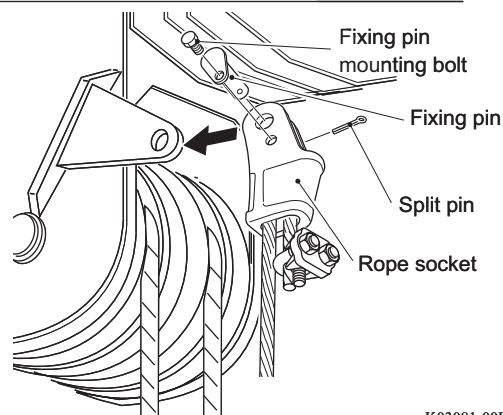

K03081-00E

2. Check the rotating state of the hook, function of the safety latch, and damage of each part. If any abnormality is found, contact your nearest TADANO distributor or dealer for inspection and maintenance.

Safety Devices

Operation of Anti-Twoblock Device

1. Extend the outriggers, and set the machine to the crane operation configuration. Then, slowly wind up the winch.
2. Check that the winch winding up operation stops automatically, the alarm buzzer (tremolo) sounds, and then the error code "W0024" is displayed on the load moment indicator. If the operation does not automatically stop, or the alarm buzzer does not sound, contact your nearest TADANO distributor or dealer for inspection and maintenance.

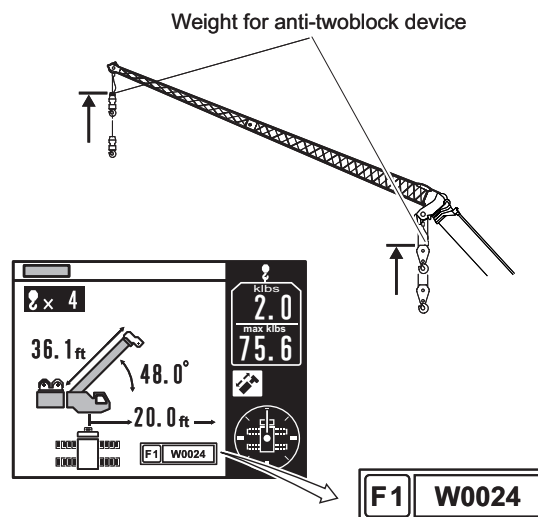

K03082-01E

Registration of Operating State and Load Moment Indicator Function Check

Register the lift state to the load moment indicator, and perform load moment indicator function check.

- ☞ For registration of the operating state and load moment indicator function check, refer to "Registration of Operating State and load moment indicator Function Check" (page 147).

If any abnormality is found, contact your nearest TADANO distributor or dealer for inspection and maintenance.

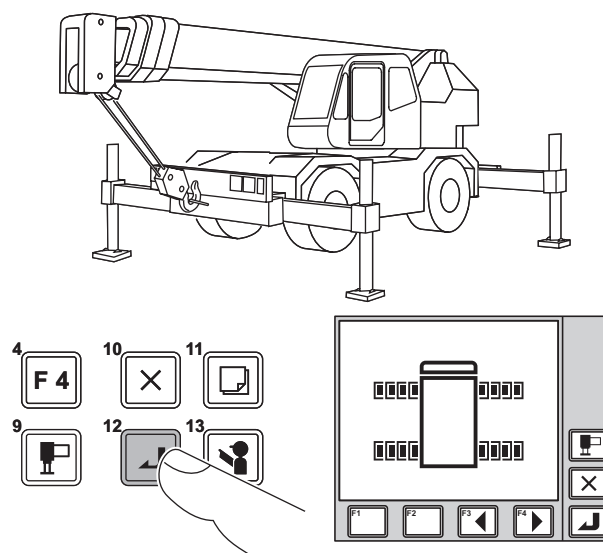

K01787-000

Work Lamp Operating State

Turn each work lamp switch to "ON", and check the lighting state of the work lamps.

If any work lamp does not light up, contact your nearest TADANO distributor or dealer for inspection and maintenance.

Mounting State of Steps and Rails

Check the access path to the cab for damage.

If any damage is found, contact your nearest TADANO distributor or dealer for inspection and maintenance.

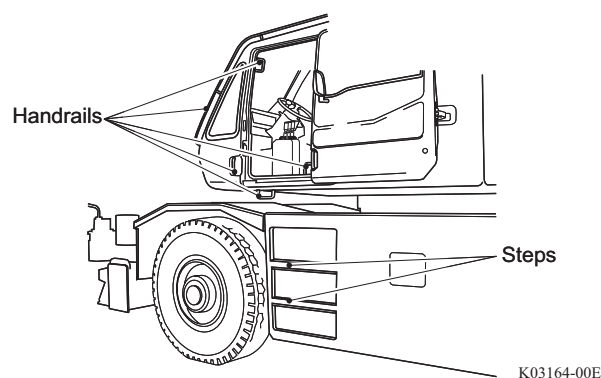

Operation of Other Safety Devices (Options)

Operation of Anemometer (Option)

Check that while the anemometer is rotating, wind speed is indicated on the wind speed display area.

If the device does not work properly, contact your nearest TADANO distributor or dealer for inspection and maintenance.

Inspection of Crane Structure

If the crane is heavily used (severe condition), inspect the items below for damage, wear, breakage, deformation, and abnormal noise when performing monthly periodic self-inspection at intervals within 1 month. If any abnormality is found as a result of the inspection, contact your nearest TADANO distributor or dealer for repair.

Boom Structure

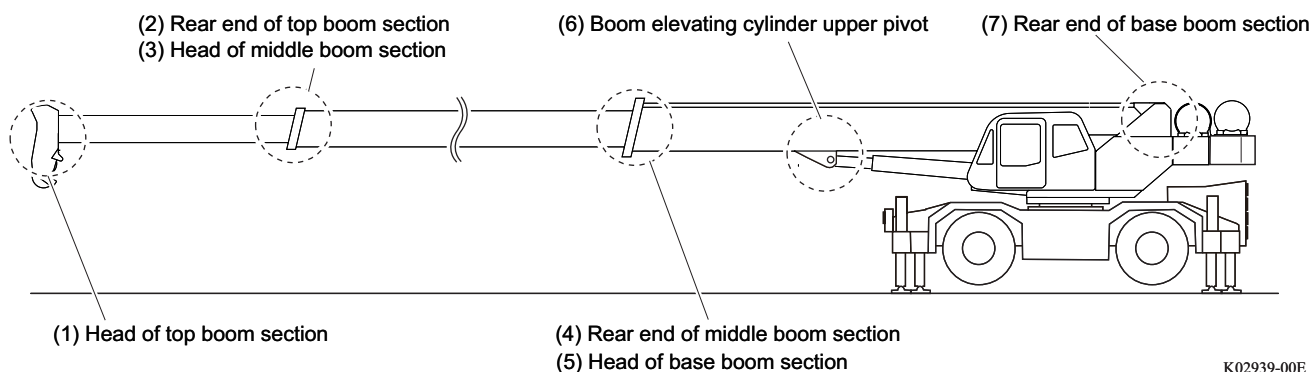

Jib Structure

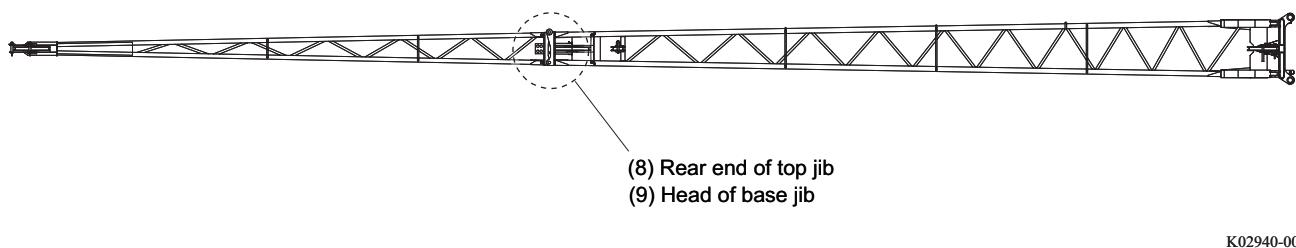

Swing frame

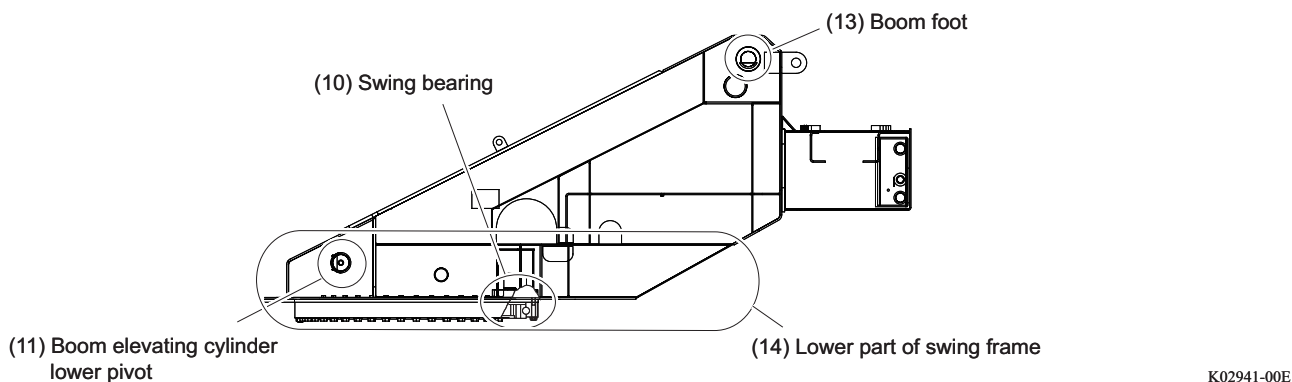

GR-750XL-2_OM2(U)-17E

Outrigger Structure

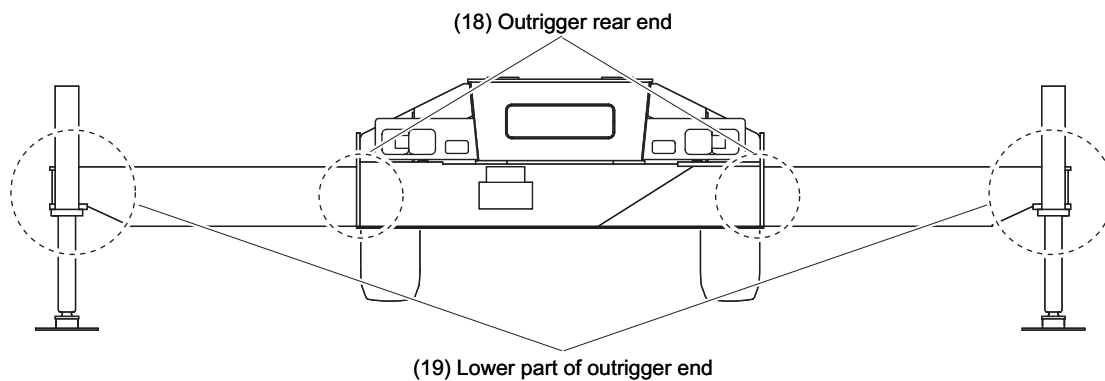

K02942-00E

Chassis Frame

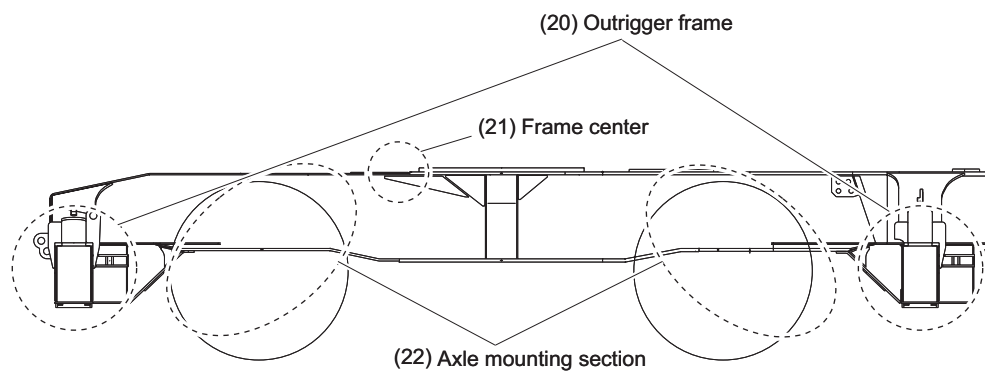

K02943-00E

Greasing

NOTICE

- **Do not use different brands of grease together.**
Using different brands of greases together can change the properties of the greases and cause an adverse effect on the machine. When adding greases, use the same brand of greases as they are already in the machine.
If a different brand of grease must be used, be sure to remove all the remaining grease before adding the new grease.
- **If dust enters, it causes the premature wear of the sliding surfaces, and consequently, shortens the life of the crane. Clean the grease nipples and surfaces which require lubrication before applying the greases to prevent dust and other foreign matter from entering.**
- **Clean the wire ropes with a wire brush, etc., before they are greased.**
- **In addition to the areas listed in the "Maintenance table", the following areas should also be lubricated with grease in a timely manner to prevent rusting and ensure a smooth movement.**
 - **The areas of hydraulic cylinder rods (boom elevating cylinder, jack cylinder, etc.) that are exposed when the cylinder is fully retracted.**
 - **Links and sliding sections that have been coated with grease before the shipment from the factory.**

Greasing is necessary to minimize the wear on the sliding and rotating parts, and extend the life of the machine as well as to operate smoothly.

For the bushes and bearings, fill new grease to force out the old grease.

Maintenance Table

	No.	Item	Points	Inspection and maintenance interval			
				1 week	100 h 1 month	Others	
Upper structure	(1)	Side and lower surface of boom (sliding sections)	Coat	4 points		●	
	(2)	Slide plate (Upper side of boom)	Inject	8 points	●		
	(3)	Wire rope (for main winch)	Coat	1 point		●	
	(4)	Wire rope (for auxiliary winch)	Coat	1 point		●	
	(5)	Wire rope (for boom telescoping)	Coat	2 points		●	
	(6)	Swing bearing	Inject	3 points	●		
	(7)	Swing gear	Coat	1 point		●	
	(8)	Jib connecting pin boss	Inject	4 points		●	
	(9)	Jib end sheave pin	Inject	2 points	●		
	(10)	Boom elevating cylinder lower pivot pin	Inject	1 point	●		
	(11)	Boom bottom pivot pin	Inject	1 point	●		
	(12)	Main hook block (option)	Inject	1 point	●		
	(13)	Auxiliary hook block (option)	Inject	1 point	●		
Lower structure	(21)	Outrigger float	Inject	4 points	●		
	(22)	Propeller shaft	Inject	9 points		●	
	(23)	Suspension lock cylinder	Inject	4 points		●	
	(24)	King pin	Inject	8 points		●	
	(25)	Steering cylinder	Inject	8 points		●	
	(26)	Tie rod end	Inject	4 points		●	
	(27)	Axle oscillation pivot pin	Inject	2 points		●	

 For the brands of grease, refer to "Oils and Greases" (page 451).

Greasing Chart

Upper structure

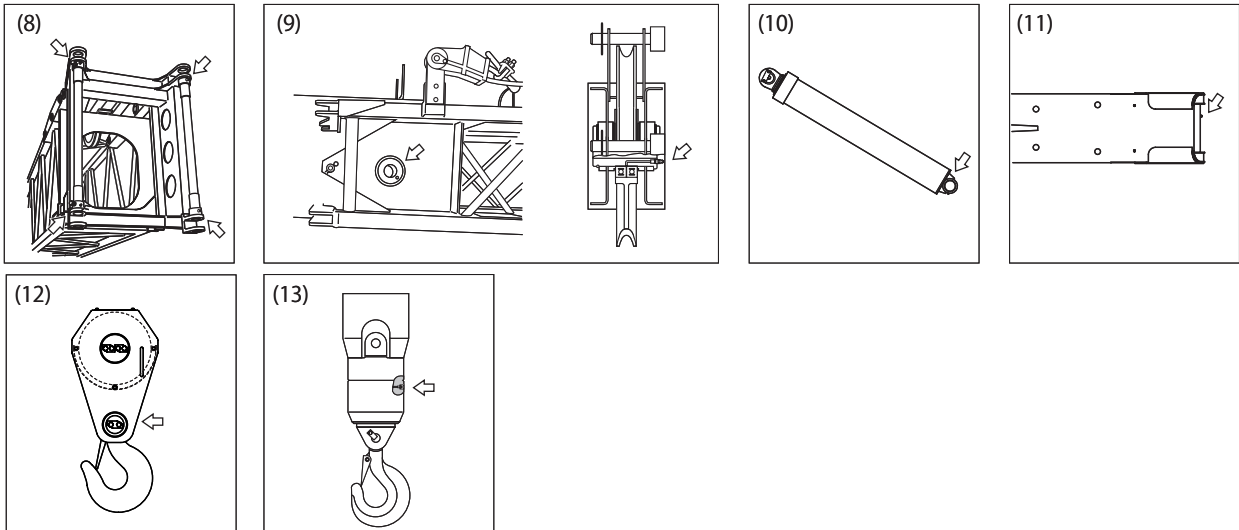
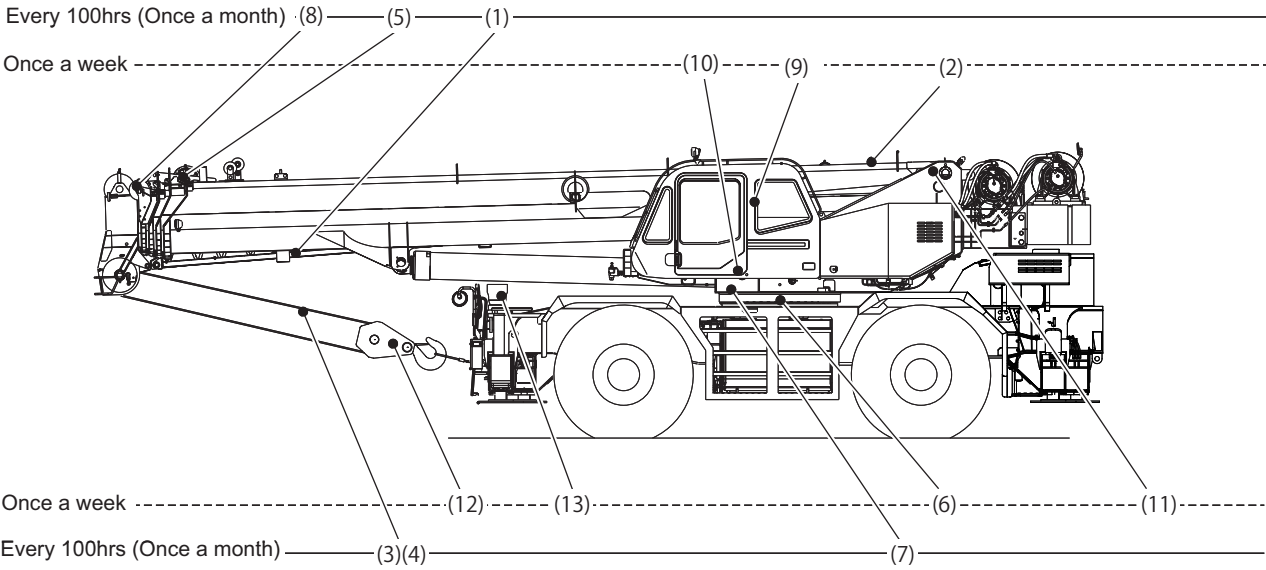
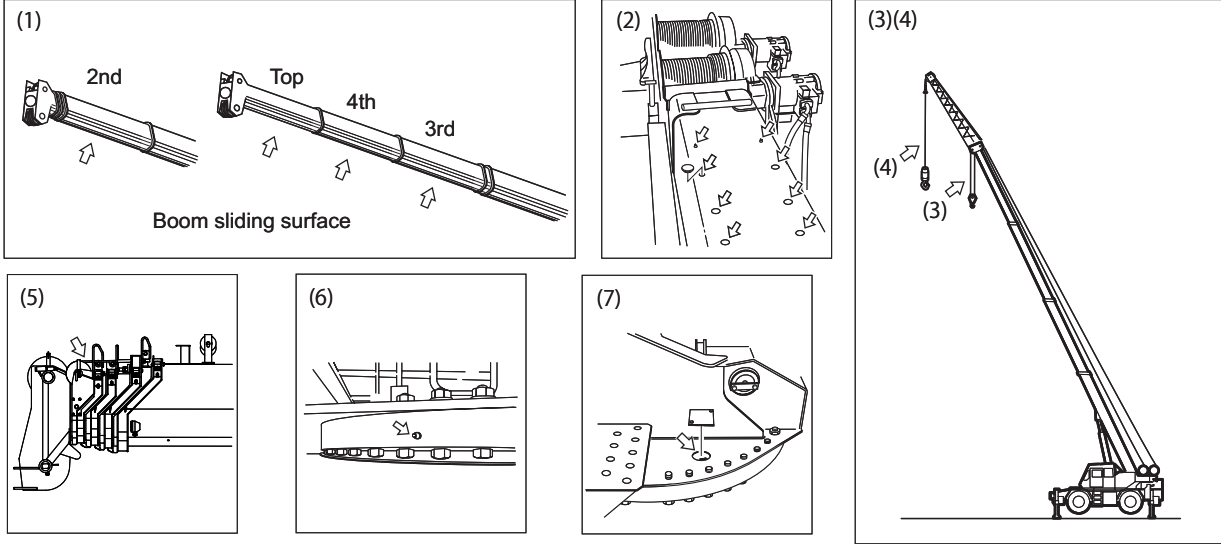

GR-750XL-2_OM2(U)-17E

Lower structure

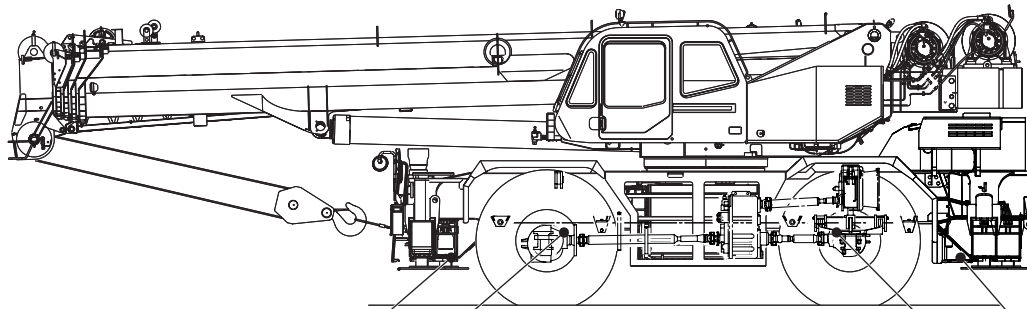

- Once a week ----- (21)----- (21)
- Every 100 hrs (Once a month) --- (22) (23) (24) (25) (26) (27) --- (22) (23) (24) (25) (26) (27) ---
- Every 2400 hrs (Every 2 years) _____

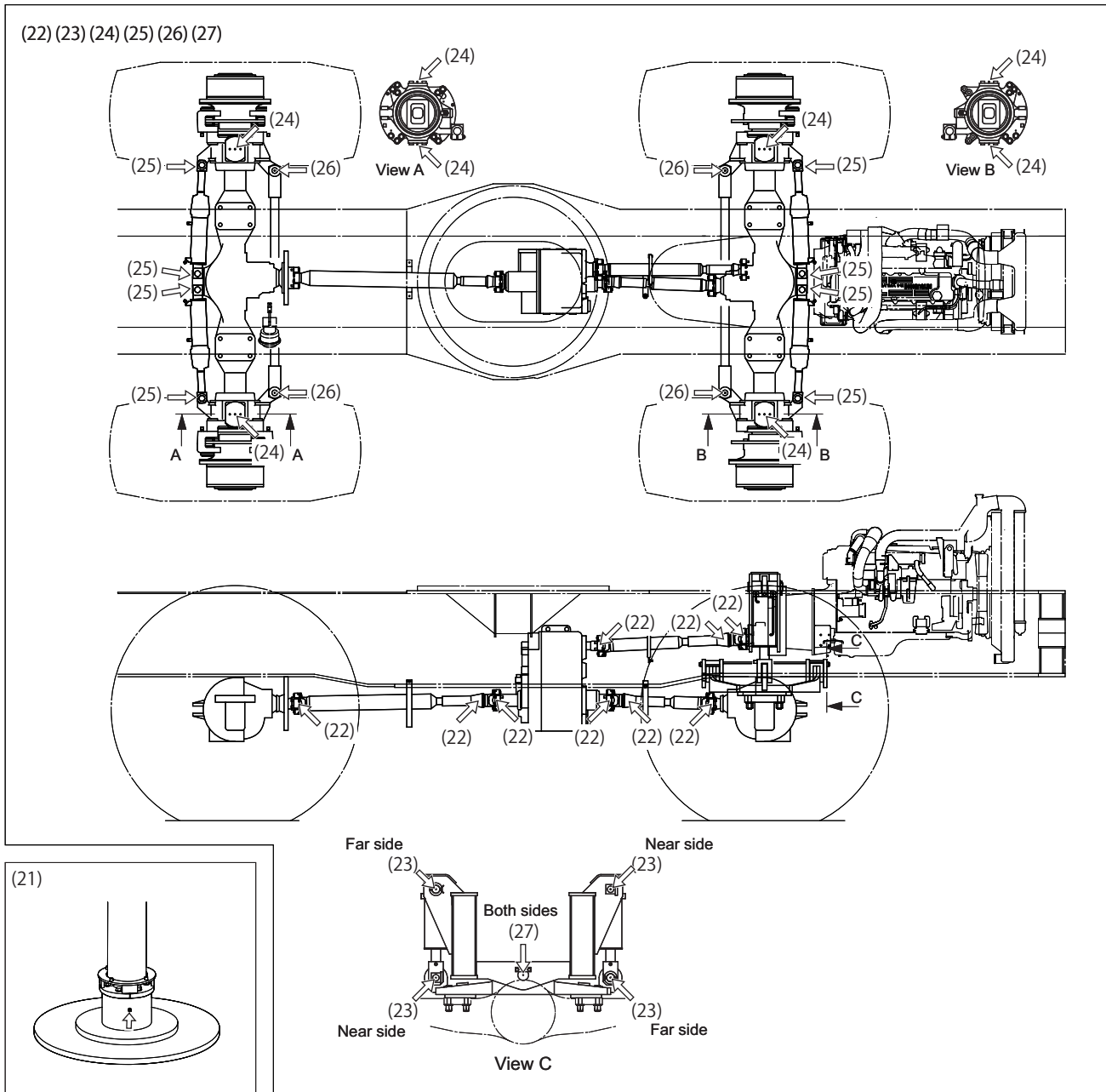

K07047-00E

GR-750XL-2_OM2(U)-17E

Slide Plate (Upper Surface of Boom) (Fig. 1)

1. Fully extend the outriggers, and set up the crane horizontally.
2. Fully retract the boom, and lower it to the horizontal position.
3. Apply grease.

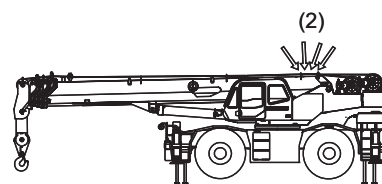

Fig.1

K07048-00E

Sides and Lower sides of Boom, Wire ropes (for boom telescoping) (Fig 2,3)

1. Fully extend the outriggers, and set up the crane horizontally.
2. Fully retract the boom, and lower it to the horizontal position.
3. Fully extend the 2nd boom section in Boom telescoping mode I, and then supply grease to the points shown in Fig. 2.
4. Completely retract the Boom.
5. Fully extend the 3rd, 4th and top boom sections in Boom telescoping mode II, and then supply grease to the points shown in Fig. 3.

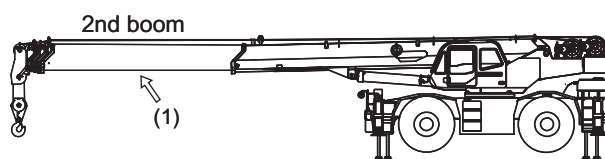

Fig.2

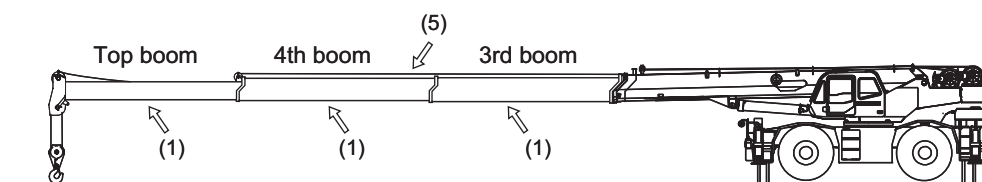

Fig.3

K07049-00E

Gear Oil

NOTICE

- **Do not use different brands of gear oil together.**
The properties of the oil change and can cause an adverse effect on the machine. When adding gear oil, use the same brand that is already in the machine.
If a different brand of gear oil must be used, be sure to drain all the remaining gear oil before adding a new oil.
- **Before you remove a plug, clean the area around the plug to prevent dust and other foreign matter from entering.**
- **Wrap a sealing tape around the taper plug, and tighten the plug until it does not turn any more. Do not over-tighten them, or the plug mounting portion may be damaged.**
- **Refer to the "Oils and Greases" section and choose an oil of the grade and viscosity suitable to the ambient temperature. If an unsuitable oil is used in an extremely cold environment, the oil can harden and cause machine damage or malfunction.**

Maintenance Table

No.	Item	Points/ Quantity	Inspection and maintenance interval					
			1 week	100 h	300 h	600 h	1200 h	2400 h
				1 month	3 months	6 months	1 year	2 years
1	Winch speed reducer (Main/auxiliary winch)	Oil level check	2 points			●		
		Oil replacement	1.59 gal (6 L) x 2		◎		●	
2	Swing speed reducer	Oil level check	1 point			●		
		Oil replacement	1 gal (3.8 L)		◎		●	
3	Axle (Carrier)	Oil level check	2 points		●			
		Oil replacement	7 gal (26.5 L) x 2	◎				●
4	Axle (Planetary Gear)	Oil level check	4 points		●			
		Oil replacement	1.32 gal (5 L) x 4	◎				●

◎: First replacement only

 For brands of gear oil, refer to "Oils and Greases" (page 451).

Winch Speed Reducer (Main/Auxiliary Winch)

CAUTION

The winch speed reducer are very hot immediately after the operation, and you may suffer burns if you work on them. Before you start the work, let them cool down until you can touch them by bare hands.

Oil level check

1. Set up the machine on a level ground.
2. Remove the level plug, and check the oil level. When the oil level is up to the bottom of the plug hole, the oil amount is sufficient. If it is insufficient, remove the filler plug and add oil through the filler plug hole.
3. Wrap sealing tapes around the level plug and filler plug and tighten them.

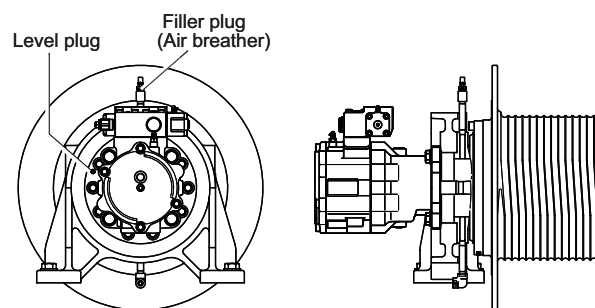

K02009-00E

Oil replacement

1. Set up the machine on a level ground.
2. Direct the drain plug (B) downward by winch operation.
3. Place an oil pan under the drain plug (A) and the drain plug (B).
4. Remove the drain plug (A), the drain plug (B), filler plug, and level plug, and then drain the oil.
5. After all the oil has drained out, wrap a sealing tape around the drain plug (A) and (B), and tighten the plugs.
6. Add new gear oil through the filler plug hole until the oil overflows from the level plug hole.
7. Wrap sealing tapes around the level plug and filler plug and tighten them.

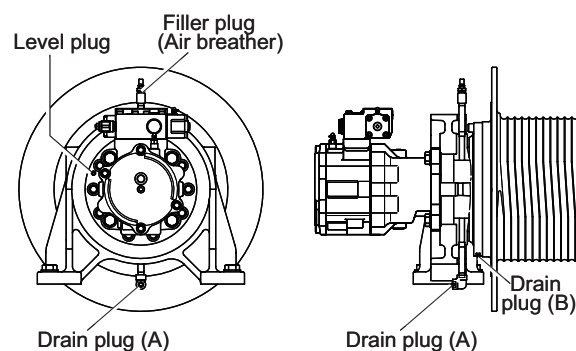

K02010-00E

Swing Speed Reducer

⚠ CAUTION

The swing speed reducer is very hot immediately after the operation, and you may suffer burns if you work on them. Let it cool down until it can be touched by bare hands before starting the work.

Oil level check

1. Extend the outriggers, and set up the machine horizontally.
2. Raise the boom to an angle where it does not hinder the work.
3. Remove the level plug, and check the oil level. If the oil level reaches the bottom of the plug hole, the oil amount is sufficient. If it is not sufficient, remove the filler plug and add oil through the filler plug hole.
4. Wrap sealing tapes around the level plug and filler plug and tighten them.

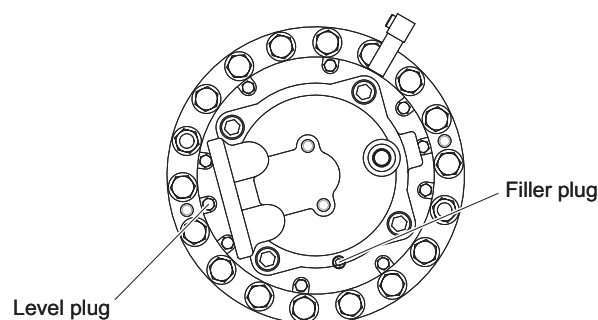

K02011-00E

Oil replacement

1. Extend the outriggers, and set up the machine horizontally.
2. Raise the boom to an angle where it does not hinder the work.
3. Remove the drain plug and attach a vinyl hose to the drain port. Then remove the filler plug, and drain the oil.

 The vinyl hose is to be prepared by customer.

4. After all of the oil has drained out, remove the vinyl hose. Wrap a sealing tape around the drain plug and tighten it.
5. Add new gear oil through the filler plug hole until the oil overflows from the level plug hole.
6. Wrap sealing tapes around the level plug and filler plug and tighten them.

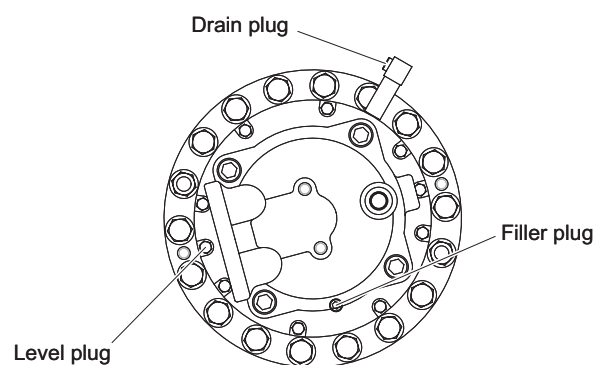

K02012-00E

Axle (Carrier)

⚠ CAUTION

The axles are very hot immediately after the operation, and you can suffer burns if you work on them. Let the axle cool down until it can be touched by bare hands before working on it.

Oil level check

1. Set up the machine on a level ground.
2. Remove the filler/level plug, and check the oil level. When the oil level reaches the bottom of the plug hole, the oil amount is adequate. If the oil level is low, add oil through the plug hole.
3. Wrap a sealing tape around the filler/level plug, and tighten the plug.

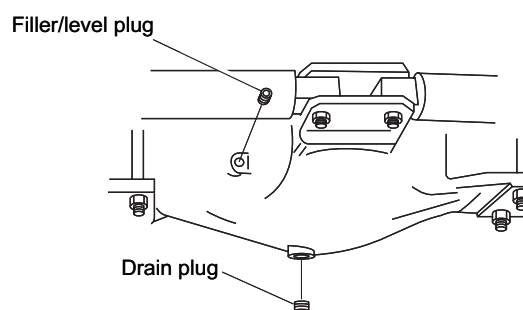

G68004-00E

Oil replacement

1. Set up the machine on a level ground.
2. Place an oil pan.
3. Remove the drain plug and filler/level plug, and then drain the oil.
4. After all the oil has drained out, wrap a sealing tape around the drain plug and tighten the plug.
5. Add new gear oil until the oil overflows from the filler/level plug hole.
6. Wrap a sealing tape around the filler/level plug, and tighten the plug.

Axle (Planetary Gear)

⚠ CAUTION

The axles are very hot immediately after the operation, and you can suffer burns if you work on them. Let the axle cool down until it can be touched by bare hands before working on it.

Oil level check

1. Extend the outriggers, and set up the machine horizontally.
2. Rotate the tire by hand until the indication "OIL LEVEL" becomes horizontal as shown in the illustration on the right.
3. Remove the drain/level plug, and check the oil level. When the oil level reaches the bottom of the plug hole, the oil amount is adequate. If the oil level is low, remove the filler plug and add oil through the filler plug hole.
4. Wrap a sealing tape around the filler plug and drain/level plug, and tighten them.

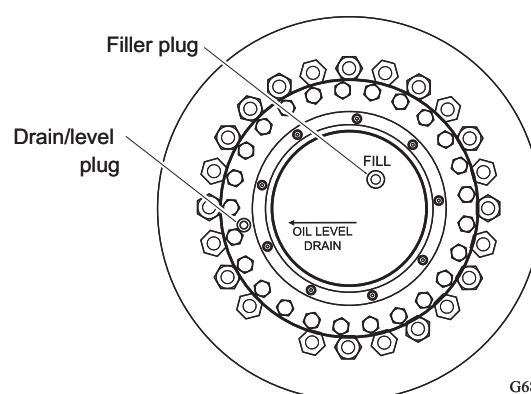

Oil replacement

1. Extend the outriggers, and set up the machine horizontally.
2. Rotate the tire by hand to move the drain/level plug to the lowest position as shown in the illustration.
3. Place an oil pan.
4. Remove the drain/level plug and filler plug, and then drain the oil.

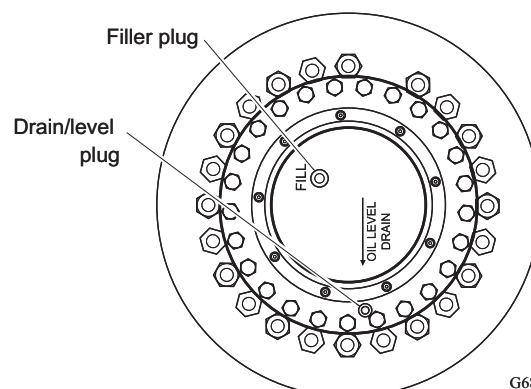

5. After all the oil has drained out, rotate the tire by hand until the indication "OIL LEVEL" becomes horizontal as shown in the illustration.
6. Add new gear oil through the filler plug hole until the oil overflows from the drain/level plug hole.
7. Wrap a sealing tape around the filler plug and drain/level plug, and tighten them.

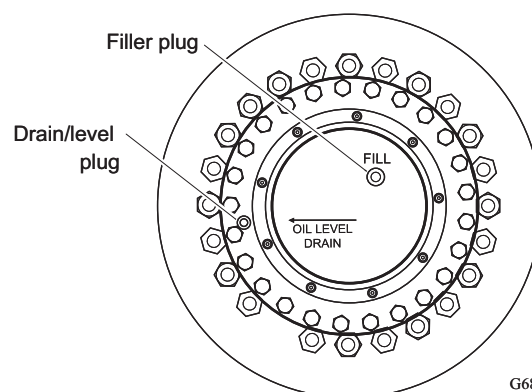

G68005-06E

Engine

NOTICE

- Do not use different brands of engine oil together. The properties of the oil changes and can cause an adverse effect on the machine. When adding engine oil, use the same brand that is already used in the machine.
If a different brand of oil must be used, be sure to drain all the remaining engine oil before adding the new oil.
- Use engine oil suitable for the outside air temperature. Refer to the separate engine manual to use an oil with suitable viscosity.

Maintenance Table

No.	Item		Points/ Quantity	Inspection and maintenance interval					
				125 h	250 h	500 h	1000 h	2000 h	5000 h
1	Engine	Replace oil	4.12 gal (15.6 L)			●			
		Replace oil filter	1 point			●			
2	Air cleaner	Inspect	1 point		●				
		Replace element		When red signal is indicated on dust indicator.					
3	DPF	Inspect and clean	1 point						●

- ☞ The inspection and maintenance intervals for the engine oil and oil filter is for when the engine oil type CJ-4 (API service category) is used.
- ☞ For procedures of engine oil and oil filter replacement, refer to the separate engine manual.
- ☞ For air cleaner inspection and element replace procedure, refer to the separate engine manual.
- ☞ For DPF inspection and cleaning, contact a TADANO distributor or dealer.
- ☞ For brands of engine oil, refer to "Oils and Greases" (page 451).

Radiator Fin

Clean

Remove the front cover of the radiator and clean the radiator with compressed air or a brush.

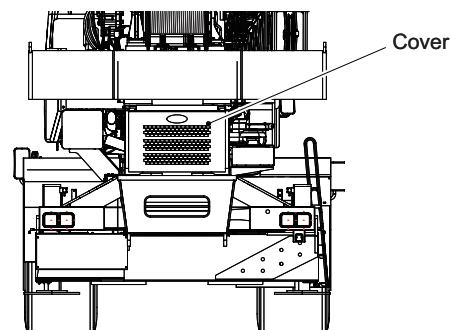

K07050-00E

Engine Cooling System

⚠ WARNING

- The coolant is very hot immediately after operation. If you open the radiator cap while the coolant is hot, the hot coolant can spout out and you can suffer burns. Let the coolant cool down before you start the work.
- When you handle long-life coolant (LLC), keep in mind the following:
 - LLC is poisonous. Do not ingest. If someone accidentally ingest it, immediately try to make the person vomit and seek medical attention. If the LLC gets in your eye, immediately flush it out with clean water and seek medical attention.
 - Keep the LLC away from fire. LLC is flammable.

NOTICE

- To prepare coolant mixture, use soft water.
Do not use water from wells or rivers.
- When you add the coolant, do not change the mixture ratio of the long-life coolant (LLC). Add coolant that has the same mixture ratio. Do not mix the LLC of different brands. If you must use different brand of LLC, drain all the remaining coolant before you add new coolant.
- Mix the long life coolant (LLC) with water in a 50:50 ratio.
- Keep the air conditioner turned on when you replace the coolant. The coolant in the air conditioner system is replaced only while the air conditioner in operation.

Maintenance Table

No.	Item		Points/ Quantity	Inspection and maintenance interval					
				60 h	100 h	300 h	600 h	1200 h	2000 h
					1 month	3 months	6 months	1 year	2 years
1	Coolant	Replace (Use long-life coolant.)	Approx 7.4 gal (28 L) (*1)						●
2	Coolant filter	Clean element	1 point					●	

(*1): 2.6 gal (10 L) in engine; 2.3 gal (8.8 L) in radiator; 2.4 gal (9.1 L) in piping, etc.

 For coolant replacement procedures, refer to the separate engine manual.

 For brands of long-life coolant, refer to "Oils and Greases" (page 451).

Coolant Filter

Element cleaning

1. Remove the hoses at inlet/outlet port of the filter, and stop the flow of the coolant.
2. Remove the coolant filter case located at the bottom of the rotary joint and clean the element. If the element is severely contaminated, replace it with a new one.

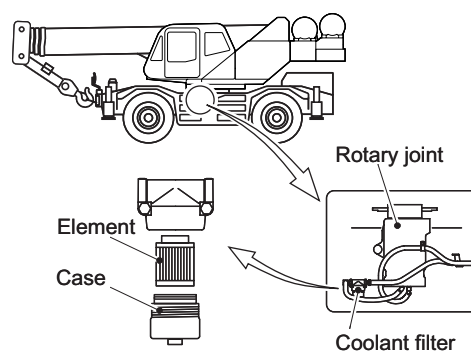

K03188-00E

Torque Converter System

NOTICE

- Do not use the different brands of torque converter oil together. Using different brands of torque converter oil together can change the properties of the oil and may have an adverse effect on the system.
If torque converter oil must be added, be sure to use the same brand of oil as that is already in the machine.
If another brand of torque converter oil must be used, drain all the remaining torque converter oil before adding new oil.
- Dust, foreign material or water in the torque converter circuit can cause a failure. Be especially careful when adding or replacing torque converter oil to prevent any foreign substances from entering the torque converter.

Maintenance Table

No.	Item	Points/ Quantity	Inspection and maintenance interval					
			1 week	100 h 1 month	300 h 3 months	600 h 6 months	1200 h 1 year	2400 h 2 years
1	Torque converter, transmission	Oil replacement	Approx. 9.2 gal (35 L) (*1)	○			●	
		Clean strainer		○			●	
2	Line filter	Replace element	1 point	○			●	

(*1): Total capacity ○:First replacement only

 For brands of torque converter oil, refer to "Oils and Greases" (page 451).

Transmission

CAUTION

The torque converter and transmission are very hot immediately after traveling, and you can suffer burns if you work on them. Before you start the work, let them cool down until you can touch them by bare hands.

NOTICE

- An excessively low or high oil level can cause the clutch to fail or overheat. Make sure that the oil level is in the specified range.
- Before you remove a plug, clean the area around the plug to prevent dust and other foreign matter from entering.

Oil replacement

When you replace the oil, also clean the strainer and replace the line filter.

1. Extend the outriggers, and set up the machine horizontally.
2. Swing the boom in the direction to make adding oil easier (approx. 90° to right or left), and stop the engine.
3. Remove the upper cover of the torque converter.

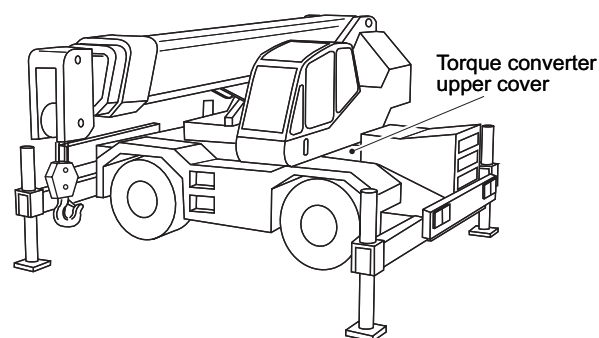

G72001-01E

4. Remove the drain plug at the lower part of the transmission and drain the oil.
5. Clean the drain plug, and tighten it.

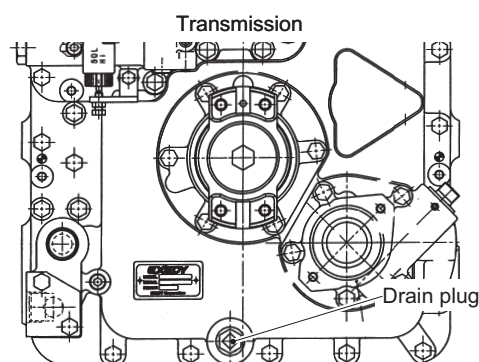

K02237-00E

6. Add oil through the torque converter filler port until the oil level is in the specified range of the transmission oil level gauge.

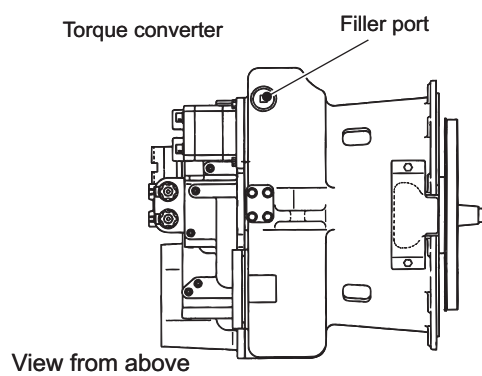

K02238-00E

7. Turn the PTO switch to "OFF", and put the shift lever in "Neutral". Then start the engine and let it idle.

- 8.** The oil level drops gradually as the oil passes through the torque converter, pipes, oil cooler, and filter, etc.
Add oil little by little to compensate for the drop in oil level. Keep the engine idling for approx. 5 minutes and continue to add oil until the oil level becomes stable in the specified range at the oil temperature of 122F° (50°C).
The specified oil level is between the "Hi" and "Low".

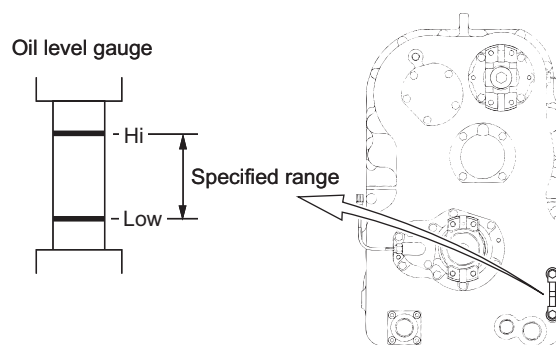

K04267-00E

Clean strainer

1. Refer to "Replacing Oil" and drain oil in the transmission.
2. Remove the strainer from the lower part of the transmission.

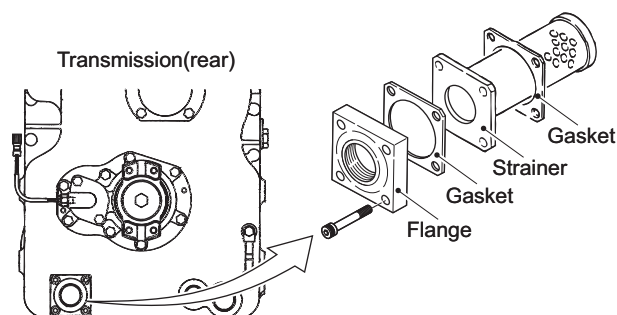

K02239-00J

3. Clean the bottom face of the transmission case through the strainer installation hole.
4. Immerse the strainer in volatile solvent such as kerosene, and clean it with a soft tool such as nylon brush.
5. Blow compressed air of 43.5 to 58.0 psi {300 to 400 kPa} on the inside of the strainer.
6. Dry out the strainer.
7. Attach the strainer in its initial position.
8. Refer to "Replacing Oil" and add oil into the transmission.

Line Filter

Replacing the Element (at Front Right of the Transmission)

Remove the case and replace the filter element.

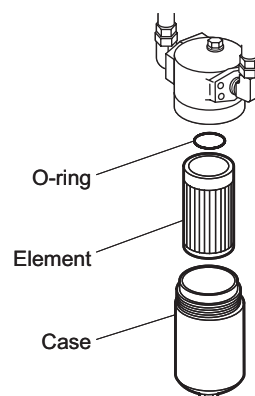

K00513-00E

Fuel System

⚠ WARNING

- Fuel leakage can cause a fire. If fuel leakage is found, repair it immediately. If fuel spills during filter replacement or fuel system bleeding, wipe it off completely. Spilled fuel can catch fire.
- Do not use fuel other than diesel fuel. Do not use diesel fuel mixed with gasoline or alcohol. They can cause engine trouble. They can also cause a fire or explosion, and serious injury or death, or damage to the machine can occur. Use standard diesel fuel only.

NOTICE

- Use ultra-low sulfur diesel fuel only. Use of other fuel can result in a violation of emission regulations and cause damage to the machine. For this engine, use ultra-low sulfur diesel fuel with the maximum sulfur content of 15 ppm in the United States or 10 ppm in the European Union. There is no acceptable substitute fuel.
- Carefully prevent contaminants and water from entering the storage tank and fuel tank, and tighten the filler cap securely.
- When you clean the fuel tank, discharge deposits from the drain plug at the bottom of the fuel tank.

Ambient temperature	Specification
0 °C or over	Number 2-D of ASTM D-975 CEN EN590
Below 0 °C	Winder blend fuels (combinations of number 1-D and number 2-D of ASTM D-975) (*)

(*) Use ultra-low sulfur diesel only. Refer to the separate engine manual for details.

Maintenance Table

No.	Item		Points/ Quantity	Inspection and maintenance interval				
				Every day	250 h	500 h	600 h	1000 h
1	Fuel tank	Cleaning	1 point				●	
2	Engine fuel filter	Replace element	1 point			●		
3	Strainer	Inspect and clean	1 point			●		
4	Water separator	Replace element	1 point			●		
		Draining water	1 point					●(*1)

(*1): When the engine warning lamp lights up.

 The intervals of the inspection and maintenance for the engine fuel filter and strainer are for reference only. Refer to the separate engine manual for details.

 For replacing the element of the engine fuel filter, refer to the separate engine manual. For inspecting and cleaning of the strainer, contact a TADANO distributor or dealer.

Draining Water from Water Separator

CAUTION

The engine is very hot immediately after the operation, and you can suffer burns if you work around it. Before you start the work, let it cool down until you can touch it by bare hands.

NOTICE

When the engine warning lamp lights up, water may exist in the fuel filter. Drain the fuel filter. If you run the engine with water remaining in the filter, engine can cause malfunction.

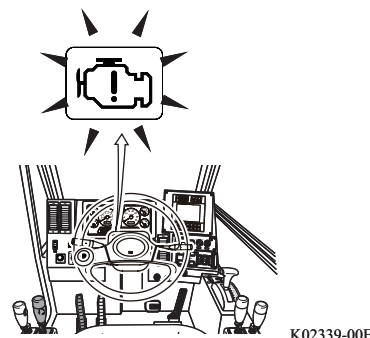

1. Stop the engine.
2. Wait until the engine cools down.
3. Place a pan to catch water under the fuel filter.
4. Turn the drain valve counterclockwise for 3 and half turns.
 - The valve pops down and water is drained out.
5. Raise the valve, turn it clockwise, and tighten it.

Right side of engine room

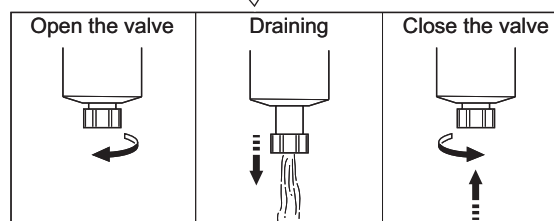
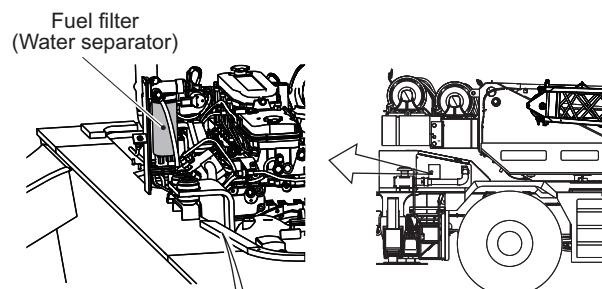

K07114-00E

Brake System

⚠ WARNING

- Do not use different brands of brake fluid together. Use different brands of brake fluid together can change the properties of the fluid and may have an adverse effect on the brake system and it may cause an accident. For brake fluid, use "TADANO" Genuine Brake Fluid".
- "TADANO Genuine Brake Fluid" is glycol-based. If a silicon- or mineral-based brake fluid is used, it will permeate the packing and cause the brakes to become ineffective, resulting in an accident. Always use "TADANO Genuine Brake Fluid".

NOTICE

Use unopened new brake fluid only for replenishment or replacement.

Maintenance Table

No.	Item		Points/ Quantity	Inspection and maintenance interval				
				1 week	100 h	300 h	600 h	1200 h
					1 month	3 months	6 months	1 year
1	Brake Fluid Reservoir	Replace brake fluid	Approx 0.45 gal (1.7 L)					●
2	Disk Brake Pad	Checking for Wear	6 point			●		
3	Air Dryer	Replace desiccating agent	1 point					●
4	Parking brake pad	Clearance Adjustment	1 point					●

Brake Fluid Reservoir

⚠ WARNING

The brake fluid has high moisture absorbing properties. Therefore, if you fail to replace of brake fluid for a long time, vapor lock can occur and cause an accident. Replace brake fluid at the specified intervals.

Replacing Brake Fluid

Contact your nearest TADANO distributor or dealer to replace brake fluid.

Disk Brake Pad

⚠ WARNING

- If you use the brakes whose pads are near their wear limit in their thickness, the disc plates can suffer damage and a brake failure can occur. It can cause an accident. If an inspection reveals that the pads are near their wear limit, stop use of the machine, and have the nearest TADANO distributor or dealer replace the pads immediately.
- Brake pads whose thickness is within working specifications can still be carbonized by heat build-up, worn unevenly or scratched. If the machine travels in this state, an accident can occur. If a scratch, abnormal wear or rust is discovered on the disk plates during inspection, have the nearest TADANO distributor or dealer inspect it.

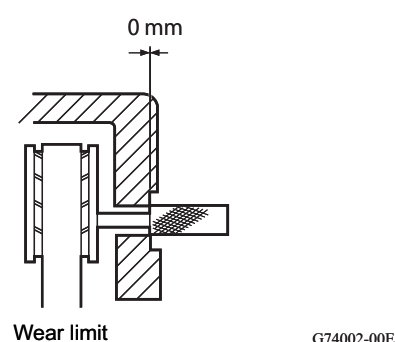
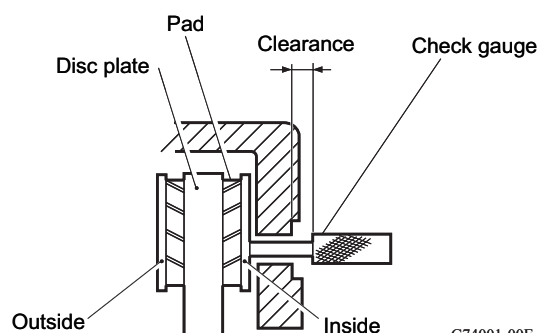

⚠ CAUTION

The calipers and disc plates are very hot immediately after traveling, and you can suffer burns if you work on them. Before you start the work, let them cool down until you can touch them by bare hands.

NOTICE

- You can use a check gauge for simple wear check although precise inspection requires removal of the pads.
Even when the inside of the pad has no significant wear, the outer face can wear away. Remove the pads at regular intervals to examine both inner and outer faces of the pads.
- Carry out pad wear inspection for all wheels. If the inspection shows that even 1 pad is worn to near its wear limit, remove all pads and inspect them. Replace the following parts as a set: all the pads, the pads of the right and left front wheels, or the pads of right and left rear wheels.

Checking for Wear

1. Extend the outriggers to the maximum and set up the machine.
2. Turn the steering wheel fully and insert the check gauge (provided) into the inspection hole of the caliper.

 Two inspection holes are provided for the front wheels, and a hole for the rear wheels.

3. If an inspection shows that there is no clearance between the caliper and the check gauge, the brake pad is at its wear limit. Replace the Pad.

Contact a TADANO distributor or dealer for replacement.

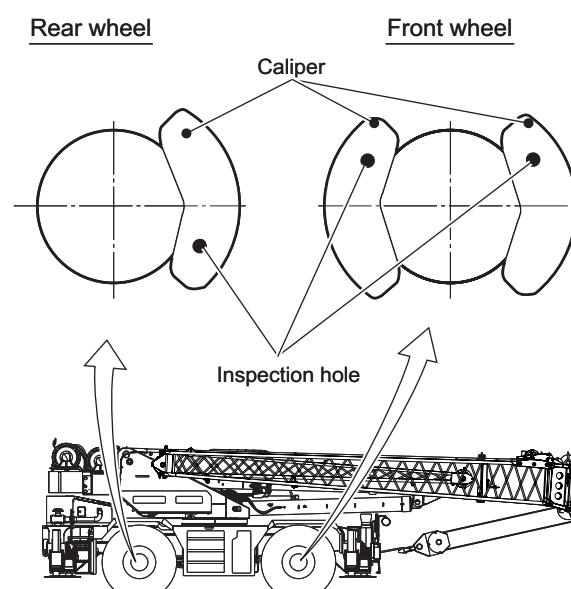

K07051-00E

Air Dryer

NOTICE

If the air dryer performance decreases, vapor contained in the compressed air condenses into water, and this has a bad effect on the equipment. Replace the desiccating agent at regular intervals.

Replacing the Desiccating Agent

Contact your nearest TADANO distributor or dealer for replacement of the desiccating agent.

 The air dryer is installed behind the air tank above the fuel tank.

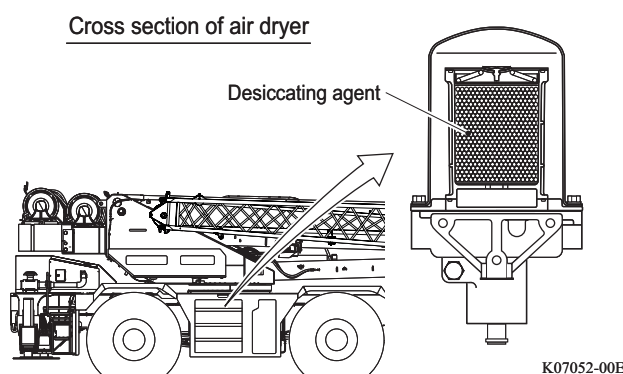

K07052-00E

Parking Brake Pad

⚠ WARNING

- If you use the brakes whose pads are near their wear limit in their thickness, the disc plates can suffer damage and a brake failure can occur. It can cause an accident. If an inspection reveals that the pads are near their wear limit, stop use of the machine, and have the nearest TADANO distributor or dealer replace the pads immediately.
- Brake pads whose thickness is within working specifications can still be carbonized by heat build-up, worn unevenly or scratched. If the machine travels in this state, an accident can occur. If a scratch, abnormal wear or rust is discovered on the disk plates during inspection, have the nearest TADANO distributor or dealer inspect it.
- If you use the parking brake as an emergency brake, the pads wear away rapidly. If you continue to use the parking brake with worn pads, the brake can fail to work and an accident can occur. After you use the parking brake as an emergency brake, inspect the pads.
- A parking brake pad comes to use limit when its remaining thickness becomes as small as 0.12 in. (3.0 mm) at any point on the circumference. Have the nearest TADANO distributor or dealer replace the pads.

⚠ CAUTION

The pads and disc plates are very hot immediately after using parking brake, and you may suffer burns if you touch them. Before you start the work, let them cool down until you can touch them by bare hands.

Clearance Adjustment

1. Extend the outriggers to the maximum and set up the machine.
2. Switch the parking brake switch to "OFF" and fully stretch the brake chamber rod.

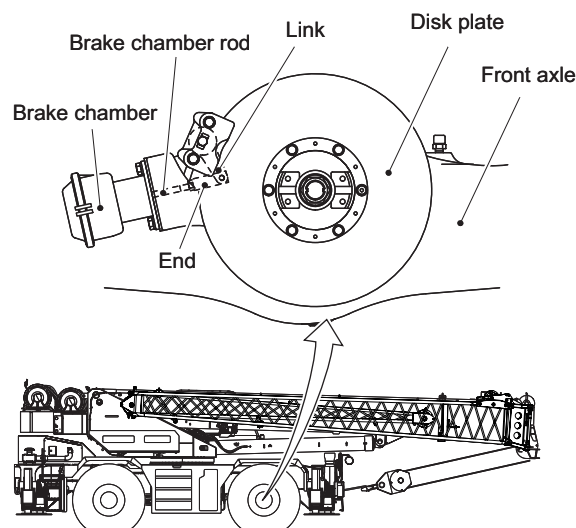

K07053-00E

3. Tighten the adjusting nut until the disk plate touches the pad.

Tightening torque	9.6 to 10.4 ft-lb {13.0 to 14.2 N•m}
-------------------	--------------------------------------

4. Turn back the adjuster nut by 120°.
- The clearance between the disc plate and each pad becomes 0.007 in. (0.20 mm).

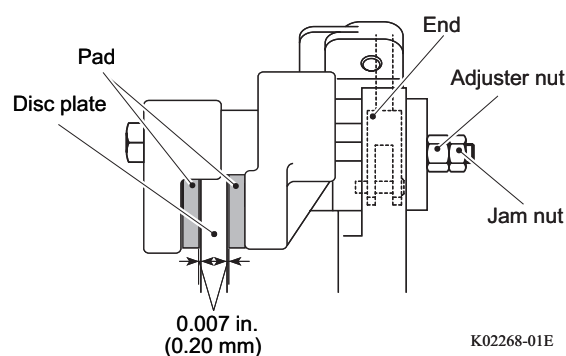

5. Check that the disc plate rotates smoothly.

⚠ WARNING

If the brake is used continuously while there is not enough clearance between the disc plate and the pads, it may result in excessive heat or an ignition.

Check the clearance between the disc plate and pads after adjusting clearance.

6. Tighten the jam nut while holding the adjuster nut.
- The adjuster nut is secured.

Tightening torque	45 to 55 ft-lb {61.0 to 74.6 N•m}
-------------------	-----------------------------------

⚠ WARNING

The lack of tightening torque may cause the jam nut to loosen and the brake to malfunction.

Tighten the jam nut securely.

Tire, Wheel

⚠ WARNING

If you replace or remount a tire and wheel in an incorrect manner, the wheel can come off or the tire can burst. It can cause an accident. Contact your nearest TADANO distributor or dealer for replacement and installation.

Maintenance Table

No.	Item		Points/ Quantity	Inspection and maintenance interval					
				1 week	100 h	300 h	600 h	1200 h	
					1 month	3 months	6 months	1 year	
1	Tire	Tire Rotation	4 points						●(*1)
2	Wheel Nut	Checking for Looseness	4 points			●(*2)			
3	Wheel parallelism	Check	—						●(*3)

(*1) Every 3,107 miles (5,000 km).

(*2) Make the first check after 31 miles (50 km) traveling or when replacing new tires, and succeeding checks after 62, 124, 311, and 621 miles (100, 200, 500, 1,000 km) travelings, and then every 3 months.

(*3) When wheels have suffered damage, contact your nearest TADANO distributor or dealer for inspection.

Tire

NOTICE

Long hours of traveling can wear the tire unevenly. Rotate the tires at regular intervals so that they wear evenly.

Tire Rotation

1. Slightly loosen the wheel nuts while the tires are in contact with the ground.
2. Extend the outriggers and raise the tires off the ground.
3. Remove the wheel nuts and remove the tires.
4. Clean the threads of the wheel nuts and wheel bolts.
Replace the wheel nuts and wheel bolts with damaged threads. Also replace the deformed or cracked wheels.

 Dirt on the threads can cause wheel nuts to loosen.

5. Mount the wheels with the wheel bolts aligned to the wheel bolt holes.

 For rotation, change the tire positions as shown in the figure.

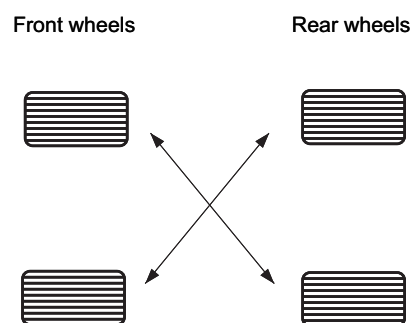

G75001-00E

6. Apply torque control agent or grease between the wheel nuts and washer, and on the threaded sections of the wheel bolts.

NOTICE

Do not use oil or grease which contains molybdenum disulfide. They can cause the wheel bolts to elongate.
Use a TADANO-designated torque control agent, or Daphne Eponex SR No. 2 or an equivalent.

7. Temporarily tighten the wheel nuts.
8. Retract the outriggers and lower the tires to the ground gently.
9. Tighten the wheel nuts with the specified tightening torque.
 Tighten the wheel nuts diagonally and alternately in the sequence shown in the illustration at the right.

Tightening torque	450 to 494 ft-lb (610 to 670 N•m)
-------------------	-----------------------------------

 A wheel has 20 wheel nuts.

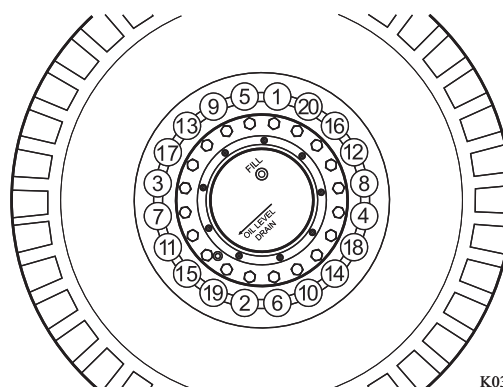

K03036-000

10. After a tire is replaced, tighten the wheel nuts again with the specified tightening torque after approximately 31 miles (50 km) of traveling.

Wheel Nut

⚠ WARNING

If a wheel nut is loose or tightened exceeding the specified torque, the wheel can come off or the wheel bolt can break. This can cause an accident. Examine them at regular intervals and re-tighten them with the specified torque.

Checking for Looseness

Examine looseness of the wheel nuts, and tighten them with the specified tightening torque.

Hydraulic system

⚠ WARNING

Never dismount or disassemble the hydraulic components, piping, and couplings. Even when the engine is not running, some components remain under high pressure. Careless dismounting or disassembling may cause serious injury or death.

⚠ CAUTION

The hydraulic oil and hydraulic components are very hot immediately after the operation, and you may suffer burns if you work on them. Let them cool down until they can be touched by bare hands before starting the work.

NOTICE

- Do not use different brands of hydraulic oil together. Using different brands of hydraulic oil together may change the properties of the oil and cause an adverse effect on the machine.
When you add hydraulic oil, use the same brand that is already used in the machine. If a different brand of hydraulic oil must be used, be sure to drain all the remaining hydraulic oil before adding the new oil.
- Do not operate the crane if the temperature of the hydraulic oil is beyond 176°F (80°C). If the hydraulic oil temperature is 176°F (80°C) or higher, it deteriorates fast and decreases the service life of the hydraulic components.
- The hydraulic oil is more viscous when its temperature is low. If the crane is operated without warming-up in cold weather for high-speed operation with load, it damages the hydraulic components. When the ambient temperature is low, do not start crane operation right away. Instead, let the crane warm up sufficiently with the engine running at slow speed until the oil temperature rises to approx. 68°F (20°C).
- Handle the hydraulic pipes carefully. If you handling these pipes incorrectly, it may cause the oil leaks or the hydraulic components to malfunction. Whenever a pipe has to be removed, request your nearest TADANO distributor or dealer.
- If dust, foreign matter, water etc., enter into the hydraulic oil tank or pipes, it may cause a machine failure. Pay sufficient attention to keep these parts from dust when working on them.

Maintenance Table

No.	Item		Points/Quantity	Inspection and maintenance interval							
				100 h	300 h	600 h	1200 h	2400 h	4800 h		
				1 month	3 months	6 months	1 year	2 years	4 years		
1	Hydraulic oil tank	Hydraulic oil	Replacing	Approx. 221 gal (837 L) (*1) Approx. 288 gal (1,090 L) (*2)							● (*3)
		Return filter	Replacing	1 point				●			
		Air breather	Replacing	1 point			●				
2	Return filter (front of the hydraulic tank)	Replacing	1 point				●				
3	Line filter (Steering/swing pump circuit)	Replacing	1 point				●				
4	Line filter	Winch brake circuit	Clean	1 point					●		
		Source of upper pilot pressure	Clean	1 point					●		
		Steering mode changeover circuit	Clean	1 point					●		
		Low pressure warning circuit	Clean	1 point					●		
		Automatic stop circuit	Clean	2 points					●		
		Pilot valve for swing/auxiliary winch/boom telescoping	Clean	1 point					●		
		Pilot valve circuit for main winch/boom elevation	Clean	1 point					●		
		Steering circuit	Clean	1 point					●		
		Pilot valve circuit for boom elevation pedal/telescoping pedal	Clean	1 point					●		
		Swing circuit	Clean	2 points					●		
		Changeover in upper structure pilot pressure	Clean	1 point					●		
		Telescoping changeover circuit	Clean	2 points					●		
		Jib control valve circuit	Clean	1 point					●		
Elevation proportional valve circuit	Clean	2 points					●				

(*1): Tank capacity (*2): Total oil capacity

(*3) 2400 h or 2 years when non Tadano hydraulic oil LL is used

 For the replacement/cleaning of line filter No. 4, contact your nearest TADANO distributor or dealer.

 For brands of hydraulic oil, refer to "Oils and Greases" (page 451).

Hydraulic Oil Tank

NOTICE

You must bleed air remaining on the suction side of the hydraulic pump after the hydraulic oil replacement. Starting the hydraulic pump without bleeding air damages the pump. After replacing the oil, do not attempt to start the pump until the air is bled. For the bleeding procedure, contact your nearest TADANO distributor or dealer.

Replacing Hydraulic oil

When replacing the hydraulic oil, also replace the return filter.

1. Set the machine into the traveling configuration, and set it up on a level ground.
2. Remove the cover from the filler port and use an oil pump to drain the hydraulic oil from the tank into an oil drum or other suitable container.

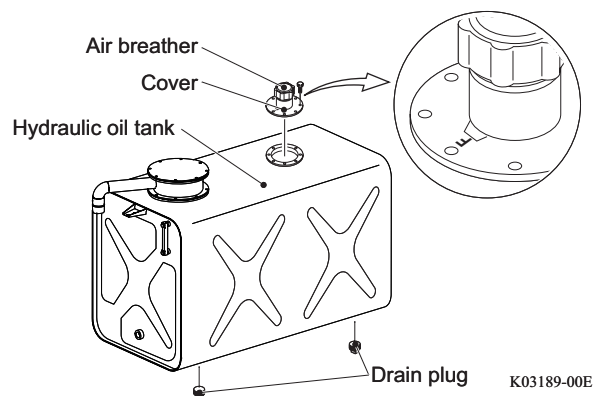

3. Remove the drain plug at the bottom of the tank to release any remaining hydraulic oil.
4. Check the inside of the tank, and clean if any dust or foreign matter is found.
5. Clean the drain plug and wrap a sealing tape around it, then tighten the plug.
6. While watching the oil level in the oil level gauge, add new hydraulic oil into the tank.
7. Remount the cover on the hydraulic oil tank so as the "F" mark on the hydraulic tank cover to face the front of the machine.
8. Bleed the hydraulic oil pump.
9. Check the oil level again. If low, add more hydraulic oil.

Replacing the Return Filter

1. Remove the top cover on the hydraulic oil tank and take out the return filter.

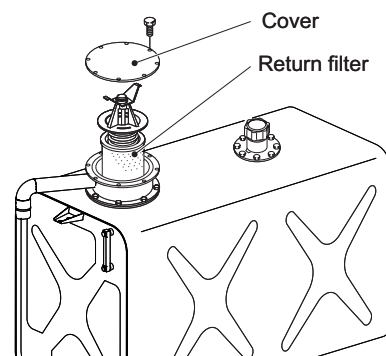

K03190-00E

2. Pull out the retaining pin and then remove the nut from the return filter.
3. Replace the filter element with a new one and reassemble the return filter.
4. Install the return filter in the tank and remount the cover.

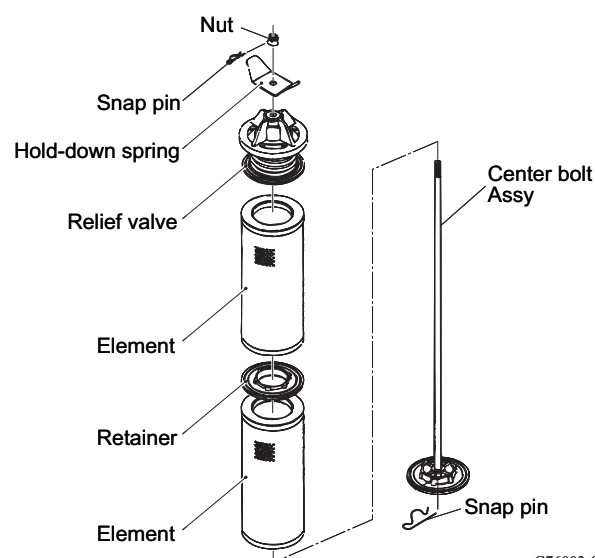

G76003-01E

Replacing Air Breather

Loosen the bolts and remove the element holder.
Replace the element with a new one.

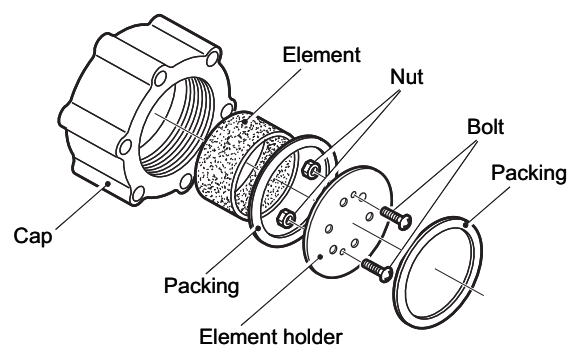

G76004-00E

Return Filter (Front of Hydraulic Tank)

Replacement

1. Remove the filter cartridge using a strap wrench.

 Place a rag beforehand to catch the hydraulic oil which may spill when the filter cartridge is removed.

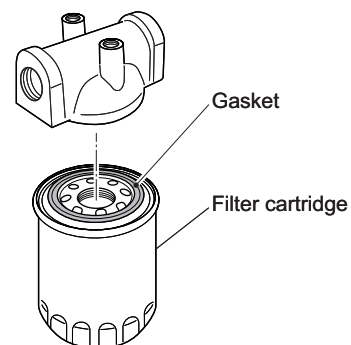

2. Apply hydraulic oil thinly to the gasket and then install a new filter cartridge. Tightening torque: 14.8 ft-lb {20 N•m}

G76005-02E

Line Filter (Steering, Swing Pump Circuit)

Replacing

1. Set up the machine on a level ground and stop the engine.
2. Remove the drain plug of the line filter and drain out the oil.

 There is approx. 0.4 gal (1.5 L) of the oil in the case.

3. Remove the case.
4. Take out the filter element from the head.
5. Mount a new filter element on the head.

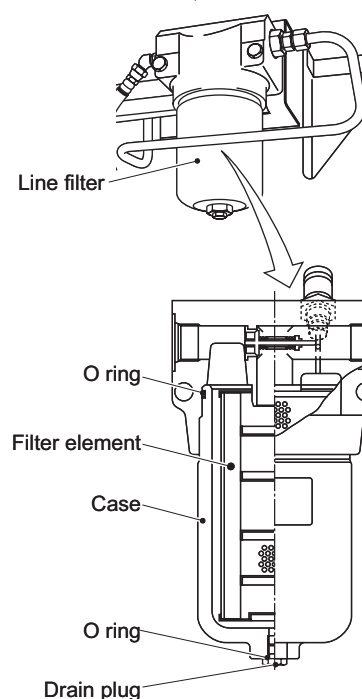
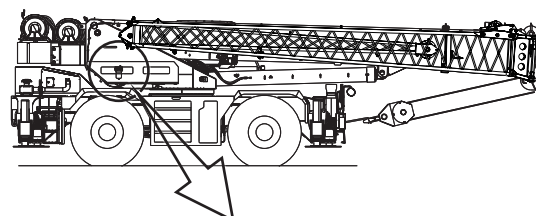

K07059-00E

6. Apply a thin coat of hydraulic oil to the O-ring, and mount the case.

Tightening torque: 74 ft – lb {100 N·m}

 Replace the O-ring with a new one.

7. Apply a thin coat of hydraulic oil to the O-ring, and mount the drain plug.

Tightening torque: 29.6 ft – lb {40 N·m}

 Replace the O-ring with a new one.

8. Start the engine to bleed air from the line filter.

⚠ WARNING

Bleed air from the line filter. Air in the line filter will cause the lag in the wheel operation when the steering wheel is turned. This can cause an accident.

9. Stop the engine.

Swing System

Maintenance Table

No.	Item	Points/ Quantity	Inspection and maintenance interval					
			1 week	100 h	300 h	600 h	1200 h	
				1 month	3 months	6 months	1 year	
1	Swing Bearing Mounting Bolt	Checking 48 bolts on inner ring 47 bolts on outer ring		●			●	

Swing Bearing Mounting Bolt

⚠ WARNING

The regular checking is required for the swing bearing mounting bolts because they can sometimes come loose or be elongated.

If the machine is operated while the swing bearing mounting bolts have any abnormalities, the bolts can break off and cause the upper structure to come apart from the lower structure. This can result in a serious accident.

Be sure to check the mounting bolts periodically to prevent such an accident.

Checking

Examine the tightening torque for the swing bearing mounting bolts.

Inspect the bearing inner ring bolts one by one while you swing the boom.

Tightening torque (bearing inner ring bolts)	1195 to 1335 ft-lb {1620 to 1810 N•m }
Tightening torque (bearing outer ring bolts)	868 to 940 ft-lb {1177 to 1275 N•m}

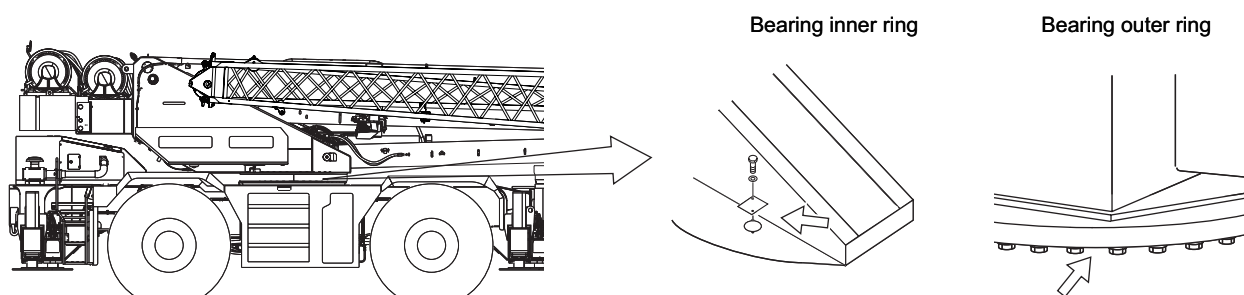

K07060-00E

Checking the swing bearing inner ring

1. Remove the inspection cover.

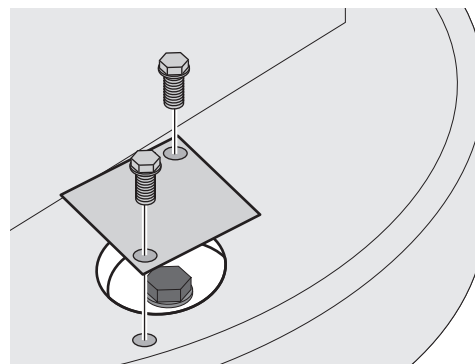

K04055-000

2. Swing the boom so as the swing bearing mounting bolts to come in the center of the inspection hole, and check the looseness of the bolts

Inspect every 100 working hours or every 1 month

Check the swing bearing mounting bolts for any abnormalities (looseness, elongation, rusting, breakage, or dropping off). For the looseness and elongation of the bolts, visually check the gap between the bolt and mounting surface. Also, check the looseness using a test hammer.

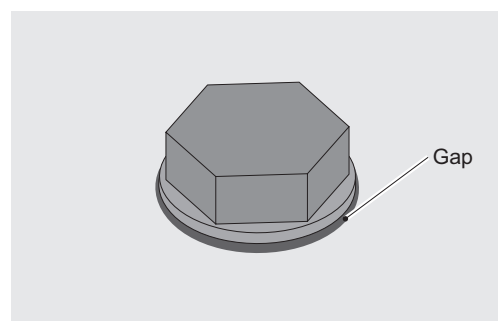

K02552-00E

Inspect every 1200 working hours or every 1 year

Check the swing bearing mounting bolts for any abnormalities (looseness, elongation, rusting, breakage, or dropping off).

Also, have the tightening torque checked using a torque wrench by your nearest TADANO distributor or dealer.

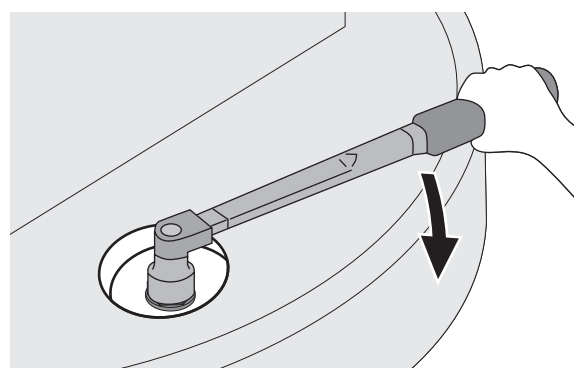

K02553-000

If any abnormalities are found

If any one of the bolts has abnormalities other than looseness, have all the bolts replaced by your nearest TADANO distributor or dealer.

When the bolts are replaced, make sure that the torque control agent is applied to the threaded area of the bolts, and the bolts are tightened to the specified torque.

3. After checking is completed, remount the inspection cover.

Checking the swing bearing outer ring

Check the swing bearing mounting bolts for any abnormalities (looseness, elongation, rusting, breakage, or dropping off). The requirements of the check are similar to those of the swing bearing inner ring.

Electrical System

Maintenance Table

No.	Item	Points/ Quantity	Inspection and maintenance interval			
			1 week	100 h	300 h	600 h
				1 month	3 months	6 months
1	Fuse Replacement		When fuse is blown			

Replacing Fuses

NOTICE

- To prevent short-circuit, set the starter switch to "OFF", and remove the cable from the negative terminal of the battery before fuse replacement.
- Using a fuse exceeding the rated capacity can burn out wiring or electrical components in case of short-circuit.
Use a fuse with the specified capacity for replacement.
- If a fuse is blown again even after the replacement, other causes are conceivable.
Contact your nearest TADANO distributor or dealer for inspection.

Upper Structure (For up to Serial No.548092)

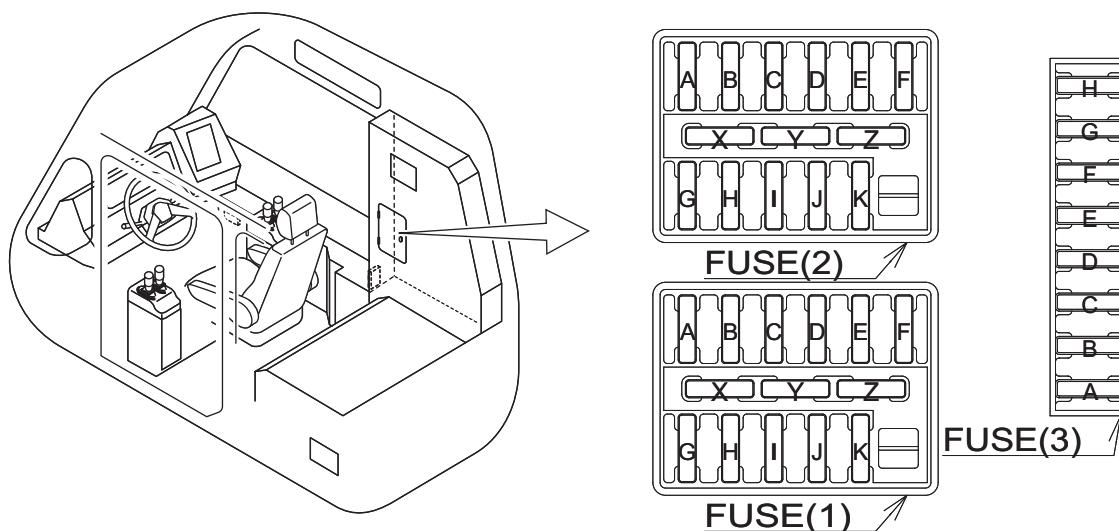

FUSE1

POSITION	CAPACITY	No.	COLOR	OBJECT
A	5A	213	L	MULTIPLX DATA TRANSMITTER
B	5A	154	L/B	PTO SWITCH
C	15A	156	L/W	POWER SOURCE FOR CRANE(STD)
D	10A	254	L/G	POWER SOURCE FOR CRANE(EMERGENCY)
E	15A	152	L/Y	WORKING LAMP
F	10A	238	L/R	AIR CONDITIONER
G	10A	144	G	PARKING BRAKE
H	10A	157	G/B	STEERING SELECT OUTRIGGER CONTROL COMBINATION SWITCH LEVEL INDICATOR FOR DPE-DFP SWITCH HI BEAM SELECT HI-LO DRIVING SHIFT EXHAUST BRAKE
I	10A	750	G/W	COMBINATION METER
J	15A	151	G/R	CIGAR LIGHTER
K	15A	218	G/Y	POWER WINDOW
X	5A	-	-	SPARE
Y	10A	-	-	SPARE
Z	15A	-	-	SPARE

FUSE2

POSITION	CAPACITY	No.	COLOR	OBJECT
A	5A	820	L	POWER SOURCE FOR CRANE(AML)
B	5A	234	L/B	AIR CONDITIONER
C	15A	225	L/W	AIR CONDITIONER
D	10A	-	L/G	RESERVE
E	15A	845	L/Y	POWER SOURCE FOR CRANE(STD)
F	10A	226	L/R	AIR CONDITIONER
G	10A	-	G	RESERVE
H	10A	214	G/B	T/M SHIFT SELECT EMERGENCY T/M SWITCH EMERGENCY ACCELERATOR SWITCH
I	10A	155	G/W	HEAD LAMP/AIR HORN AIR BUZZER
J	15A	150	G/R	FRONT WINDSHIELD WIPER
K	15A	158	G/Y	WASHER/ROOF WINDSHIELD WIPER
X	5A	-	-	SPARE
Y	10A	-	-	SPARE
Z	15A	-	-	SPARE

FUSE3

POSITION	CAPACITY	NO	COLOR	OBJECT
H	10A	159	W/R	POWER SOURCE FOR CRANE(PTO) SELF-REMOVING COUNTER WEIGHT
G	5A	-	Y/R	RESERVE
F	5A	327	R/Y	POWER SOURCE FOR CRANE(STD)
E	5A	-	G	RESERVE
D	5A	-	L	RESERVE
C	10A	-	W	RESERVE
B	5A	-	Y	RESERVE
A	10A	-	R	RESERVE

343-977-91050

K02972-00E

GR-750XL-2_OM2(U)-17E

Upper Structure (For Serial No.548093 and after)

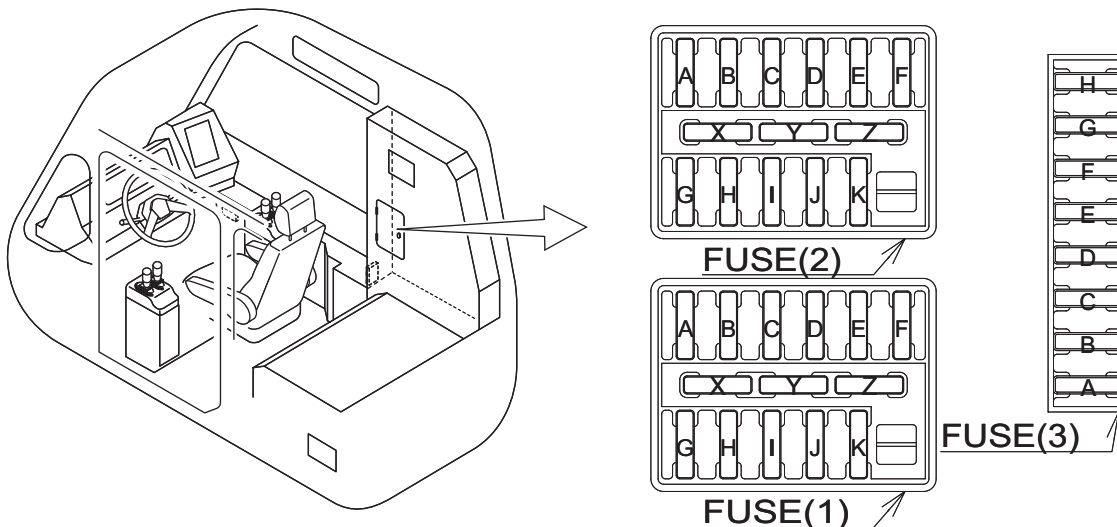

FUSE1

POSITION	CAPACITY	No.	COLOR	OBJECT
A	5A	213	L	MULTIPLEX DATA TRANSMITTER
B	5A	154	L/B	PTO SWITCH
C	15A	156	L/W	POWER SOURCE FOR CRANE(STD)
D	10A	254	L/G	POWER SOURCE FOR CRANE(EMERGENCY)
E	15A	152	L/Y	WORKING LAMP
F	10A	238	L/R	AIR CONDITIONER
G	10A	144	G	PARKING BRAKE
H	10A	157	G/B	STEERING SELECT, OUTRIGGER CONTROL, COMBINATION SWITCH, OVER SPEED LIMITER, LEVEL INDICATOR FOR DPE, DPF SWITCH, HI BEAM SELECT, HI-LO DRIVING SHIFT, EXHAUST BRAKE
I	10A	750	G/W	COMBINATION METER
J	15A	151	G/R	CIGAR LIGHTER
K	15A	218	G/Y	POWER WINDOW
X	5A	-	-	SPARE
Y	10A	-	-	SPARE
Z	15A	-	-	SPARE

FUSE2

POSITION	CAPACITY	No.	COLOR	OBJECT
A	5A	820	L	POWER SOURCE FOR CRANE(AML)
B	5A	234	L/B	AIR CONDITIONER
C	15A	225	L/W	AIR CONDITIONER
D	10A	-	L/G	RESERVE
E	15A	845	L/Y	POWER SOURCE FOR CRANE(STD)
F	10A	226	L/R	AIR CONDITIONER
G	10A	-	G	RESERVE
H	10A	214	G/B	T/M SHIFT SELECT, EMERGENCY T/M SWITCH, EMERGENCY ACCELERATOR SWITCH
I	10A	155	G/W	HEAD LAMP, AIR HORN, AIR BUZZER
J	15A	150	G/R	FRONT WINDSHIELD WIPER
K	15A	158	G/Y	WASHER, ROOF WINDSHIELD WIPER
X	5A	-	-	SPARE
Y	10A	-	-	SPARE
Z	15A	-	-	SPARE

FUSE3

POSITION	CAPACITY	NO	COLOR	OBJECT
H	10A	159	W/R	POWER SOURCE FOR CRANE(opt), SELF-REMOVING COUNTER WEIGHT
G	5A	-	Y/R	RESERVE
F	5A	327	R/Y	POWER SOURCE FOR CRANE(STD)
E	5A	-	G	RESERVE
D	5A	-	L	RESERVE
C	10A	-	W	RESERVE
B	5A	-	Y	RESERVE
A	10A	1080	R	POWER SOURCE FOR CRANE (opt)

343-977-91050-2

K02972-02E

Lower Structure

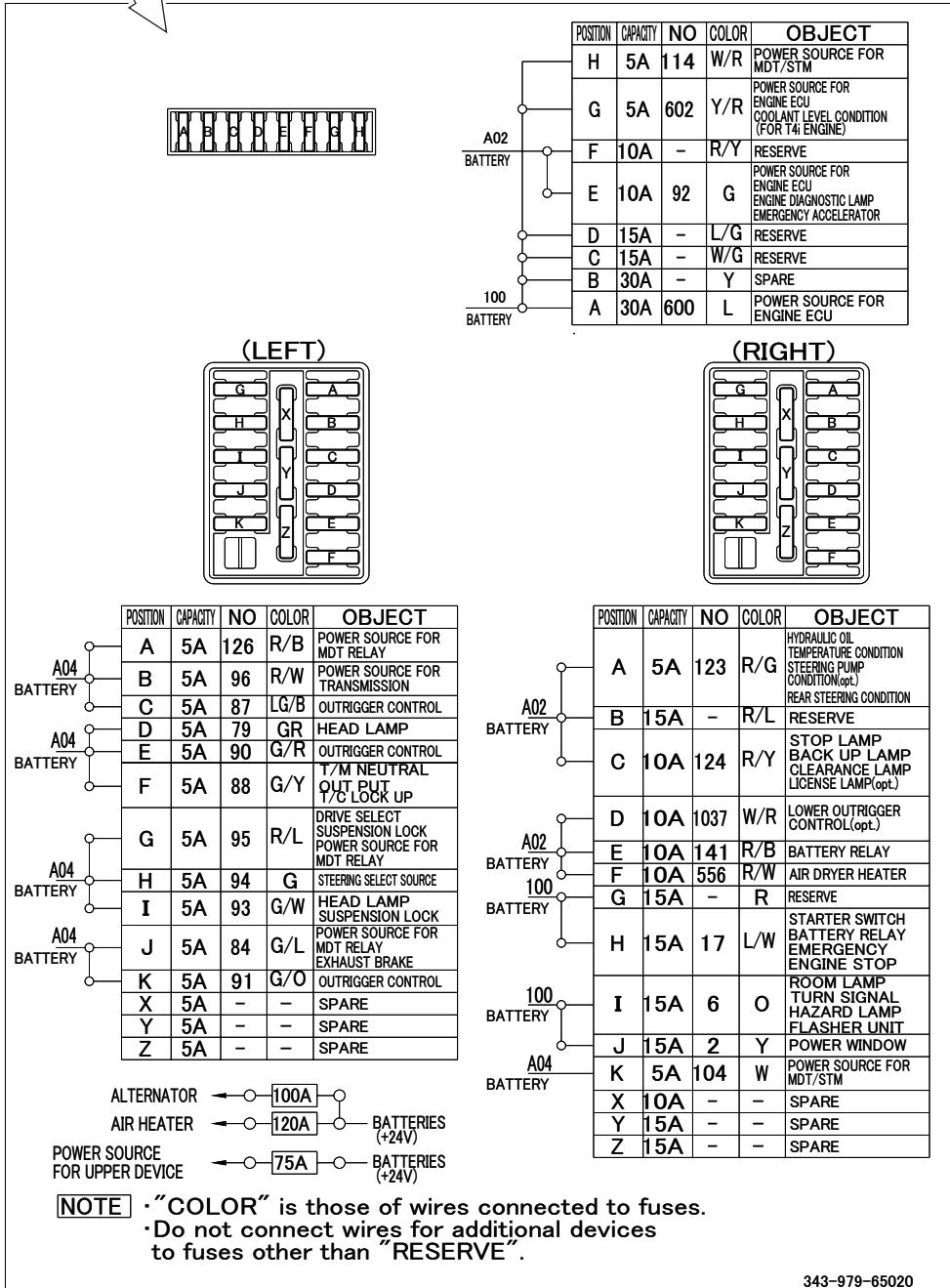
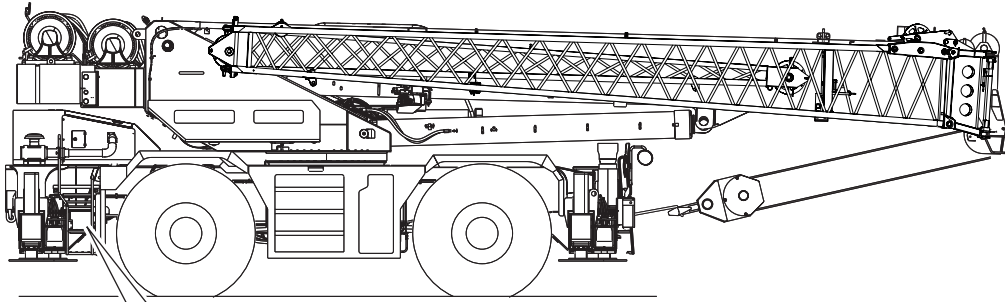

343-979-65020

343-979-65020-2

K07061-00E

GR-750XL-2_OM2(U)-17E

Air Conditioner System

Maintenance Table

No.	Item	Points/ Quantity	Inspection and maintenance interval					
			100 h	300 h	600 h	1200 h	2400 h	4800 h
			1 month	3 months	6 months	1 year	2 years	4 years
1	Condenser	Check, Cleaning				●		
2	Refrigerant level	Check				●		
3	Refrigerant piping connection	Check				●		
4	Inside air filter	Check, Cleaning			●			
5	Outside air filter	Replacing					●	
6	V-belt	Check		●				

Condenser

Check, Cleaning

Open the cover on the left side of the machine.
Wash away mud, dust and others stuck to the fins of the condenser.

CAUTION
Before you wash the condenser, stop the engine. Otherwise, an electric shock can occur.

NOTICE
Do not use detergent. It can cause a unit failure.

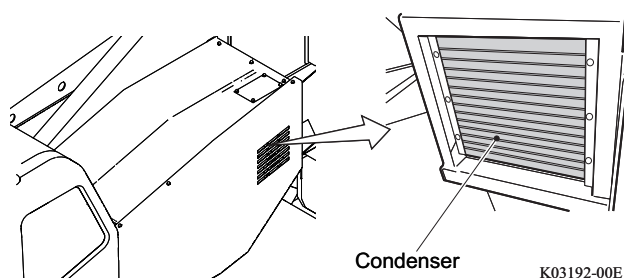

K03192-00E

Refrigerant Level

Check

1. Set the air conditioner switch to "ON".
2. Open the inspection cover on the upper left side of the machine.
3. Look into the sight glass, and examine the condition of bubbles.

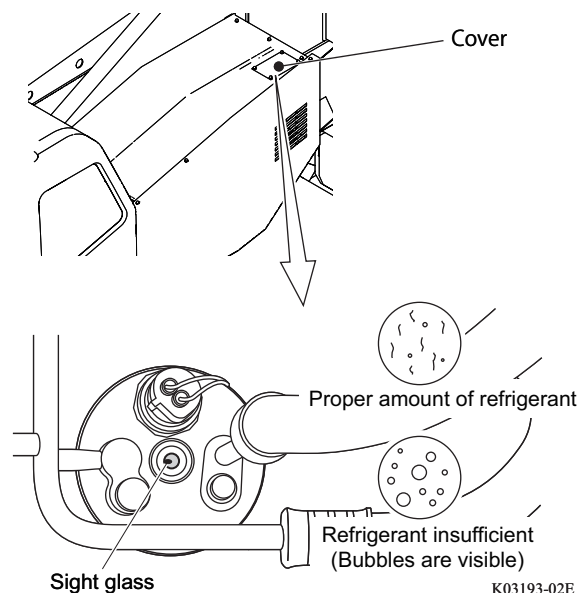

K03193-02E

Refrigerant Piping Connection

Check

Open the cover on the left side of the machine, and inspect the refrigerant piping connection for seeping oil.

NOTICE

If seeping of oil is significant, the gas can be leaking out of the connection. Contact a TADANO distributor or dealer for inspection and maintenance.

Inside Air Filter

Check, Cleaning

1. Open the inside air filter inspection cover at the rear of the crane operator's seat, and remove the inside air filter.
2. Removing ordinary soiling
Remove the inside air filter, and blow the clean compressed air through it from the side without dust.

Removing severe soiling

Soak and wash the filter in the lukewarm water with mild detergent. Then rinse it with clear water, and air-dry it completely.

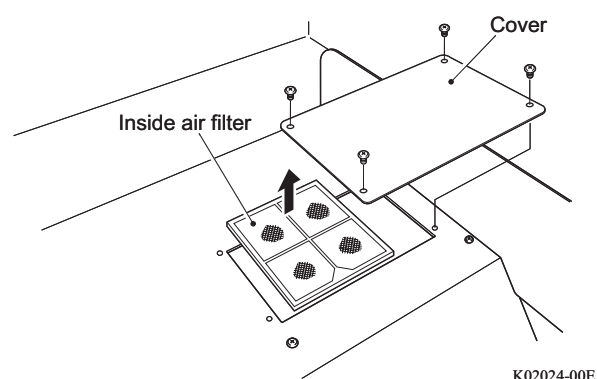

Outside Air Filter

Replacing

1. Open the outside air filter inspection cover at the rear side of the crane operator's seat. Then remove the outside air filter.
2. With attention to the arrow mark on the top of the filter, attach a new filter.

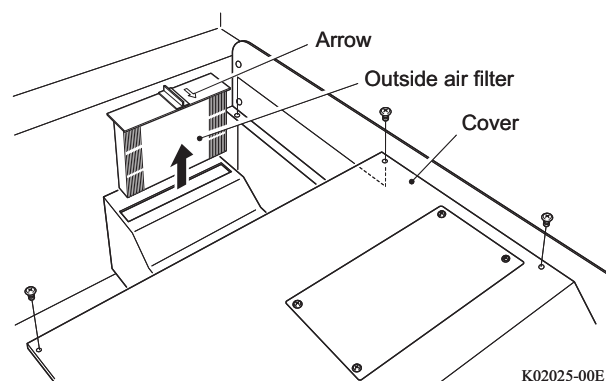

V-belt

Check

Open the cover on the left side of the machine, and examine the belt tension and presence of damage

NOTICE
<ul style="list-style-type: none"> • After adjustment, securely tighten bolts and nuts. • Do not tighten the belt excessively. Otherwise, the belt and bearing can suffer damage. • Do not lubricate the belt. Oil and greases on the belt cause the belt slip and decrease the service life of the belt.

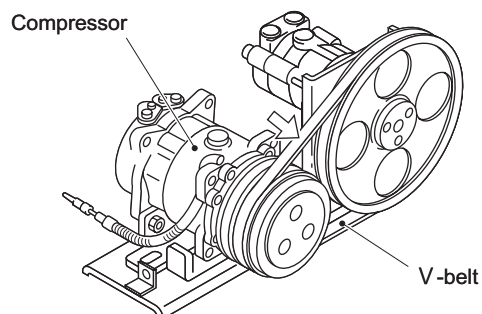

K02026-00E

Check method	Deflection when the center of the belt is pushed by approx. 22 lbs (10 kgf) of force	Belt tension gauge
At checking	0.39 to 0.47 in. (10 to 12 mm)	44.1 to 77.2 lbs (20 to 35 kgf)
At new belt installation	0.2 to 0.23 in. (5 to 6 mm)	99.3 to 121.2 lbs (45 to 55 kgf)

Periodic Replacement Part

To use the air conditioner system safely, replace the parts in the list below at regular intervals. Contact a TADANO distributor or dealer for replacement.

Periodic replacement part	Replacement interval
Receiver dryer	Every 4 years
Blower motor	Every 2 years
Electric fan motor	Every 2400 hours

Wire Rope

Replacing Wire Ropes

⚠ CAUTION

- Do not handle wire ropes with bare hands, or you can suffer an injury. When you handle wire ropes, always wear protective leather gloves.
- When you replace the wire ropes, wear protective gears. A jumping wire rope can hit and hurt you.

Criteria for Wire Rope Replacement

⚠ WARNING

If a wire rope breaks during operation, the load or hook block drops and causes a serious accident. Inspect the wire ropes at regular intervals. Immediately replace wire ropes that reach the criteria for replacement.

Perform daily and periodic (monthly) inspections of the wire ropes for breaks, wear, corrosion, deformation, damage due to sparks, or heat effects, lubrication, and rope end condition. If any of the conditions that follow exist, replace the wire rope.

If the end of wire rope is not in good condition, repair it or cut it short.

- In running ropes: six or more randomly distributed broken wires in one lay, or three or more broken wires in one strand in one lay.
- In standing ropes: more than two broken wires in one lay in sections beyond end connections, or more than one broken wire at an end connection.
- Wear of one-third of the original diameter of outside individual wires.

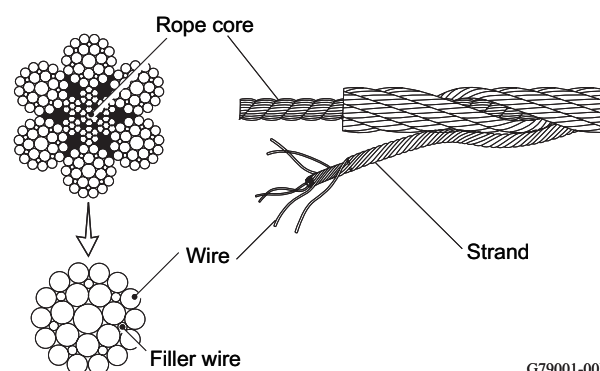

G79001-00E

 The figure shows the standard 6-strand wire rope.

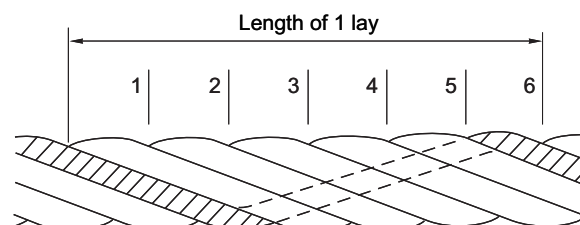

G79002-00E

- Reductions from nominal diameter of more than:

Nominal diameter of Wires	Wear Limits
to 5/16 in. (to 8.0 mm)	1/64 in. (0.4 mm)
3/8 to 1/2 in. (9.5 to 12.7 mm)	1/32 in. (0.8 mm)
9/16 to 3/4 in. (14.3 to 19.0 mm)	3/64 in. (1.2 mm)
7/8 to 1-1/8 in. (22.2 to 28.6 mm)	1/16 in. (1.6 mm)
1-1/4 to 1-1/2 in. (32.0 to 38.0 mm)	3/32 in. (2.4 mm)

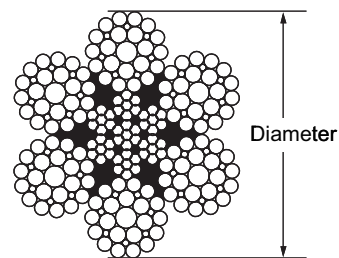

G79003-00E

- Evidence of kinking, crushing, bird caging, or any other damage resulting in distortion of the rope structure.
- Evidence of any heat damage from any cause.

Removing the Wire Rope

1. Extend the outriggers, and swing the boom to the rear or to the side.
2. Lower the boom fully, and put the hook block on the ground.

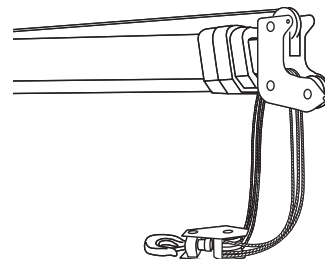

K00523-000

3. Remove the rope socket from the hook block or boom top end.
4. Remove the wire clip. Hammer out the wedge from its position. And then remove the wire rope from the rope socket.

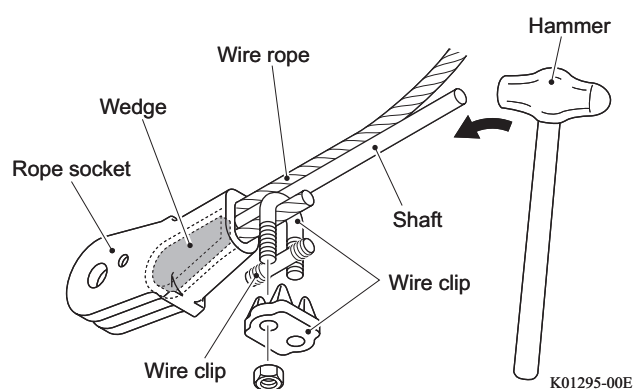

K01295-00E

5. Pull the wire rope out of the hook block and weight for overwind cutout device.
6. Unwind the winch while you pull the wire rope, and wind the wire rope around a wooden spool.

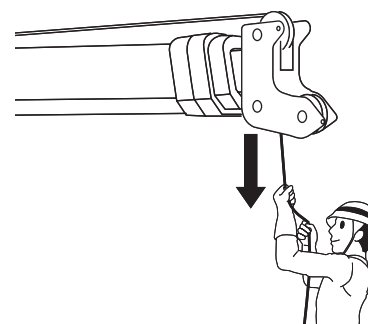

K00524-000

7. Wind in the wire rope until there is no wire rope left on the winch drum. Hammer out the wedge from the winch drum, and wind up all remaining wire rope.

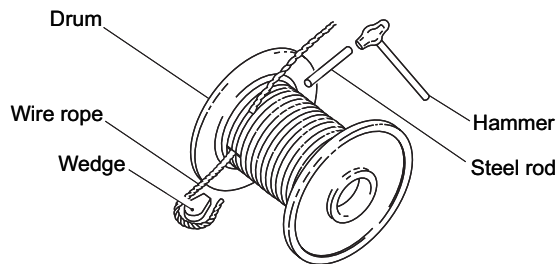

G79008-00E

Unwinding a Wire Rope

Wire rope is wound as a coil or wound on a wooden spool when supplied. Unwind the wire rope by rolling the coil, or pull out the rope while you turn the spool. If the wire rope is unwound improperly, it can become twisted, untwisted, or have kinks, rendering it unusable. Even a twist not so significant can cause the wire rope to become tangled.

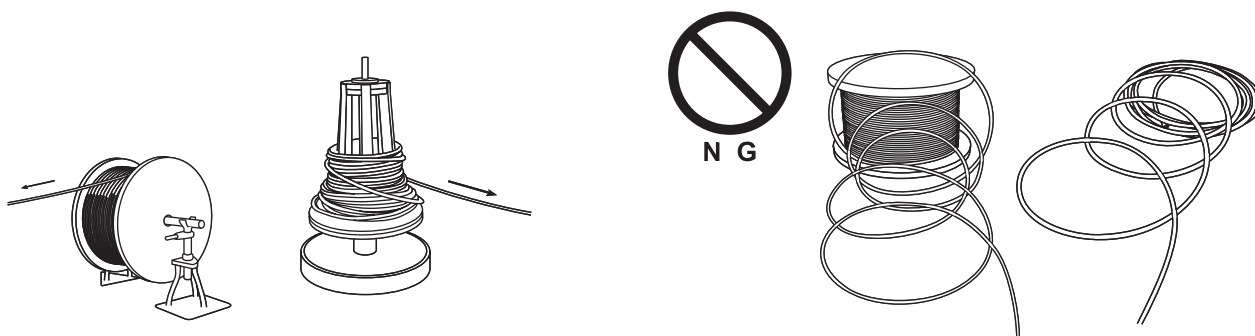

G79009-00E

Installing a Wire Rope

When you cut or end-treat the wire rope, apply seizing to the wire to prevent the strands from coming loose. For seizing, use a galvanized steel wire and wrap it around the wire rope tightly. The proper width of the seizing is 2 or 3 times the diameter of the rope.

Wire Rope Diameter	Seizing Wire Diameter
to 0.39 in. (to 10 mm)	0.024 to 0.047 in. (0.6 to 1.2 mm)
0.43 to 1.18 in. (11 to 30 mm)	0.039 to 0.079 in. (1.0 to 2.0 mm)

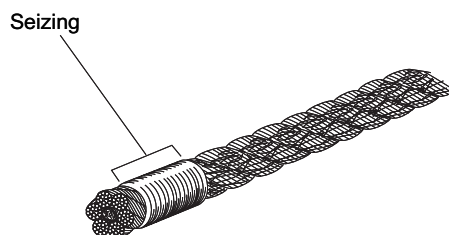

G79010-01E

1. Reeve a new wire rope through from the boom head or jib head to the winch drum.

NOTICE

Make sure that the routing of the wire rope is correct.

2. Secure the end of the wire rope to the winch drum.

NOTICE

Orient the wedge correctly. Make sure that the end of the wire rope does not protrude from the winch drum spool.

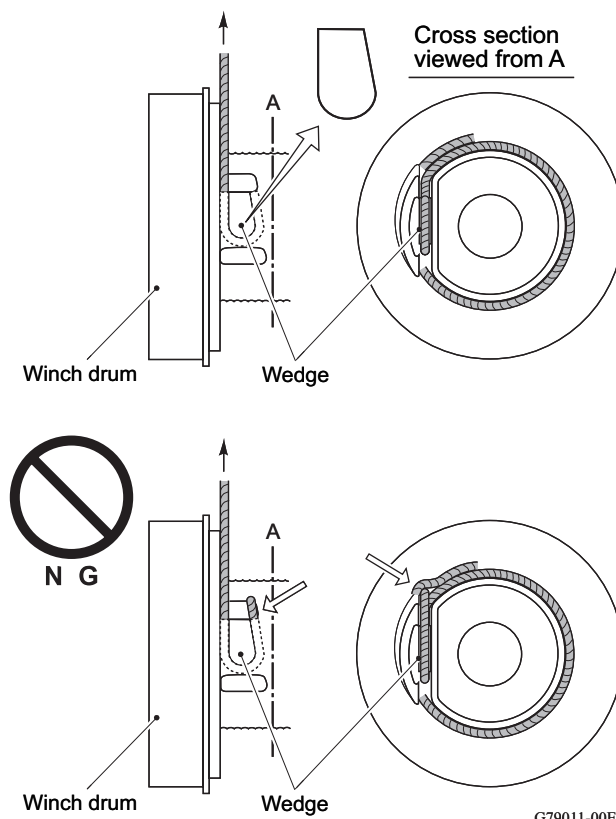

G79011-00E

3. Wind up the winch to wind the wire rope around the drum until a length only sufficient for attaching it to the hook block is left.

Pay attention to the following when winding the rope.

- At the start of the winding, wind the rope along the guide at the verge of the drum.
(See Fig. 1)
- For the first layer of winding, put the rope in the grooves on the drum.
- When you wind over another layer of windings, set the rope in the valleys between the ropes.
(See Fig. 2)

Fig. 1

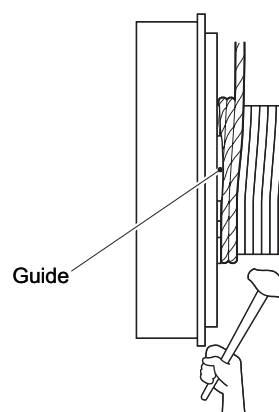
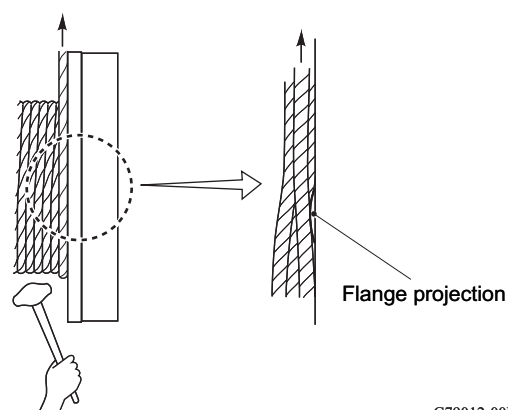



Fig. 2



G79012-00E

4. After you reeve the rope through the boom and hook block sheaves in the pattern appropriate to the number of parts of line, pass it through the weight for anti-twoblock device.

 For information on how to reeve the wire rope, refer to "Reeving the Wire Rope" (page 227).

5. Pass the wire rope through the rope socket, and secure it with the wire clip.

NOTICE
Pay attention to the orientations and positions of the wedge and wire clip installation.

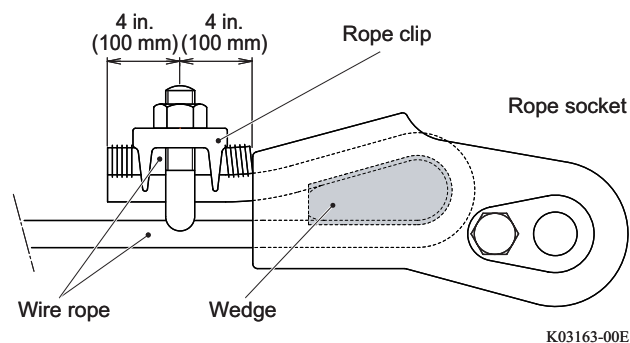

6. Insert the lock pin and secure the rope socket to the hook block or boom head.

WARNING

Securely tighten the fixing pin mounting bolt for the rope socket using a wrench. Improper installation can cause the rope socket to come off and the lifted load to fall. This can cause an injury.

To attach the rope socket to the right of the boom

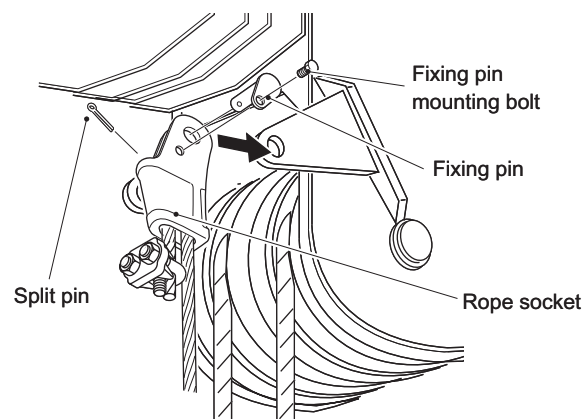

To attach the rope socket to the left of the boom

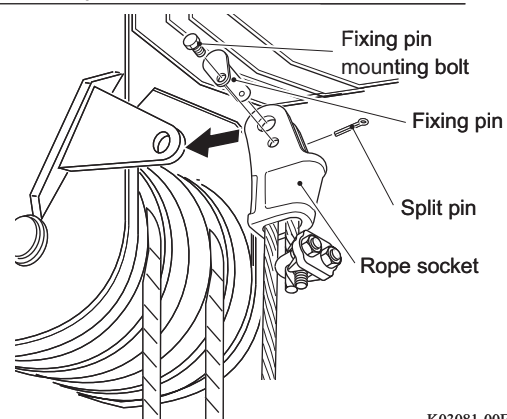

K03081-00E

After Replacement of the Wire Rope

A new wire rope is prone to disorderly winding. If the wire rope is wound disorderly, unwind and wind it again. When you bring a new wire rope into use, lift a light load at a low speed to settle the rope. This practice helps prolong the life of the wire rope.

When the wire rope is replaced, the new wire rope wound around the winch drum does not have the correct tension. If a load is hoisted up with the rope in this condition, the outer rope layer digs into the inner layer. This deforms the wire rope or causes disorderly winding, cut wires, etc. Before you lift a load, unwind the wire rope and apply the proper tension to it while you wind it again in the procedures that follow.

1. Extend the boom, and unwind the wire rope leaving 3 or some more dead turns of the rope on the winch drum.
2. Lift a load of approximately one third of the allowable load per wire rope to provide tension to the wire rope, and then wind the rope tightly around the winch drum.

Handling Wire Ropes

CAUTION

Do not handle wire ropes with bare hands, or you can suffer an injury. When you handle wire ropes, always wear protective leather gloves.

Always handle wire ropes with sufficient care. The life of wire ropes is maximized if they are handled correctly. If handled improperly, wire ropes can become unusable, or must be replaced prematurely. Handle the wire ropes correctly.

Disentangling the Wire Rope

If a new wire rope is used with a long boom and when the number of parts of line is small, the rope can become tangled. This condition is dangerous because it causes the hook block or a load to rotate. Correct this condition in the procedure described below.

1. Unwind the wire rope to the maximum length with 3 or some more dead turns of the rope left on the winch drum, and examine the direction and number of turns.
2. Stand the hook block on the ground, and slacken the wire rope.
3. Remove the rope socket from the boom or hook block, make a correction as described below, and then reattach the rope socket.
 - Right-hand turns: Twist the rope further by the number of turns.
 - Left-hand turns: Untwist the rope by the number of turns.

(1) Rope with right-hand turns viewed up from the hook block



(2) Rope with left-hand turns viewed up from the hook block



G79014-01E

NOTICE

Do not twist or untwist the rope 5 turns or more at a time.

4. Hoist the hook block up and down several times to make the twist even throughout the rope. If twists still remain after this, correct again.

NOTICE

If there are many twists, correct the rope step by step several times.

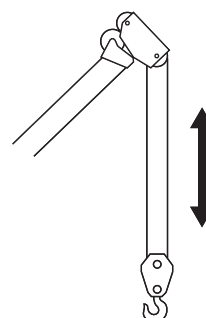

G79015-000

5. Make sure that the wire rope is not wound up disorderly on the winch drum.
If the wire rope is wound up disorderly, unwind and wind it again.

Eliminating Excessive Twisting of Wire Rope

<i>NOTICE</i>
<p>If operation is performed in the same configuration for a long time, the wire rope can suffer damage (become untwisted) at the same location, whereby twisting can gather at the rope ends. These causes damage to the wire rope.</p> <p>To settle a twisting condition of the wire rope, change the number of parts of line, change the operating configuration, or re-reeve the wire rope, reversing the ends (at the rope socket and at the winch drum) of the rope.</p>

MEMO

EMERGENCY OPERATIONS

GR-750XL-2_OM2(U)-17E

Action against Emergency

WARNING

Do not travel or operate the crane if the machine is out of order. Traveling or operating a crane with a fault can cause a serious accident. Take an emergency procedure, and then contact your nearest TADANO distributor or dealer for inspection and maintenance.

The items that follow are given here.

- If Failure Occurs during Traveling on a Road
- If Stalled at a Railroad Crossing
- To Interrupt DPF Pregeneration
- If Transmission Cannot Be Operated
- If Engine Speed Does Not Increase
- If the Engine Does Not Stop
- If Overheated
- When Towed
- If an Error Occurs in the Load Moment indicator System
- If the Boom Telescoping is Not Possible
- If the Outrigger Status is Not Detected
- If Getting In/Out of Cab Door is Not Possible

If Failure Occurs during Traveling on a Road

Flash hazard lamps to alert the cars behind, and pull the machine to the safe area.

If Stalled at a Railroad Crossing

Immediately push the emergency button at the crossing.

If you cannot use an emergency button, post a person to alert the coming train, considering its braking distance.

To Interrupt DPF Regeneration

If you have to move the vehicle etc, while DPF manual regeneration is activated, you can interrupt regeneration.

1. Push the "ON" side of the DPF regeneration disable switch.
 - DPF regeneration is interrupted and the DPF regeneration disable lamp lights up.

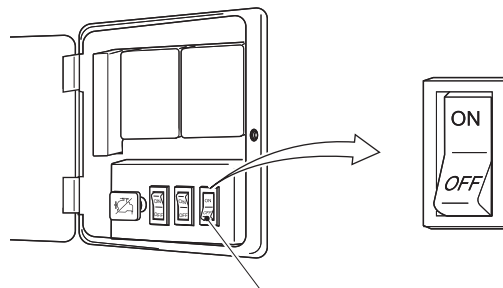

DPF regeneration disable switch

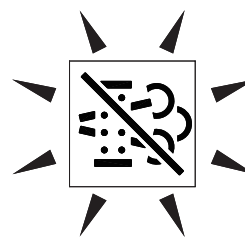

Lights up

K04491-00E

2. Push the "OFF" side of the DPF regeneration disable switch after the cause of the interruption is removed.
 - The DPF regeneration disable lamp goes out and DPF regeneration function is now available.

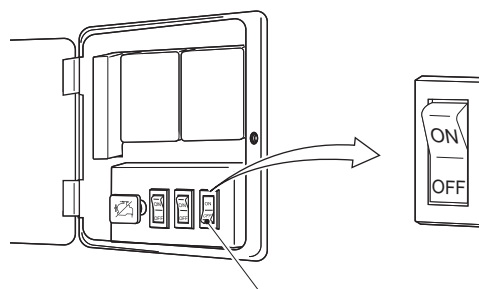

DPF regeneration disable switch



Goes out

K04155-00E

If Transmission Cannot Be Operated

Transmission is controlled electrically by the computer system.

If this system malfunctions, an error number is shown on the error number display as well as the CPU error warning appearing, and transmission operation becomes unavailable.

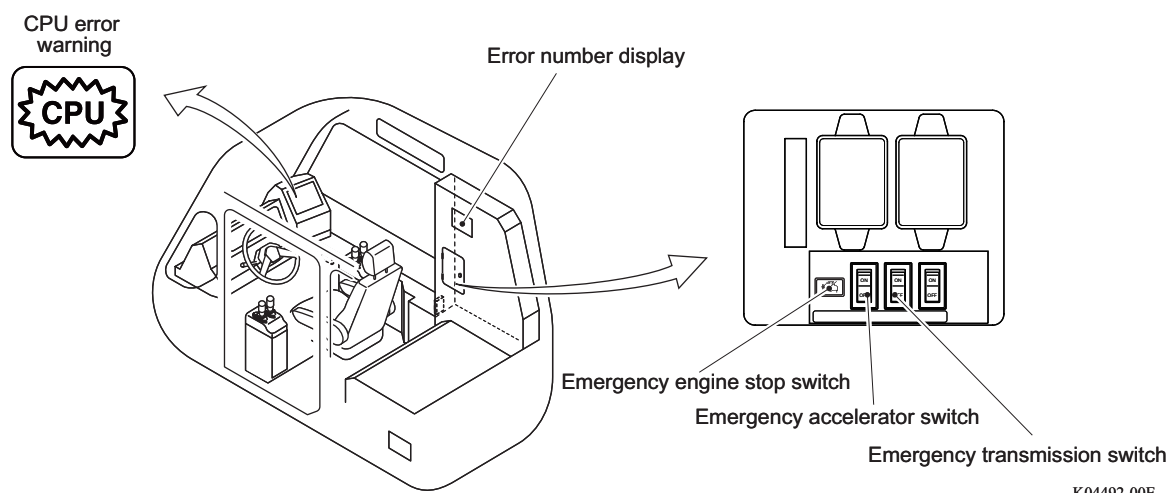

Stop the vehicle at a safe place, or stop crane operation and stow the crane.

Turn the starter switch to "OFF", and wait for 30 seconds or more, and then restart the engine.

After the engine is restarted, check the lighting condition of the CPU error warning, referring to the list below.

Condition of CPU error warning	Remedy
The warning lamp goes out, and does not light up even if the shift lever is operated.	The function of the computer system is recovered, and the normal transmission operation is possible. Even after it is recovered, have the machine inspected by your nearest TADANO distributor or dealer.
The warning lamp goes out, but lights up again when the shift lever is operated.	An abnormality has occurred in the computer system. Contact your nearest TADANO distributor or dealer.
The warning lamp is lit again.	When you move the machine, perform the "Emergency Operation of Transmission" in the next section.

Emergency Operation of Transmission

⚠ WARNING

Use this procedure only for an emergency. The over-shift prevention device will be deactivated, and this can cause damage to the engine. Use the transmission emergency procedure only when you move the vehicle to a safe area in an emergency.

When the emergency transmission switch is set to "ON", the solenoid valves for transmission are switched over without the aid of the computer system.

1. Move the shift lever to "N", and set the parking brake switch to "PARK".
2. Set the emergency transmission switch to "ON".

NOTICE

The torque converter oil temperature gauge, engine coolant temperature gauge, and fuel gauge will not work. This may result in an unexpected accident. Drive the machine carefully.

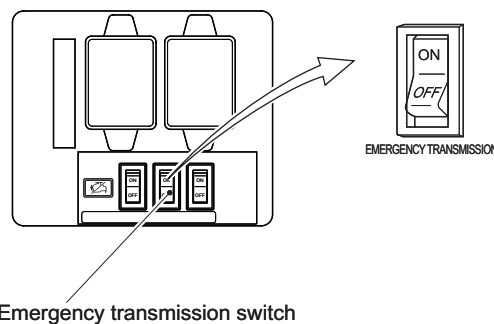

K04493-00E

3. Operate the shift lever and move the vehicle.

NOTICE

Use shift position "1" or "R". Use of other shift positions may result in excessive speed.

4. After you move the vehicle, return the emergency transmission switch to "OFF".

 If you cannot move the vehicle even with the transmission emergency procedure, it may be possible to move the vehicle by forcibly changing over the solenoid valve with the hexagon bolt and lock nut. Before you use this device, contact a TADANO distributor or dealer for instructions on how to use.

For Serial No.548457 or later

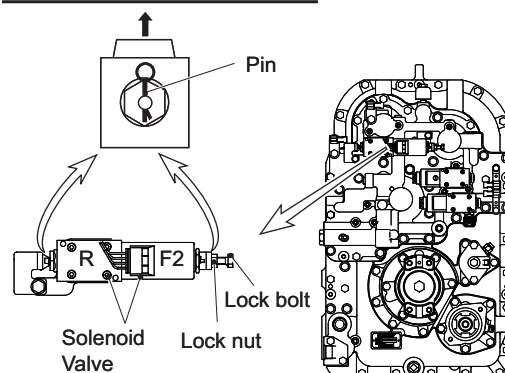

For up to Serial No.548456

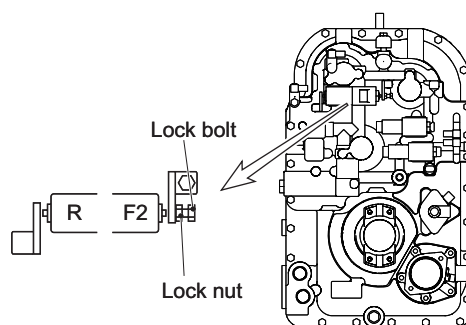

K06335-01E

If Engine Speed Does Not Increase

If the engine speed does not rise to the maximum even when you press the accelerator pedal, use the emergency accelerator switch.

1. Move the shift lever to "N", and set the parking brake switch to "PARK".
2. Set the emergency accelerator switch to "ON".

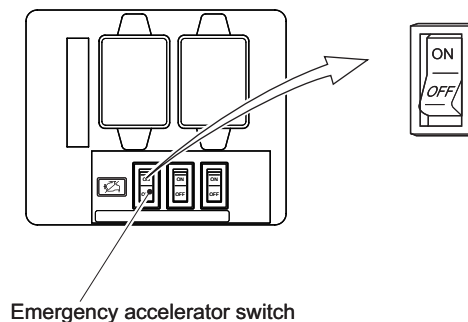

K04494-00E

3. Press the accelerator pedal.

⚠ WARNING

The engine speed rises to the maximum when you press down the accelerator pedal just slightly. Carefully operate the accelerator pedal because the vehicle can suddenly move.

4. Return the emergency accelerator switch to "OFF" after use.

If the Engine Does Not Stop

When the engine does not stop even if the starter switch is set to "OFF", use the emergency engine stop switch.

1. Pull the emergency engine stop switch until the engine stops.
2. After the engine is stopped, return the emergency engine stop switch to the initial position.

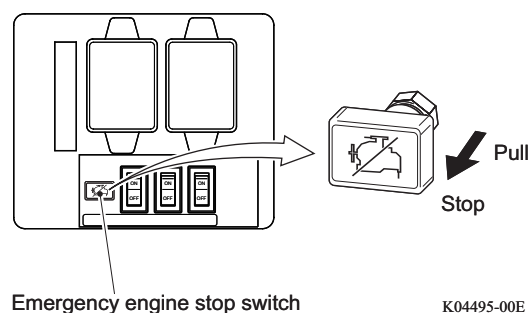

K04495-00E

If Overheated

When the pointer of the water temperature gauge reaches the red zone, the engine is overheated.

Perform the procedure below.

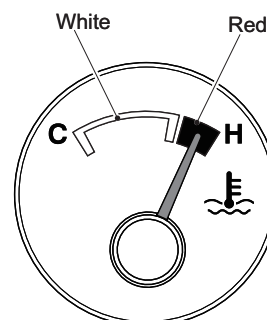

K00500-01E

1. Park the vehicle at a safe area, or stop the crane operation.
2. Keep the engine idling.

NOTICE

**Do not stop the engine immediately.
Otherwise, the water temperature rises sharply, and it can cause seizure.**

3. After the pointer of the water temperature gauge goes near the center of the white zone, stop the engine.

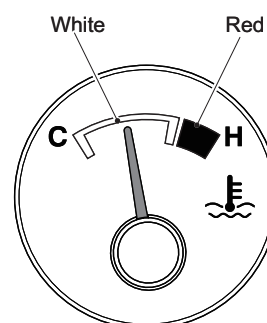

K00501-01E

4. Check the coolant level from the check window. The gauge is normally full with the coolant. If the level is low, add coolant through the supply port.

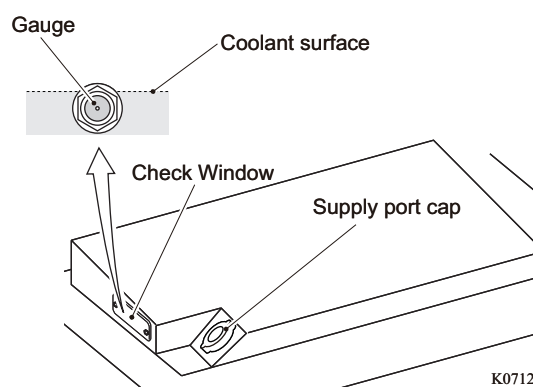

K07121-00E

5. Inspect leakage, damage and looseness of the V-belt, and clogging of the radiator.

When Towed (Vehicle with Emergency Steering Pump)

CAUTION

When the engine is in failure, the steering operation becomes heavy. Drive the vehicle very cautiously. Perform traveling at a low speed with reduced speed change. Do not exceed 6.2 mph (10 km/h) when towed.

When towed, perform the steps below.

1. Open the drain cock on the air tank to decrease the pressure until the exhaust sound is no longer heard.

WARNING

If the plug is removed from the air-supply port while the port is under pressure, the plug may fly off, resulting in an injury. Before removing the plug, open the drain cock on the air tank to release the pressure.

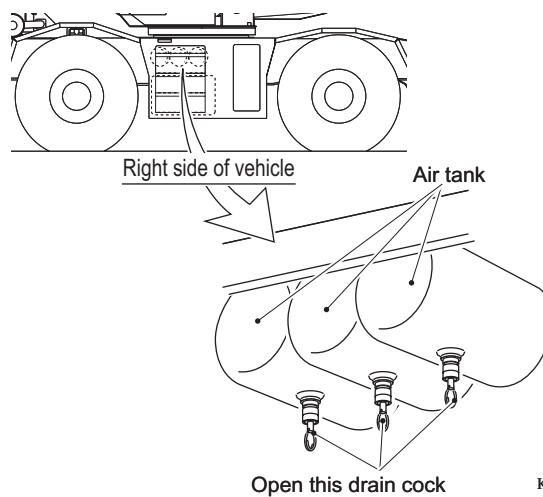

2. Prepare an air hose. Remove the plug on the air-supply port, and connect the air hose from the towing vehicle to the air-supply port.

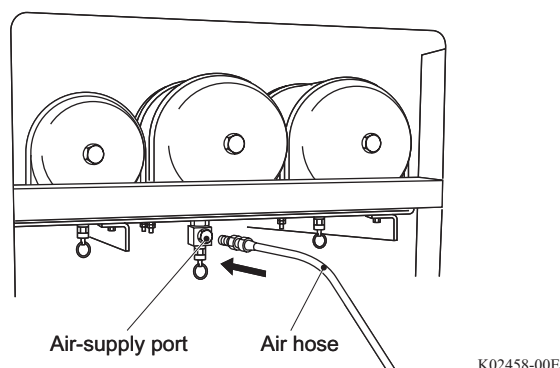

3. Attach a towing cable to the towing hook while sufficient clearance between the towing vehicle and vehicle to be towed is maintained.

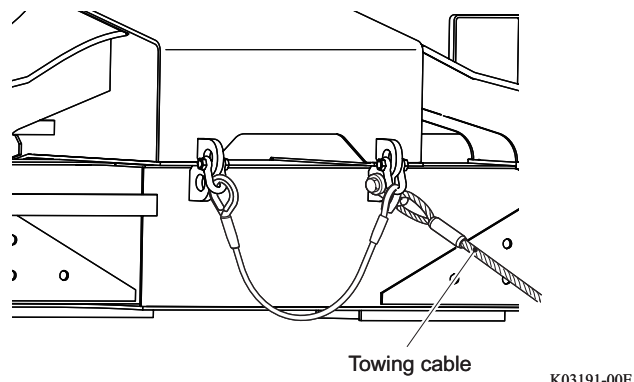

4. Set the switch and lever to the positions as shown below.
Shift lever "N"
Drive mode selector "H/2D"
Starter switch "ON"
5. Check that the pointer of the air pressure gauge exceeds the specified value (red mark).

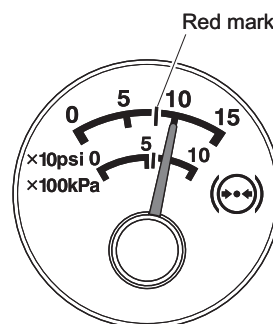

K01342-00E

6. Set the parking brake to "OFF", and start towing of the crane.

If an Error Occurs in the Load Moment Indicator System

⚠ DANGER

When override key switch is turned to "ON" and the PTO switch is turned to "OVERRIDE", load moment indicator automatic stop function is canceled. Never operate the crane in this condition. The crane can overturn or suffer damage, and this can cause a serious accident.

NOTICE

The person having supervisory or management duties of the machine or the job shall keep the key for the override key switch.

When the load moment indicator system is in error, the crane may not operate normally. In this case, stow the crane by the following procedure.

1. When a load is suspended, unwind the winch to lower the load to the ground.
2. Insert the key into the override key switch, and turn it to "ON".

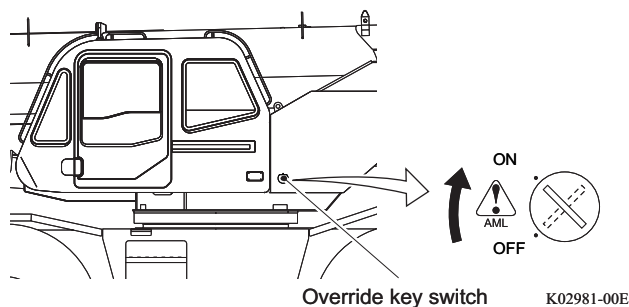

3. Set the PTO switch to "OVERRIDE".
 - The emergency operation warning lamp on the load moment indicator will light up.

 When the switch is released, it will automatically return to "ON".

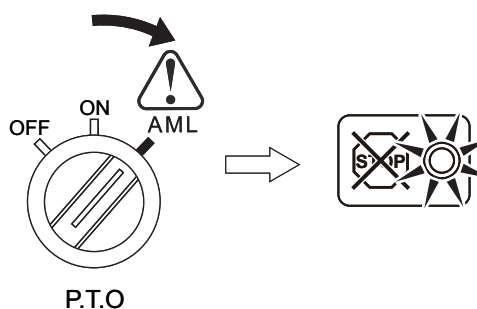

K01340-000

4. Stow the crane.
5. Return the override key switch to "OFF", and remove the key.
6. Set the PTO switch to "OFF".

If the Boom Cannot Be Telescoped

⚠ DANGER

When override key switch is turned to "ON" and the PTO switch is turned to "OVERRIDE", load moment indicator automatic stop function is canceled. Never operate the crane in this condition. The crane may overturn or be damaged, resulting in a serious accident.

NOTICE

The person having supervisory or management duties of the machine or the job shall keep the key for the override key switch.

When the load moment indicator system is in error, the crane may not operate normally. In this case, stow the crane by the following procedure.

1. When a load is suspended, unwind the winch to lower the load to the ground.
2. Insert the key into the override key switch, and turn it to "ON".

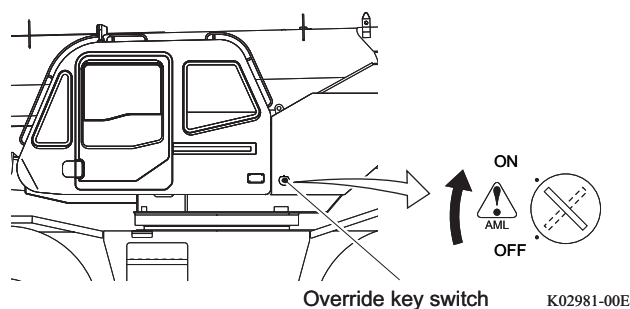

3. Set the PTO switch to "OVERRIDE".
 - The emergency operation warning lamp on the load moment indicator will light up.

 When the switch is released, it will automatically return to "ON".

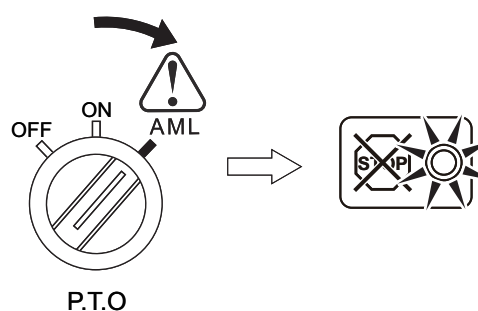

K01340-000

- 4.** While you push the emergency telescoping switch that corresponds to the section you want to telescope, operate the boom telescoping/auxiliary hoist control lever. Pushing the 2nd boom emergency telescoping switch will telescope the 2nd boom section regardless of the state of the 3rd/4th/top boom sections. When you push the 3rd/4th/top boom emergency telescoping switch, the 3rd, 4th, and top boom sections telescope regardless of the state of the 2nd boom section.

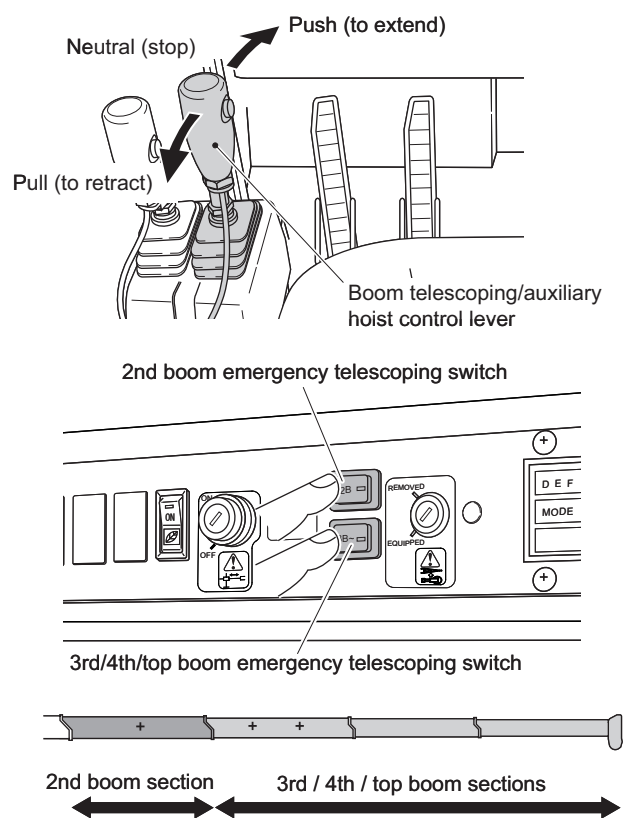

K02982-00E

- 5.** Return the override key switch to "OFF", and remove the key.

If the Outrigger Extension Detection Device Fails

⚠ WARNING

- Do not operate the crane with the emergency outrigger control switch set to "ON". Use this switch only to stow the crane in an emergency.
- After the emergency setting is set, check that the state of outrigger extension and indication on the load moment indicator agree. If you make an wrong setting of the outrigger status, the machine can overturn or suffer damage. This can cause a serious accident.

NOTICE

The person having supervisory or management duties of the machine or the job shall keep the key for the emergency outrigger control switch.

When an error occurs in the outrigger length detector or other devices, the outrigger status is not detected. In this case, register the outrigger status by the procedures that follow.

1. When a load is suspended, unwind the winch to lower the load to the ground.
2. Insert the key into the outrigger status emergency registration switch, and turn it to "ON".
The outrigger status emergency registration icon appears on the display panel.

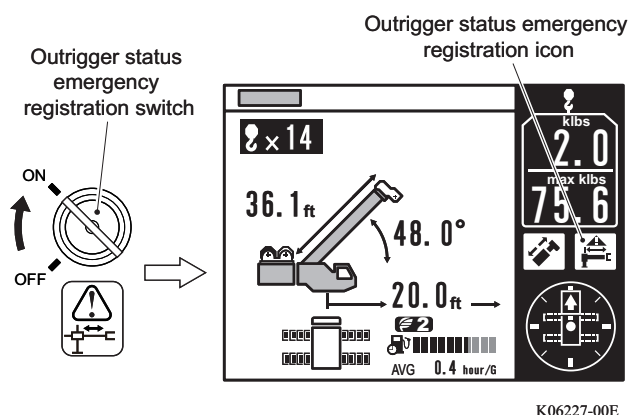

K06227-00E

3. Push the outrigger status select key.
The pop-up window for the outrigger status emergency registration is shown on the display panel.

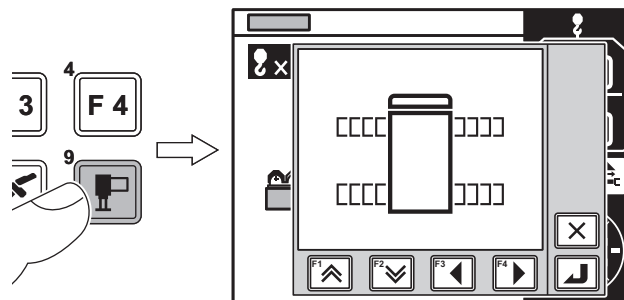

K03069-00E

4. Push the F1 or F2 key to go to the outrigger for which the status is not detected due to the error.

- 5.** Push the outrigger status select key and F3 or F4 key to enter the actual outrigger extension status.

- Outrigger status select key
Determines the outrigger whose status is to be set
- F3 key
Extension status extends (when a left-side outrigger is selected)
Extension status retracts (when a right-side outrigger is selected)
- F4 key
Extension status retracts (when a left-side outrigger is selected)
Extension status extends (when a right-side outrigger is selected)

- 6.** Push the set key to register the setting.

- 7.** Stow the crane.

- 8.** Set the outrigger status emergency registration switch to "OFF", and remove the key.

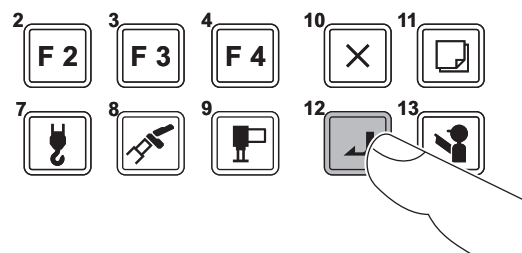

K00678-000

If Getting In/Out of Cab Door is Not Possible (Option)

NOTICE

- The rear window cannot be installed again after it is used as an emergency exit. After it is used as an emergency exit, contact a TADANO distributor or dealer for installing the rear window.
- Usually use the door when entering and exiting the cab.

If the cab door cannot be used as the access or exit, escape out of the cab through the rear window (emergency exit) (option).

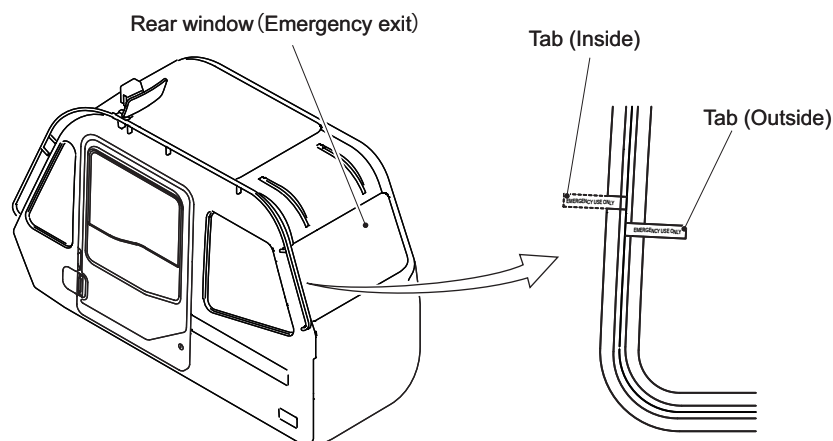

K10426-00E

1. Pull the tab of the rear window slowly along the window frame in the direction of the arrow to strip off the rubber.

 When pulling the tab from inside the cab, pull it up. When pulling the tab from outside the cab, pull it down.

2. Push the rear window to detach it.

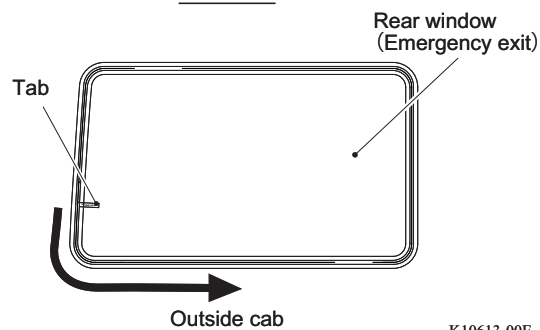
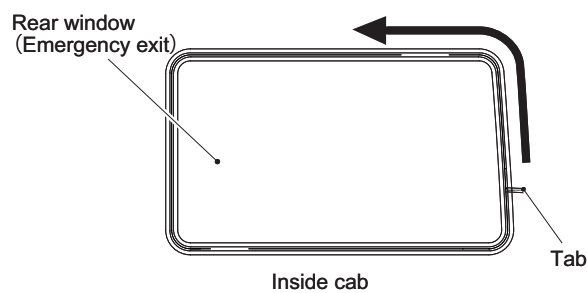

K10613-00E

⚠ WARNING

When detaching the rear window, be careful not to break the window pane. You can suffer an injury.

MEMO

INFORMATION AND DATA

GR-750XL-2_OM2(U)-17E

Conversion Tables

Both the US system (main) and the International System of Units (supplementary) are used, with corresponding values for the latter system given in (). For reference, conversion tables are provided.

Length

millimeter, mm	centimeter, cm	meter, m	inch, in, "	foot, ft, '
1	0.1	0.001	0.03937	0.00328
10	1	0.01	0.3937	0.03281
1000	100	1	39.37	3.281
25.40	2.540	0.0254	1	0.08333
304.8	30.48	0.3048	12	1

mile, mi	kilometer, km
1	1.6093
0.6214	1

Area

square millimeter, mm ²	square centimeter, cm ²	square meter, m ²	square inch, in ²	square foot, ft ²
1	0.01	0.000001	0.00155	
100	1	0.0001	0.155	0.001076
1000000	10000	1	1550	10.764
645.2	6.452	0.000645	1	0.006944
92903.0	929.03	0.09290	144	1

Volume

cubic centimeter, cm ³ , cc	cubic meter, m ³	cubic inch, in ³	cubic foot, ft ³	gallon, gal	cubic inch, in ³	liter, lit, L
1	0.000001	0.0610	0.0000353			
1000000	1	61024	35.31	1	231	3.785
16.39	0.0000164	1	0.000579	0.004329	1	0.01639
28320	0.02832	1728	1	0.2642	61.02	1

Mass

gram, g	kilogram, kg	ounce, oz	pound, lb	metric ton, ton, t	short ton, s. t
1	0.001	0.03527	0.0022		
1000	1	35.27	2.205	0.001	0.001102
28.349	0.02835	1	0.0625	0.00002835	0.00003125
453.592	0.4536	16	1	0.0004536	0.0005
1000000	1000	35274	2205	1	1.102
907185	907.2	32000	2000	0.9072	1

Pressure

kPa	Pa	bar	kgf/cm ²	lb/in ² , psi
1	1000	0.01	0.010197	0.145
0.001	1	0.00001	0.000010197	0.000145
100	100000	1	1.0197	14.50
98.066	98066	0.9807	1	14.22
6.895	6895	0.06895	0.07031	1

Work, energy

N·m	kgf·cm	kgf·m	foot-pound, ft-lb	inch-pound, in-lb
1	10.1972	0.10197	0.7376	8.8522
0.0981	1	0.01	0.0723	0.8681
9.8066	100	1	7.233	86.81
1.3553	13.83	0.1383	1	12
0.1130	1.1525	0.01153	0.08333	1

Centigrade-Fahrenheit

°F	°C	°F	°C	°F	°C	°F	°C
-450	-267.78	-200	-128.89	5	-15.00	30	-1.11
-400	-240.00	-150	-101.11	10	-12.22	35	1.67
-350	-212.22	-100	-73.33	15	-9.44	40	4.44
-300	-184.44	-50	-45.56	20	-6.67	45	7.22
-250	-156.67	0	-17.78	25	-3.89	50	10.00



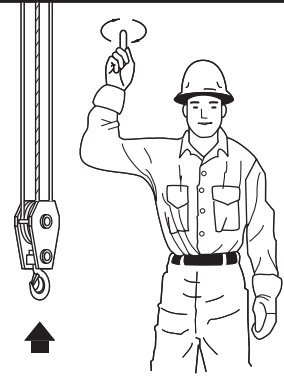
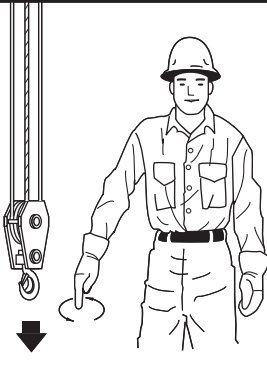
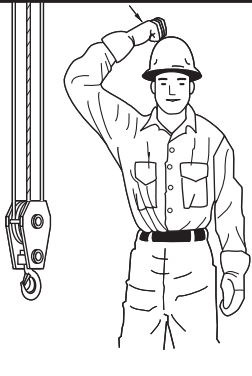
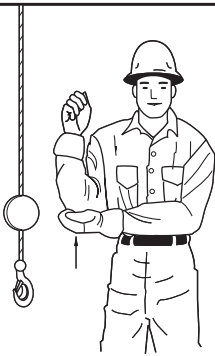
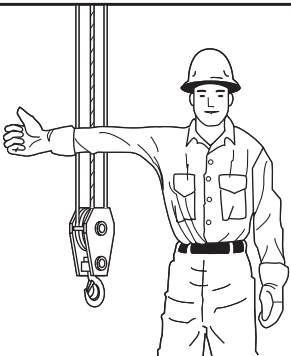
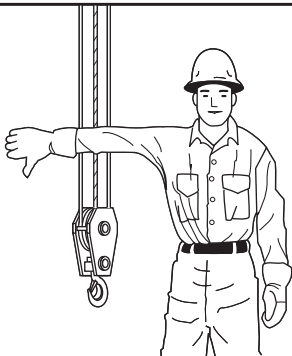
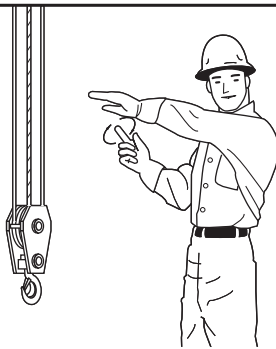
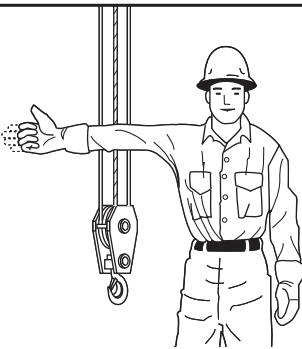
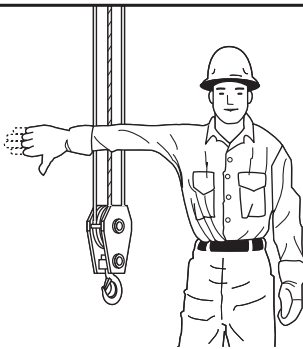

°F	°C	°F	°C	°F	°C	°F	°C
55	12.78	80	26.67	150	65.56	400	204.44
60	15.56	85	29.44	200	93.33	450	232.22
65	18.33	90	32.22	250	121.11	500	260.00
70	21.11	95	35.00	300	148.89	550	287.78
75	23.89	100	37.78	350	176.67	600	315.56

Hand Signals

Hand signals shown are an excerpt from ASME B30. -5-1994..

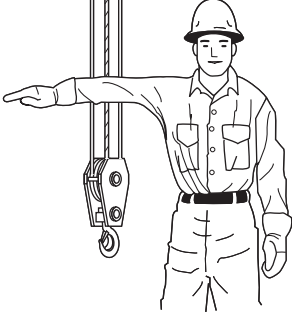
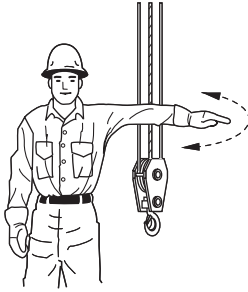
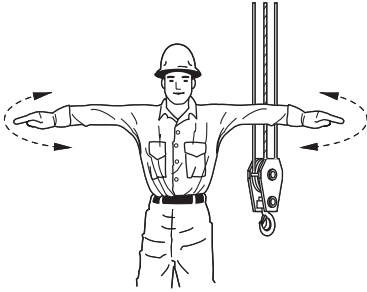
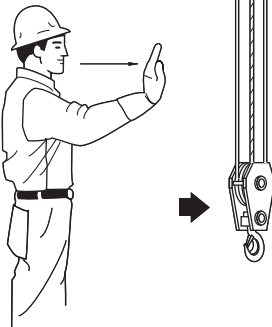
 <p>HOIST. With forearm vertical, forefinger pointing up, move hand in small horizontal circle.</p>	 <p>LOWER. With arm extended downward, forefinger pointing down, move hand in small horizontal circle.</p>	 <p>USE MAIN HOIST. Tap fist on head; then use regular signals.</p>
 <p>USE WHIPLINE (Auxiliary Hoist). Tap elbow with one hand; then use regular signals.</p>	 <p>RAISE BOOM. Arm extended, fingers closed, thumb pointing upward.</p>	 <p>LOWER BOOM. Arm extended, fingers closed, thumb pointing downward.</p>
 <p>MOVE SLOWLY. Use one hand to give any motion signal and place other hand motionless in front of hand giving the motion signal. (Hoist slowly shown as example.)</p>	 <p>RAISE THE BOOM AND LOWER THE LOAD. With arm extended, thumb pointing up, flex fingers in and out as long as load movement is desired.</p>	 <p>LOWER THE BOOM AND RAISE THE LOAD. With arm extended, thumb pointing down, flex fingers in and out as long as load movement is desired.</p>

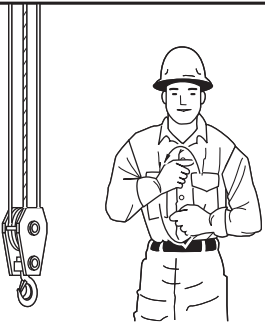
K01343-01E

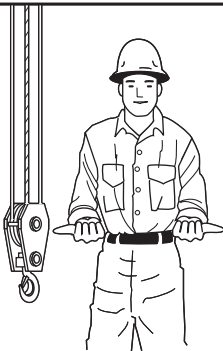
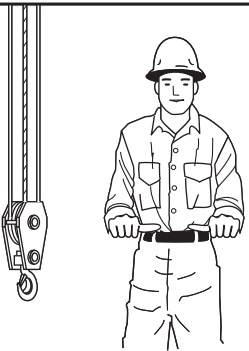
 <p>SWING. Arm extended, point with finger in direction of boom.</p>	 <p>STOP. Arm extended, palm down, move arm back and forth horizontally.</p>	 <p>EMERGENCY STOP. Both arms extended, palms down, move arms back and forth horizontally.</p>
 <p>TRAVEL. Arm extended forward, hand open and slightly raised, make pushing motion in direction of travel.</p>	 <p>DOG EVERYTHING. Clasp hands in front of body.</p>	 <p>TRAVEL(Both Tracks). Use both fists in front of body, making a circular motion about each other, indicating direction of travel, forward or backward. (For land cranes only.)</p>
 <p>TRAVEL(One Track). Lock the track on side indicated by raised fist. Travel opposite track in direction indicated by circular motion of other fist, rotated vertically in front of body. (For land cranes only.)</p>	 <p>EXTEND BOOM(Telescoping Booms). Both fists in front of body with thumbs pointing outward.</p>	 <p>RETRACT BOOM(telescoping Booms). Both fists in front of body with thumbs pointing toward each other.</p>

K01344-01E

GR-750XL-2_OM2(U)-17E

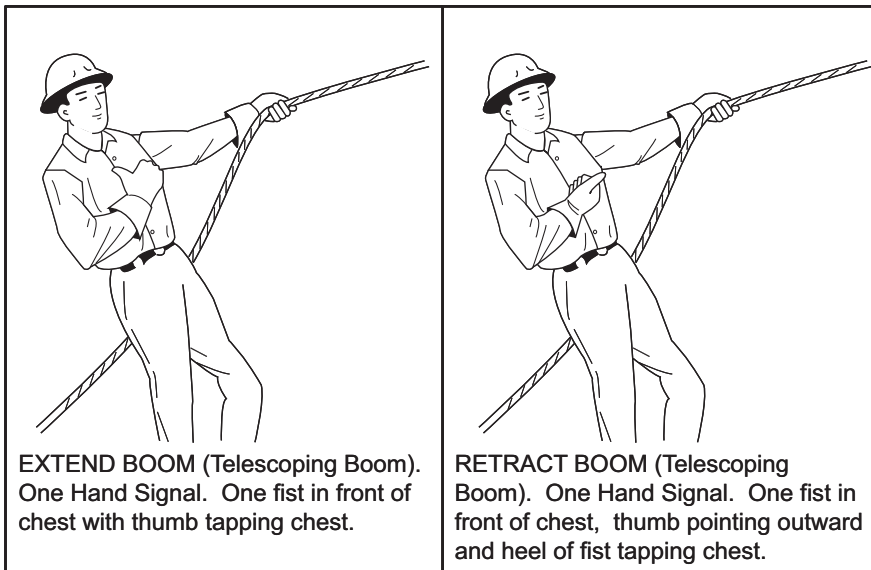

K01345-00E

Major Specifications

Crane Specifications

Maximum Rated Lifting Capacity

Lift state	Maximum rated lifting capacity	Load radius langle	Standard number of part line
36.1 ft (11 m) boom	150,000 lb (68,040 kg)	8 ft (2.44 m)	14
49.2 ft (15 m) boom	90,000 lb (40,820 kg)	8 ft (2.44 m)	8
62.3 ft (19 m) boom	70,500 lb (32,000 kg)	10 ft (3.05 m)	Telescoping mode I : 6
			Telescoping mode II : 4
75.5 ft (23 m) boom	44,100 lb (20,000 kg)	12 ft (3.66 m)	4
88.6 ft (27 m) boom	44,100 lb (20,000 kg)	15 ft (4.57 m)	4
101.7 ft (31 m) boom	36,600 lb (16,590 kg)	20 ft (6.10 m)	4
114.8 ft (35 m) boom	28,500 lb (12,920 kg)	25 ft (7.62 m)	4
128 ft (39 m) boom	22,000 lb (10,000 kg)	25 ft (7.62 m)	4
141.1 ft (43 m) boom	19,800 lb (9,000 kg)	30 ft (9.14 m)	4
33.2 ft (10.1 m) jib	12,300 lb (5,580 kg)	80°	1
58.1 ft (17.7 m) jib	7,100 lb (3,200 kg)	80°	1
Single top	12,300 lb (5,580 kg)	-----	1

Lifting Height, Length, Angle, and Speed

Item		Data
Maximum lifting height	Boom	142.4 ft (43.4 m)
	Jib	198.9 ft (60.5 m)
Maximum load radius	Boom	132.5 ft (40.4 m)
	Jib	165 ft (50.3 m)
Boom length		36.1 to 141.1 ft (11.0 to 43.0 m)
Boom extension speed		105 ft / 128 s (m / 128 s)
Jib length		33.2 ft, 58.1 ft (10.1 m, 17.7 m)
Hoist-up speed	Main winch	446 ft/min (136 m/min) (4th layer)
	Auxiliary winch	446 ft/min (136 m/min) (4th layer)
Boom angle		-1.6° to 80.3°
Boom raising speed		20° to 60°/ 46 s
Swing angle		360° continuous
Swing speed		2.4 min ⁻¹ {rpm}

Hoisting Performance

Line Speeds and Pulls

Layer	Main or Auxiliary hoist - 15-3/4" (0.4 m) drum			
	Line speeds (*1)		Line pulls Available (*2)	
	F. P. M	m/min	Lbs	kgf
1st	358	109	15,200	6,880
2nd	387	118	13,900	6,310
3rd	417	127	12,800	5,820
4th	446	136	11,900	5,410
5th	475	144	11,100	5,050
6th	504	153	10,400	4,730
7th (*3)	533	162	9,800	4,460

(*1): Line speeds based only on hook block, not loaded.

(*2): Developed by machinery with each layer of wire rope, but not based on rope strength or other limitation in machinery or equipment.

(*3): Seventh layer of wire rope are not recommended for hoisting operations.

Drum Wire Rope Capacities

Wire rope Layer	Main and auxiliary drum grooved lagging 3/4" (19mm) wire rope			
	Rope per layer		Total wire rope	
	Feet	Meters	Feet	Meters
1st	123.3	37.6	123.3	37.6
2nd	133.5	40.7	256.8	78.3
3rd	143.3	43.7	400.2	122.0
4th	153.5	46.8	553.8	168.8
5th	163.3	49.8	717.1	218.6
6th	173.3	53.0	891.0	271.6
7th	183.3	55.9	1,074.4	327.5

Drum Dimensions

	Inch	mm
Root diameter	15-3/4"	400
Length	23-9/16"	599
Flange diameter	27-3/8"	695

Carrier Specifications

Item	Data
Engine	Cummins QSB 6.7 [Tier 4i]
Displacement	409 in ³ (6.7 L)
Maximum speed	22.0 mph (36 km/h)

Overall Dimensions

No.	
1. Float size	1' 11-5/8" (ϕ 600 mm)
2.	11' 1-5/8" (3,395 mm)
3.	12' 10-7/8" (3,935 mm)
4. Outrigger maximum extension width	23' 11-3/8" (7,300 mm)
5. Tail swing radius	13' 9" (4,190 mm)
6.	11' 10-3/4" (3,625 mm)
7.	12' 1-7/8" (3,705 mm)
8. Overall width	10' 10-1/2" (3,315 mm)
9. Rear overhang	7' 10-5/8" (2,405 mm)
10. Wheelbase	12' 11-1/2" (3,950 mm)
11.	6' 8-1/8" (2,035 mm)
12. Front overhang	23' 5/8" (7,025 mm)
13. Overall length	43' 10-3/4" (13,380 mm)
14. Overall height	12' 5-1/4" (3,790 mm)

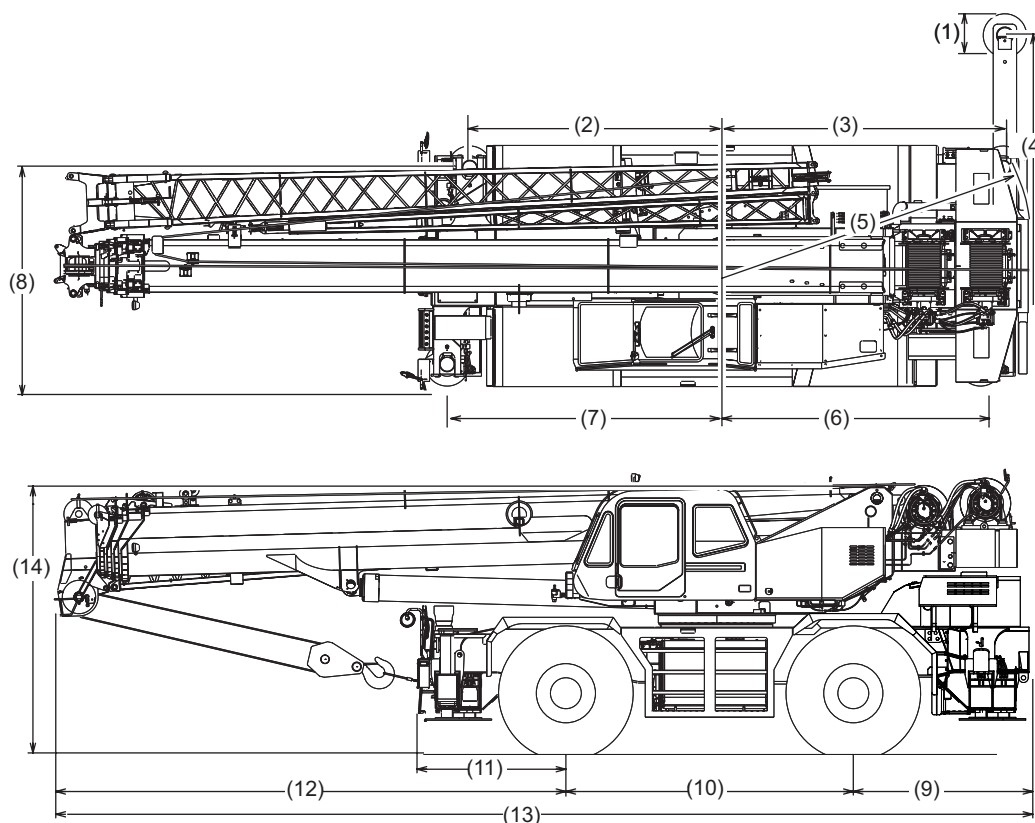

K07057-00E

Mass

Axle Weight Distribution Chart

		Unit (Pounds)			Unit (Kilograms)		
		GVW	Front	Rear	GVW	Front	Rear
Base machine		97,620	49,650	47,970	44,280	22,520	21,760
Remove:							
0	6.2 short tons (5.6 metric tons) hook ball	-330	-470	140	-150	-213	64
1	75 short tons (68 metric tons) hook block	-1,300	-2,310	1,010	-590	-1,048	458
2	Top jib	-740	-805	65	-336	-364	29
3	Base jib	-1,910	-3,270	1,360	-867	-1,483	616
4	Auxiliary lifting sheave	-110	-300	190	-50	-137	87
5	Removable Counterweight (with Auxiliary Hoist & wire rope)	-12,500	5,510	-18,010	-5,670	2,498	-8,168

Wire Rope

Specifications

Main winch	Posture	IWRC 6×WS (31) O/O
	Allowable load	12,300 lbs (5,600 kg)
	Ultimate (failure) load	54,700 lbs (24,800 kg)
	Diameter	3/4 in (19 mm)
	Length	771 ft (235 m)
	Mass	1.18 lbs/ft (1.76 kg/m)
Auxiliary winch	Posture	IWRC 6×WS (31) O/O
	Allowable load	12,300 lbs (5,600 kg)
	Ultimate (failure) load	54,700 lbs (24,800 kg)
	Diameter	3/4 in (19 mm)
	Length	436.37 ft (133 m)
	Mass	1.18 lbs/ ft (1.76 kg/m)

Other

Item	Weight
Maximum vertical load capacity of outrigger	116,200 lbs (52,700 kg)

Oils and Greases

Oils and Greases Table

The oils and greases listed below are used in new cranes at the time of shipment from the factory.

Oil/Grease	No.	Component	Brand (manufacturer)	Capacity/quantity	
Grease	Upper Structure	1	Side and lower surfaces of boom (Sliding sections of boom)	TNR (TADANO Genuine)	As required
		2	Slide plate (upper surface of boom)		
		3	Wire rope (for main winch)	Mobilarma 798 (Exxon Mobil)	
		4	Wire rope (for auxiliary winch)		
		5	Wire rope (for boom telescoping)		
		6	Swing bearing	Daphne Eponex SR No. 2 (Idemitsu)	
		7	Swing gear		
		8	Jib connecting pin boss		
		9	Jib end sheave pin		
		10	Boom elevating cylinder lower pivot pin		
		11	Boom bottom pivot pin		
		12	Main hook block (option)		
		13	Auxiliary hook block (option)		
	Lower Structure	21	Outrigger float	Molybdenum Grease No. 2 (Cosmo)	
		22	Propeller shaft	Daphne Eponex SR No. 2 (Idemitsu)	
		23	Suspension lock cylinder	Molybdenum Grease No. 2 (Cosmo)	
		24	King pin	Daphne Eponex SR No. 2 (Idemitsu)	
25		Steering cylinder	Molybdenum Grease No. 2 (Cosmo)		
26		Tie rod end	Daphne Eponex SR No. 2 (Idemitsu)		
Gear Oil	1	Winch speed reducer	Mobilgear 600 XP150 (Exxon Mobil)	1.59 gal (6 L) × 2	
	2	Swing speed reducer	Mobilgear 600 XP320 (Exxon Mobil)	1 gal (3.8 L)	
	3	Axle (Carrier)	Apolloil Gear HE-90S (Idemitsu) or Cosmo Gear GL-5 90 (Cosmo) or	7 gal (26.5 L) × 2	
	4	Axle (Planetary Gear)	Gear oil 75W-90 GL-5 (JX Nippon oil & energy)	1.32 gal (5 L) × 4	
Engine Oil	1	Engine	API service classification: SAE15W-40, class CJ or better (SAE10W-30 for cold climates)	4.12 gal (15.0 L)	
Long-life coolant	1	Radiator	TADANO Genuine Long-life Coolant	7.4 gal (28 L) (*1) 3.7 gal (14 L) (*2) (at 50: 50 water: coolant ratio)	
Torque Converter Oil	1	Torque converter	TADANO Genuine Torque Converter Oil	9.2 gal (35.0 L) (*3)	
Fuel	1	Fuel tank	ASTM/D-975 2 Grade 2-D	79.3 gal (300 L)	
Brake fluid	1	Brake fluid reservoir	TADANO Genuine Brake Fluid DOT-5.1	0.45 gal (1.7 L)	
Hydraulic Oil	1	Hydraulic oil tank	TADANO Hydraulic Oil LL (TADANO Genuine) or Daphne Super Hydro 22X (Idemitsu)	Approx. 221 gal (837 L) (*4) Approx. 288 gal (1,090 L) (*3)	

(*1): Total capacity (*2): Required amount of long-life coolant (*3): Total oil capacity (*4): Tank capacity

Recommended Oils and Greases

Use the oils and greases used at the time of factory shipment for replacement. If you must use different brands of oils and greases, use the brands shown in the equivalent field in the table below.

Grease

Component	Oil/grease used at shipment		Equivalent	
	Manufacturer	Brand	Manufacturer	Brand
Boom	TADANO Genuine	TNR	-----	-----
Wire Rope	Exxon Mobil	Mobilarma 798	-----	-----
King pin, tie rod end	Cosmo	Molybdenum Grease No. 2	Shell	Shell Sunlight Grease MB2
			Idemitsu	Daphne Grease M No.2
			JX Nippon oil & energy	Molynoc grease AP2
Others	Idemitsu	Daphne Eponex SR No. 2	Exxon Mobil	Mobilux EP2
			Shell	Shell alvania EP grease 2
			JX Nippon oil & energy	Epnoc grease AP(N) 2
			Cosmo	Cosmo grease dynamax EP No.2

Gear Oil

Component	Oil/grease used at shipment			Equivalent	
	Manufacturer	Brand	Class	Manufacturer	Brand
Winch speed reducer (main/auxiliary winch)	Exxon Mobil	Mobilgear 600 XP150	ISO VG 150	Shell	Shell Omala Oil 150
				Idemitsu	Daphne Super Gear Oil 150
				JX Nippon oil & energy	Bonnoc M150
				Cosmo	Cosmo Gear SE150
Swing speed reducer	Exxon Mobil	Mobilgear 600 XP320	ISO VG 320	Shell	Shell Omala Oil 320
				Idemitsu	Daphne Super Gear Oil 320
				JX Nippon oil & energy	Bonnoc M320
				Cosmo	Cosmo Gear SE320
Axle	Class		Ambient temperature		Grade
	API service classification GL-5		-4°F or over (-20°C or over)		SAE 90
			-40°F to 50°F (-40°C to 10°C)		SAE 75W-90

Engine Oil

Component	Oil/grease used at shipment		Equivalent	
	Class		Manufacturer	Brand
Engine	(Standard) API service classification: Class CJ or better, SAE15W-40		Refer to the separate engine manual.	
	(Cold climates) API service classification: Class CJ or better, SAE10W-30			

LLC (Long-life Coolant)

Component	Oil/grease used at shipment		Equivalent	
	Manufacturer	Brand	Manufacturer	Brand
Engine coolant	TADANO Genuine	TADANO Genuine Long-life Coolant	Exxon Mobil	
			Shell	
			Idemitsu	Apollo radiator coolant
			JX Nippon oil & energy	Super coolant X
			Cosmo	

Torque Converter Oil

Component	Oil/grease used at shipment		Equivalent	
	Manufacturer	Brand	Manufacturer	Brand
Torque converter, transmission	TADANO Genuine	TADANO Genuine Torque Converter Oil	Exxon Mobil	Mobil ATF220
			Shell	Shell gelco ATF
			Idemitsu	Apolloil ATF D-2
			JX Nippon oil & energy	ATF II (N)
			Cosmo	Cosmo ATF2

Brake Fluid

Component	Oil/grease used at shipment		Equivalent	
	Manufacturer	Brand	Manufacturer	Brand
Brake Fluid Reservoir	TADANO Genuine	TADANO Genuine Brake Fluid DOT-5.1	BP	BP Brake Super DOT 4
			Pentosin	Pentosin super DOT 4
			Textar	Textar super DOT 4
			Ate	Ate super DOT 4
			M. Benz	DOT 4 Plus

Hydraulic Oil

Component	Oil/grease used at shipment			Equivalent	
	Manufacturer	Brand	Class	Manufacturer	Brand
Hydraulic Oil Tank	TADANO Genuine	TADANO Hydraulic Oil LL	ISO VG46	Exxon Mobil	Mobil DTE25
				Shell	Shell tellus oil 46
				Idemitsu	Daphne super hydro 46A
				JX Nippon oil & energy	Super hyrando 46
				Cosmo	Cosmo hydro HV46
			ISO VG32	Exxon Mobil	Mobil DTE24
				Shell	Shell tellus oil 32
				Idemitsu	Daphne super hydro 32A
				JX Nippon oil & energy	Super hyrando 32
				Cosmo	Cosmo hydro HV32
	Idemitsu	Daphne Super Hydro 22X	ISO VG22	Exxon Mobil	Mobil DTE22
				Shell	Shell tellus oil 22
				JX Nippon oil & energy	Super hyrando 22
				Cosmo	Cosmo hydro HV22

Service Data

Service Data

Relief Valve Set Pressure

Circuit		Set pressure
Winch	Hoist up	3,980 psi {27.5 MPa}
	Extend	2,990 psi {20.6 MPa}
Telescoping	Retract	2,990 psi {20.6 MPa}
	Raise	2,990 psi {20.6 MPa}
Elevating	Lower	420 psi {2.9 MPa}
	Steering	2,420 psi {16.7 MPa}
Swing		2,990 psi {20.6 MPa}

Air Pressure in Air Tank

Specified pressure	108 to 121 psi {745 to 833 kPa}
--------------------	---------------------------------

Oil Pressure in Torque Converter

Engine revolution	Set pressure
670 min ⁻¹ {rpm}	250 psi {1.7 MPa} or more
MAX	305 to 355 psi {2.1 to 2.45 MPa}

Tire Air Pressure

Tire size	Air pressure	
	Traveling	On-rubber Operation
29.5-25 22PR	50 psi {350 kPa}	60 psi {420 kPa}
29.5-25 28PR	47 psi {330 kPa}	65 psi {450 kPa}

Recommended Tires

29.5-25-22PR	(BRIDGESTONE VL2A E-3A) (TOYO TIRE G62 E-3)
29.5-25-28PR E-3	

Extension Width of Outriggers and Working Area

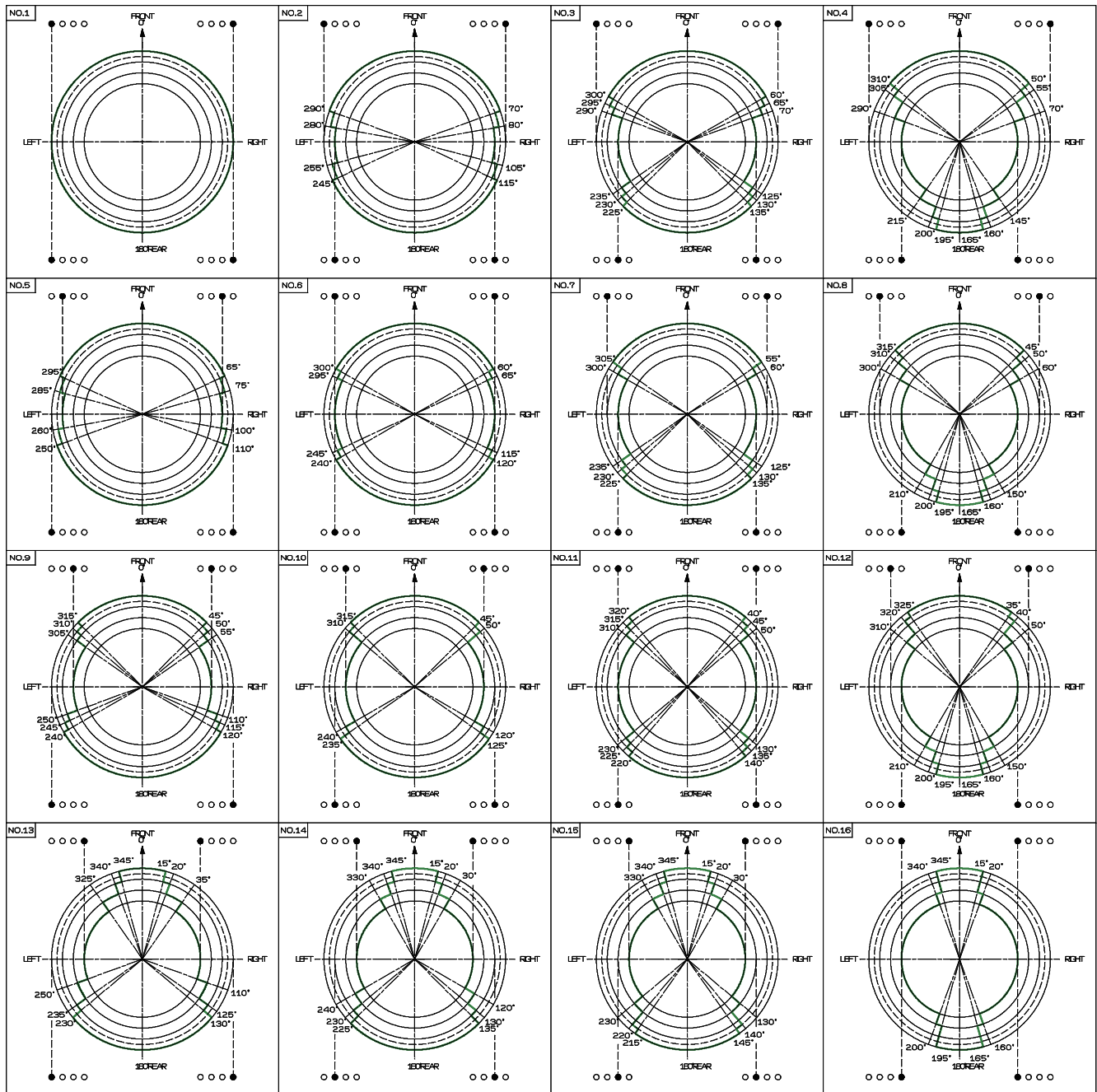

361-953-44051-0

TADANO LTD.

Head Office

Ko-34, Shinden-cho, Takamatsu,
761-0185, Japan

International Operation

Tadano Ryogoku Bldg.
4-12, Kamezawa 2-chome,
Sumida-ku, Tokyo, 130-0014, Japan
Tel.: +81-3-3621-7750
Tel fax: +81-3-3621-7785

TADANO AMERICA CORP.

4242 West Greens RD
Houston, Texas 77066, U. S. A.
Tel.: 1-281-869-0030
Fax: 1-281-869-0040

Revision history	
1	
2	
3	
4	
5	

